

Appendix U15

2016 Freight Gateway Study Update

Appendix U15 Contents

2016 Freight Gateway Study Update

2016 FREIGHT GATEWAY STUDY UPDATE

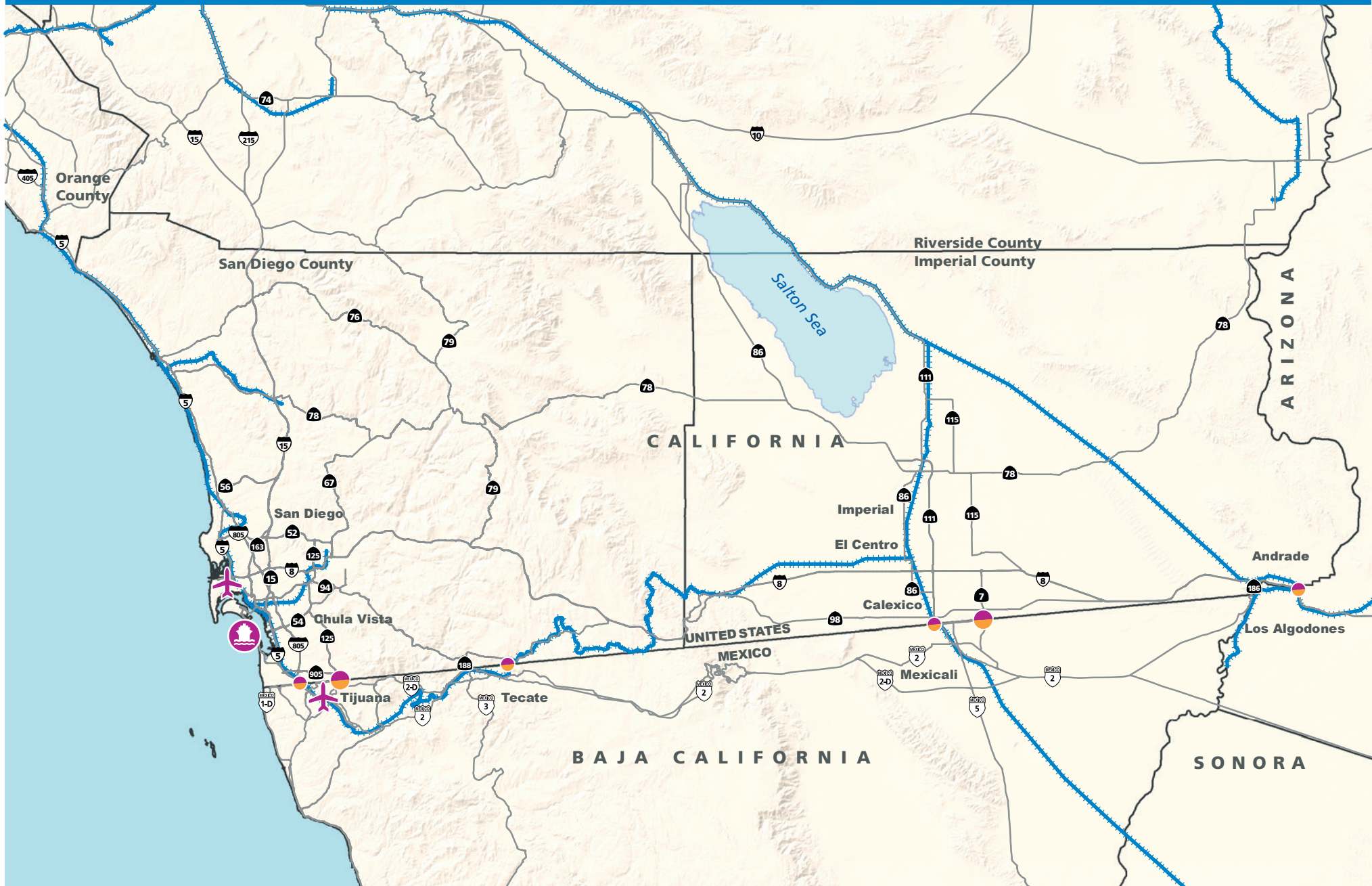

PREFACE 2016 FREIGHT GATEWAY STUDY UPDATE

Intended Uses This Study

The goal of the 2016 Freight Gateway Study Update is to give SANDAG and other stakeholders' access to thorough freight forecast information as an estimation tool to better plan and manage a sustainable freight network. The 2016 Freight Gateway Study Update is primarily intended to inform the Goods Movement Strategy section of the 2050 Regional Transportation Plan by identifying current (2012 baseline) and future freight volumes out to 2050. Additionally, the Gateway Study will provide insights into how freight investments could impact goods movement, industrial development, and freight related economic activity in our region.

Forecasting Caveats

This forecast, just as any other forecasting tool, should be used as but one planning tool; a tool that should be used in conjunction with other real time information, comparisons with industry news, and regular re-calibration based upon changing economic conditions. Forecasting freight flows out to 2050 is *de facto* understood to be a static snapshot, and subject to many and varied unforeseeable policy and or market influences. Notwithstanding these caveats, the study team developed this 2016 Freight Gateway Study Update forecast by analyzing the most comprehensive data sets publicly available and synthesizing that complex information into an executive briefing format.

Forecast Consistency with National Projections

For the most comprehensive publicly available coverage of freight activity, the U.S. Department of Transportation's (U.S. DOT) multimodal Freight Analysis Framework (FAF) has been used as the default source of historic data in the Freight Gateway Study Update Project. The FAF is published by the U.S. DOT and Federal Highway Administration (FHWA). This annual data covers multimodal freight flows, domestic and international, of the United States, with commodity and origin and destination region detail. This is the most comprehensive and frequently-used public freight flow data source used in public sector planning around the country. The current version is referred to by the FHWA as FAF 4. Every five years, the FHWA releases annual updates.

This page intentionally left blank.

TABLE OF CONTENTS

1 EXECUTIVE SUMMARY AND INTRODUCTION TO FREIGHT DYNAMICS IN THE GATEWAY REGION

1.1	Understanding Freight Movement	1.1
1.2	The Role of Freight Movement in the National and Regional Economy	1.2
1.3	Characteristics of and the Challenges to the Regional Freight Network.....	1.7
1.4	Policies and Potential Impacts of Sustainable Goods Movement in the Region	1.12
1.5	Study Objectives and Plan of this Report	1.16
1.6	Gateway Tables: Summary Snapshots of Regional Freight	1.16

2 REGIONAL FREIGHT INFRASTRUCTURE PROFILE

2.1	San Diego County Freight Infrastructure.....	2.1
2.1.1	Road Network and Ports of Entry	2.1
2.1.1.1	Land Ports of Entry.....	2.1
2.1.1.2	Roadway Network.....	2.2
2.1.1.3	Gaps in Existing Road Infrastructure.....	2.4
2.1.2	Rail Infrastructure.....	2.4
2.1.2.1	Existing Rail Lines and Ports of Entry	2.5
2.1.2.2	Gaps in Existing Rail Infrastructure	2.9
2.1.3	Seaport Infrastructure.....	2.10
2.1.3.1	Existing Seaport Infrastructure.....	2.10
2.1.3.2	Gaps in Existing Seaport Infrastructure	2.14
2.1.4	Airport Infrastructure.....	2.14
2.1.4.1	Existing Airport Infrastructure	2.14
2.1.4.2	Gaps in Existing Airport Infrastructure	2.16
2.1.5	Warehousing Infrastructure	2.16
2.1.6	Pipeline System.....	2.18
2.2	Imperial County Freight Infrastructure.....	2.20
2.2.1	Road Network and Ports of Entry	2.20
2.2.2	Calexico West/Mexicali I POE.....	2.21
2.2.3	Calexico East/Mexicali II POE.....	2.21

2 REGIONAL FREIGHT INFRASTRUCTURE PROFILE (Cont'd)

2.2.3.1 Roadway Network..... 2.22

2.2.4 Rail Infrastructure..... 2.24

2.2.5 Seaport Infrastructure 2.25

2.2.6 Airport Infrastructure..... 2.25

2.2.7 Warehousing Infrastructure 2.25

2.2.8 Pipeline Infrastructure 2.27

2.3 Baja California Freight Infrastructure 2.30

2.3.1 Road Network..... 2.30

2.3.2 Rail Infrastructure..... 2.31

2.3.3 Seaport Infrastructure 2.32

2.3.4 Airport Infrastructure..... 2.33

2.3.5 Warehousing Infrastructure 2.34

3 GATEWAY REGION: UNDERSTANDING THE IMPORTANCE OF TRUCK CORRIDORS

3.1 Updated Gateway Region Corridor Freight Flow Analysis: Approach 3.1

3.2 Updated Key Truck Corridor Flow Analysis 3.2

3.3 Domestic Freight: Corridor Discussion by Tonnage 3.8

3.4 International Freight: Corridor Discussion by Tonnage..... 3.20

3.5 Truck International and Domestic Freight: 2050 Gateway Forecast..... 3.29

3.6 International Freight: Key Commodities at the Port of San Diego by Tonnage..... 3.38

3.7 Air Cargo Freight: Domestic, International, and Mail Cargo at the San Diego International Airport..... 3.39

3.8 Gateway Supply Chain Example Vignettes..... 3.40

4 POLICY CONSTRAINTS, MARKET CONDITIONS, AND REGULATORY ISSUES

4.1 Freight Policy Issues..... 4.2

4.1.1 Funding Availability and Funding Priorities..... 4.2

4.2 Market Issues Impacting Freight 4.4

4.2.1 Changing Market Conditions and Supply Chain Drivers 4.4

4.3 Regulatory Issues Impacting Freight 4.5

4.3.1 National: U.S. DOT Mexican Trucking Regulations..... 4.5

4.3.2 State: California Air Resources Board Regulations 4.6

4 POLICY CONSTRAINTS, MARKET CONDITIONS, AND REGULATORY ISSUES (Cont'd)

4.3.3 State: California Sustainable Community Strategies Planning Requirements 4.8

4.3.4 Local: Land Use Conflicts and Land Use Availability for Freight..... 4.9

4.4 International Developments Impacting Freight..... 4.9

4.4.1 Expansion of Panama Canal 4.10

4.4.2 Intermodal Rail Service Growth 4.11

4.4.3 Port Developments in Baja California 4.11

4.4.4 Port of San Diego Issues..... 4.13

TABLE OF FIGURES

1 EXECUTIVE SUMMARY AND INTRODUCTION TO FREIGHT DYNAMICS IN THE GATEWAY REGION

Figure 1.1	Freight Transportation and Economic Growth.....	1.3
Figure 1.2	U.S. Gross Domestic Product and Trade (2002-2013)	1.4
Figure 1.3	Percentage Change in the World Trade and Output.....	1.5
Figure 1.4	Trade Growth and Economic Growth by Metropolitan Area.....	1.6
Figure 1.5	San Diego Trade and Economic Growth Are Correlated	1.8
Figure 1.6	Large San Diego – Mexico Trade is Dominated by U.S. Imports	1.9
Figure 1.7	Annual U.S. Imports and Exports Since the North American Free Trade Agreement	1.10
Figure 1.8	Integration of U.S. Trade with Mexico and Other Trade Partners.....	1.11
Figure 1.9	San Diego Region Urban Development Vision.....	1.12
Figure 1.10	Los Angeles Basin/San Diego Truck Distribution Interdependency	1.15
Figure 1.11	Summary of Freight Flows through the Regions Gateways in Volume: 2050 Forecast	1.17
Figure 1.12	Summary of Freight Flows through the Regions Gateways in Value: 2050 Forecast	1.18
Figure 1.13	Summary of Freight Flows through the Gateways by Modal Volume: 2050 Forecast	1.19
Figure 1.14	Summary of Freight Flows through the Gateways by Modal Value: 2050 Forecast	1.20
Figure 1.15	Summary of Freight Flows through the Regions International Gateways and Comparison to Domestic Truck Circulation: 2050 Forecast	1.21

2 REGIONAL FREIGHT INFRASTRUCTURE PROFILE

Figure 2.1	Major Truck Routes in the Gateway Region.....	2.3
Figure 2.2	Rail Lines in the Gateway Region.....	2.6
Figure 2.3	Gateway Region Rail Line Owners Map.....	2.7
Figure 2.4	Gateway Region Rail Line Operators Map.....	2.8
Figure 2.5	Tenth Avenue Marine Terminal.....	2.11
Figure 2.6	National City Marine Terminal	2.12

2 REGIONAL FREIGHT INFRASTRUCTURE PROFILE (Cont'd)

Figure 2.7	Transportation Network Serving Tenth Avenue Marine Terminal and National City Marine Terminal	2.13
Figure 2.8	San Diego International Airport, Lindbergh Field	2.15
Figure 2.9	Warehousing Facilities in the Otay Mesa Border Crossing Area	2.18
Figure 2.10	Pipeline System in Southern California	2.19
Figure 2.11	Pipeline System in San Diego County	2.20
Figure 2.12	Major Truck Routes in Imperial County	2.24
Figure 2.13	Calexico Warehousing District	2.26
Figure 2.14	Calexico East Warehousing District	2.27
Figure 2.15	Pipeline System in Southern California	2.28
Figure 2.16	Pipeline System in Imperial County	2.29
Figure 2.17	Major Roads in Baja California	2.30
Figure 2.18	Tijuana – Tecate Short Line	2.31
Figure 2.19	Container Ship at Puerto de Ensenada	2.32
Figure 2.20	Tijuana International Airport	2.33

3 GATEWAY REGION: UNDERSTANDING THE IMPORTANCE OF TRUCK CORRIDORS

Figure 3.1	Commercial and Industrial Land Uses in San Diego County	3.3
Figure 3.2	Commercial and Industrial Land Uses in Imperial County	3.4
Figure 3.3	Freight Gateway Flows in the San Diego/Imperial County Region	3.5
Figure 3.4	Truck Gateway Flows (in tons) in the San Diego/Imperial County Region	3.6
Figure 3.5	Aircraft and Marine Cargo Gateway Flows (in tons) in the San Diego County Region	3.7
Figure 3.6	Truck Tons Percentage by Origin/Destination of Movement, San Diego	3.8
Figure 3.7	Truck Tons Percentage by Direction, San Diego	3.9
Figure 3.8	Inbound Domestic Freight Percentage by Mode of Transportation	3.11
Figure 3.9	Outbound Domestic Freight Percentage by Mode of Transportation	3.12
Figure 3.10	Inbound Domestic Freight Tons by Truck by Commodity to San Diego	3.13
Figure 3.11	Outbound Domestic Freight Tons by Truck by Commodity to San Diego	3.15
Figure 3.12	Inbound Origins of Domestic Flows by Truck to San Diego	3.16
Figure 3.13	Outbound Destinations of Domestic Flows by Truck from San Diego	3.18
Figure 3.14	Top 10 Import Commodities by Tonnage Moving through San Diego	3.21

3 GATEWAY REGION: UNDERSTANDING THE IMPORTANCE OF TRUCK CORRIDORS (Cont'd)

Figure 3.15 Top 10 Import Commodities by Tonnage Destined for San Diego 3.22

Figure 3.16 Top 10 Export Commodities by Tonnage Moving through San Diego..... 3.23

Figure 3.17 Top 10 Export Commodities by Tonnage Shipped from San Diego..... 3.24

Figure 3.18 Value of U.S. Content in Imports..... 3.29

Figure 3.19 San Diego Perishables Freight Flows 3.30

Figure 3.20 Domestic Truck Circulation: 2050 Forecast 3.31

Figure 3.21 2012 San Diego Region Truck Tonnage Breakdown 3.32

Figure 3.22 2050 Conservative Forecast San Diego Region Truck Tonnage Breakdown 3.33

Figure 3.23 2050 Midpoint Forecast San Diego Region Truck Tonnage Breakdown 3.33

Figure 3.24 2050 Aggressive Forecast San Diego Region Truck Tonnage Breakdown..... 3.34

Figure 3.25 Supply Chain Relationships Between: International Ports of Entry,
the Ports of Los Angeles/Long Beach, and the Inland Empire..... 3.35

Figure 3.26 San Diego Perishables Freight Flows 3.41

4 POLICY CONSTRAINTS, MARKET CONDITIONS, AND REGULATORY ISSUES

Figure 4.1 Freight Schematic “Dashboard” Policy Challenges 4.1

Figure 4.2 TAMT with Downtown San Diego in Background 4.13

TABLE OF TABLES

3 GATEWAY REGION: UNDERSTANDING THE IMPORTANCE OF TRUCK CORRIDORS

Table 3.1	Truck Tons by Type of Movement, San Diego	3.9
Table 3.2	Truck Tons by Direction, San Diego.....	3.10
Table 3.3	Inbound Domestic Freight by Mode of Transportation.....	3.11
Table 3.4	Outbound Domestic Freight by Mode of Transportation.....	3.12
Table 3.5	Top Inbound Domestic Commodity Flows by Truck to San Diego	3.14
Table 3.6	Top Outbound Domestic Commodity Flows by Truck to San Diego.....	3.15
Table 3.7	Top Inbound Origins of Domestic Flows by Truck to San Diego.....	3.16
Table 3.8	Top Outbound Destinations of Domestic Flows by Truck from San Diego	3.18
Table 3.9	Total International Trade Flows to, from, and through San Diego	3.20
Table 3.10	U.S.-Mexico Trade Flows to, from, and through San Diego	3.20
Table 3.11	Port of San Diego Top Imported Commodities	3.36
Table 3.12	Port of San Diego Top Exported Commodities.....	3.36
Table 3.13	San Diego International Airport Domestic Cargo	3.37
Table 3.14	San Diego International Airport International Cargo.....	3.37
Table 3.15	San Diego International Airport Mail Cargo	3.38
Table 3.16	Port of San Diego Top Exported Commodities.....	3.38
Table 3.17	San Diego International Airport Domestic Cargo	3.39
Table 3.18	San Diego International Airport International Cargo.....	3.39
Table 3.19	San Diego International Airport Mail Cargo	3.40

APPENDICES

Appendix A: Freight Gateway Study Update Technical Memorandum	A.1
Appendix B: Freight Gateway Study Update Forecast Tables	B.1
Appendix C: SANDAG Gateway San Diego Vehicle Vignette	C.1
Appendix D: SANDAG Freight Gateway Study Electronics Vignette Report	D.1
Appendix E: SANDAG Freight Gateway Study Perishable Vignette	E.1

1 EXECUTIVE SUMMARY AND INTRODUCTION TO FREIGHT DYNAMICS IN THE GATEWAY REGION

Transportation infrastructure networks must accommodate and reflect how resources, goods, and services are distributed. In the short run, the health of the economy drives the demand (volume) of freight moving on the transportation system. In the long run; however, it is the capacity of regional transportation systems to accommodate freight volumes, which result from market expansion and other shifts in the structure of the economy, which can significantly impact the sustainability of economic growth.

1.1 Understanding Freight Movement

As recovery in growth in the U.S. economy continues following the Great Recession of 2008-2009, demand for goods, services, and related freight transportation activity is projected to continue to increase. Growth is projected for heavy shipping industries like energy, farming, and mining as well as sectors such as ecommerce, high tech, and the government, which also impact demand for the movement of goods.

The American freight transportation network has been experiencing tremendous growth in the past decades due to changes in the makeup of the economy and expansion in international trade. While the growth in the past 30 years was fueled by declines in transportation and communication costs, trade is expected to grow further as global economies become increasingly interdependent.

Shifts in established patterns of international trade will contribute to this growth, and that includes a trend towards ‘near-shoring’¹ of production to Mexico for the North American market with some shifting away from overseas production that is no longer based only on low labor costs. This trend particularly benefits Mexico as a rapidly growing source for U.S. imports, echoing the boom in crossborder trade that followed the original adoption of the North American Free Trade Agreement (NAFTA) twenty years ago. The recent trend is for the United States and even Asian and European manufacturers to expand production in Mexico, often referred to as “near-shoring” in order to serve the entire North American market, often with advanced technologically manufactured goods.

According to the U.S. Department of Transportation’s (U.S. DOT) Freight Analysis Framework (FAF) version 4, the volume of U.S. NAFTA trade will more than double between 2012 and 2050, as will the volume of all imports and exports over the same period. As a result, there is growing pressure to maintain, upgrade, and expand the current freight transportation network to meet the demands of various U.S. and international markets.

¹ Dictionary of International Trade definition: “The offshoring of a business process or manufacturing plant to a lower cost foreign location that is in close geographic proximity to the contracting company.”

U.S. energy markets are also undergoing a revolution with the rapid growth in use of natural gas, due to lower prices from increased domestic production of both natural gas and oil, facilitated by new well drilling technologies. The import transportation requirements for U.S. crude oil consumption are falling while the United States expands transportation of natural gas for export, including via pipeline to Mexico. Lower relative energy costs are resulting in increased demand for transportation of North American production of energy-intensive products such as petroleum products and chemicals. Natural gas also is seeing adoption as an alternative fuel source for freight transportation equipment, including for over-the-road heavy trucks, due to the attraction of reduced emissions and reduced costs.

Across industries and across the continent, in order to remain competitive, firms are demanding more timely and flexible delivery services that require the current freight system to become more efficient and reliable. The interconnectedness of various modes of transportation is growing in importance, especially at international gateways such as border crossings, airports, and seaports.

1.2 The Role of Freight Movement in the National and Regional Economy

The relationship between freight transportation and economic growth has long been recognized as an important element in any national or regional development policy.

Enhancing freight transportation networks can lead to significant economic impacts by lowering transportation costs and improving service, particularly with today's just-in-time (JIT)² inventory practices. Network improvements can help increase practical distances traveled and the speed of delivery, further expanding supply and distribution networks, resulting in market development and economies of scale.

Improving freight transportation services by reducing transit times and improving reliability enhances inventory and supply chain management. The effects of these time savings and cost reductions can work through the economy via additional efficiency gains due to changes in companies' logistics processes and operations, also known as "reorganization" effects.

² Dictionary of International Trade definition: "The principle of production and inventory control that prescribes precise controls for the movement of raw materials, component parts, and work-in-progress. Goods arrive when needed (just in time) for production for use rather than becoming expensive inventory that occupies costly warehouse space."

Figure 1.1: Freight Transportation and Economic Growth

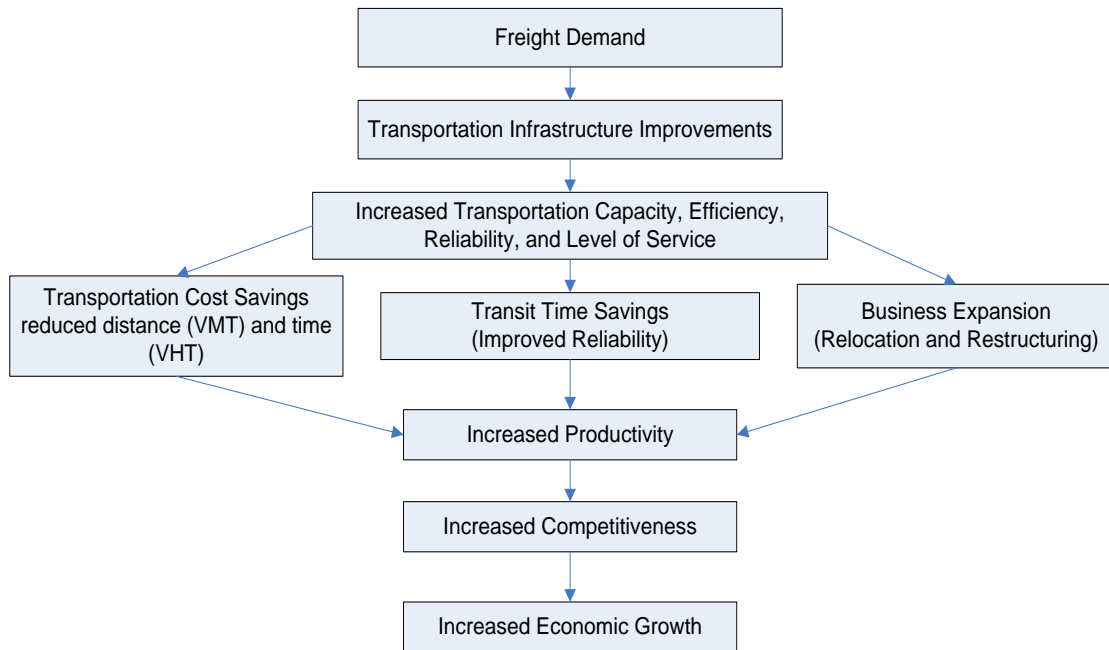

NOTE: VMT is Vehicle Miles Travelled; VHT is Vehicle Hours Traveled

The time and cost savings generated by investments in the freight transportation network can enhance the overall performance of logistics systems, which in turn can increase productivity in manufacturing and distribution, as depicted in Figure 1.1. This enhanced productivity reflects a more efficient use of labor, capital, and materials, all of which lead to improved production and increased economic growth. The concept of productivity enhancement is fundamental in economic theory as it is a key determinant of economic growth and improvement in the standard of living, as exhibited by the close relationship between how much economic output there is per person (measured as Gross Domestic Product [GDP] per capita) and the growth of labor productivity.

Figure 1.2: U.S. Gross Domestic Product and Trade (2002 – 2014)



Source: Bureau of Economic Analysis and International Trade Association, U.S. Department of Commerce

In the United States, there is a clear relationship between the size of the country's economy, measured as GDP, and U.S. international trade; this is depicted in Figure 1.2. U.S. GDP and international trade have continued to grow since 2002 (with the Great Recession and global energy correction as the exceptions in 2009 and 2015). As U.S. trade has grown faster than the overall economy over this period, a comparison of U.S. international trade to GDP shows an increasing trend. This represents the increasing importance of trade to the U.S. economy.

Figure 1.3: Percentage Change in World Trade and Output

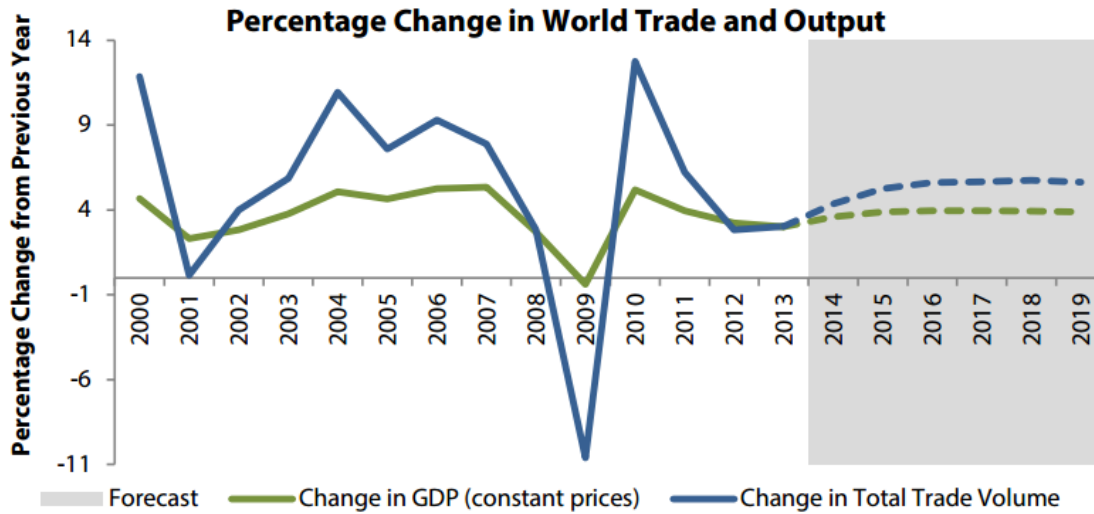

Source: International Trade Association, U.S. Department of Commerce

The relationship between trade and economic growth of the United States also is found at the global level. Figure 1.3 illustrates the relationship of trade and GDP for the world. Except for the global recession years of 2009 and 2001, the pace of world trade growth has equaled or exceeded overall world economic growth. Despite the 2012-2013 weakness in world trade growth relative to GDP, the International Trade Association forecasts that the world economy reverts to the long-term trend of trade volume outpacing GDP.

Figure 1.4: Trade Growth and Economic Growth by Metropolitan Area

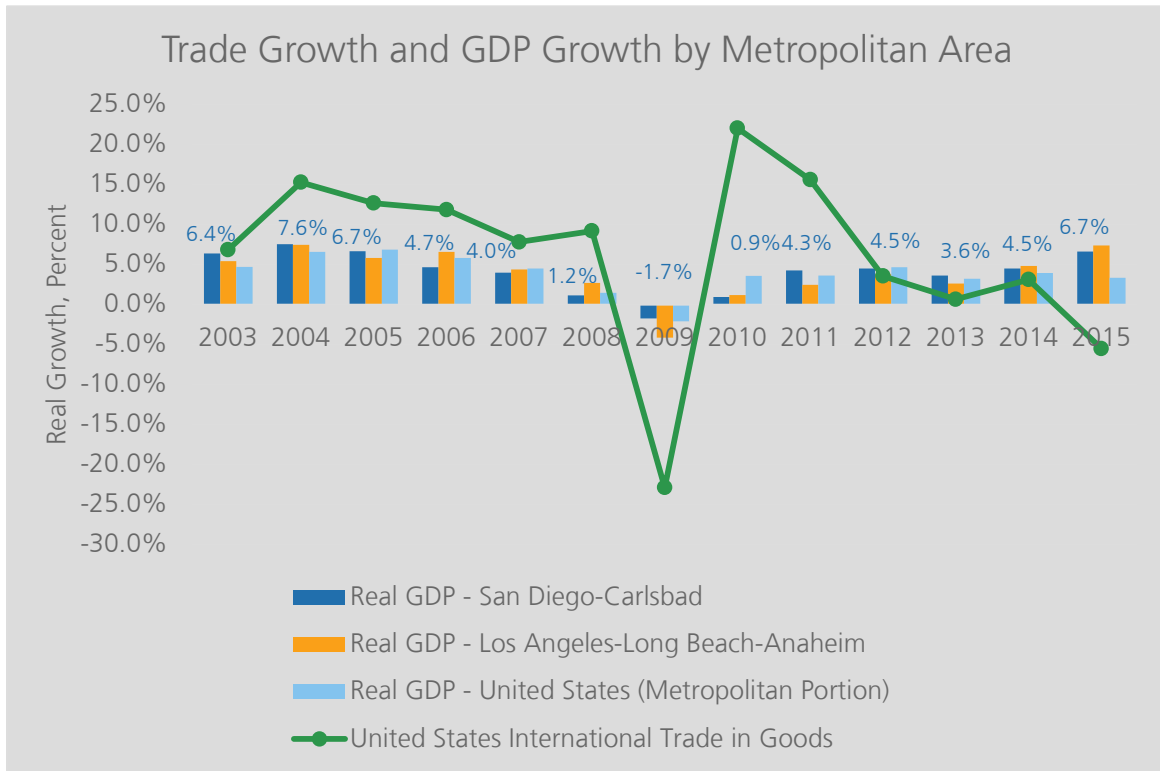

Source: Bureau of Economic Analysis and International Trade Association, U.S. Department of Commerce

The regional economy of the San Diego Metropolitan Statistical Area (MSA)³ has performed strongly compared to its Los Angeles and Orange County MSA and U.S. Metropolitan peers in recent years. Measured as real regional GDP in the bar graph in Figure 1.4, San Diego's growth has been stronger than that of Los Angeles and Orange County since the recovery from the Great Recession took hold in 2011. In 2015, the annual GDP growth for the Southern California metropolitan regions outperformed that of the U.S. international trade growth in goods. This recent trend is similar to the U.S. GDP and trade as shown in Figure 1.2, as GDP has outpaced trade during the global energy correction.

The effects on the economy of improving freight transportation can be classified into different groups, some of which have been used to quantify benefits for use in economic feasibility analysis⁴ of freight transportation projects. Immediate cost reductions to carriers and shippers, including gains to shippers from shorter transit times and better reliability, represent the first group of quantifiable benefits. A second group of quantifiable benefits includes gains associated with reorganization effects (improved logistics), leading to lower prices and higher output. These, in

³ U.S. Census Bureau definition: Metropolitan Statistical Areas are geographic entities delineated by the U.S. Office of Management and Budget for use by federal statistical agencies in collecting, tabulating, and publishing federal statistics. A metro area contains a core urban area of 50,000 or more population. Each metro area consists of one or more counties and includes the counties containing the core urban area as well as any adjacent counties that have a high degree of social and economic integration (as measured by commuting to work) with the urban core.

⁴ Economic feasibility analysis of projects is most commonly carried out using Benefit Cost Analysis.

turn, can result in a third group of quantifiable benefits, made up of product/service improvements, or in the development of new products/services.

Finally, investments in freight transportation can lead to higher employment and income, which, in turn, helps to stimulate the economy. The real cost of freight transportation has decreased over the past three decades, primarily as a result of industry restructuring and innovations in supply chain management. However, recent trends such as volatile oil prices, growing environmental concerns, transportation safety regulations, and reductions in public funding available for capacity expansion, may lead to higher freight transportation costs and impede growth in goods movement in the near future. In particular, capacity issues have resulted in congestion problems across major freight corridors and gateway access points. Congestion significantly impacts the supply chains of high-value, time-sensitive commodities, and contributes to higher freight costs, which may ultimately result in higher consumer prices and a reduction in export competitiveness across the economy. Consequently, strategic investments in major freight corridors and gateway access points are essential to contain and/or mitigate rising transportation costs.

1.3 Characteristics of and the Challenges to the Regional Freight Network

Uniquely located between major production, trade, and population centers, the San Diego and Imperial Valley region – the Gateway region – possesses a wide array of transportation infrastructure assets. These include major ports of entry (POEs) along the border with Mexico (including Calexico East’s unique aggregate only conveyor belt), interstate highways and state routes, Class I and short line railroads, marine cargo terminals, pipelines, and a modern air cargo system.

The location of the Gateway region contributes greatly to its role in global supply chains and the facilitation of international trade. The border crossings are critical assets for the physical movement of goods, as they serve as gateways to and from the U.S./NAFTA⁵ trading partner Mexico; similarly the two marine terminals are gateways for waterborne commerce and the San Diego International Airport (SDIA) hosts a significant amount of air cargo and courier services, and some air cargo is handled at the Imperial County Airport. Links to the gateways (highways, pipelines, and rail lines) are equally important, as they provide the connection to the gateways that facilitate the circulation of goods between producers and consumers.

The freight infrastructure network serving trade is critical, given how significant trade is to the economy. Because of the integration of production and distribution processes across the California/Mexico border, the growth in international trade not only benefits the national economy, but the regional economy as well. Economic growth in the region has been closely related to international trade and more specifically to NAFTA trade, for decades. Figures 1.5 and 1.6 show the value of the San Diego economy (as Gross Regional Product) and trade (as Otay Mesa trade for San Diego) between 2001 and 2013. The figures suggest a strong correlation between trade and the economy of the San Diego region, both having recovered from the declines during the Great Recession.

⁵ NAFTA is the North American Free Trade Agreement covering the U.S., Mexico, and Canada, in force since 1994.

Figure 1.5: San Diego Trade and Economic Growth are Correlated

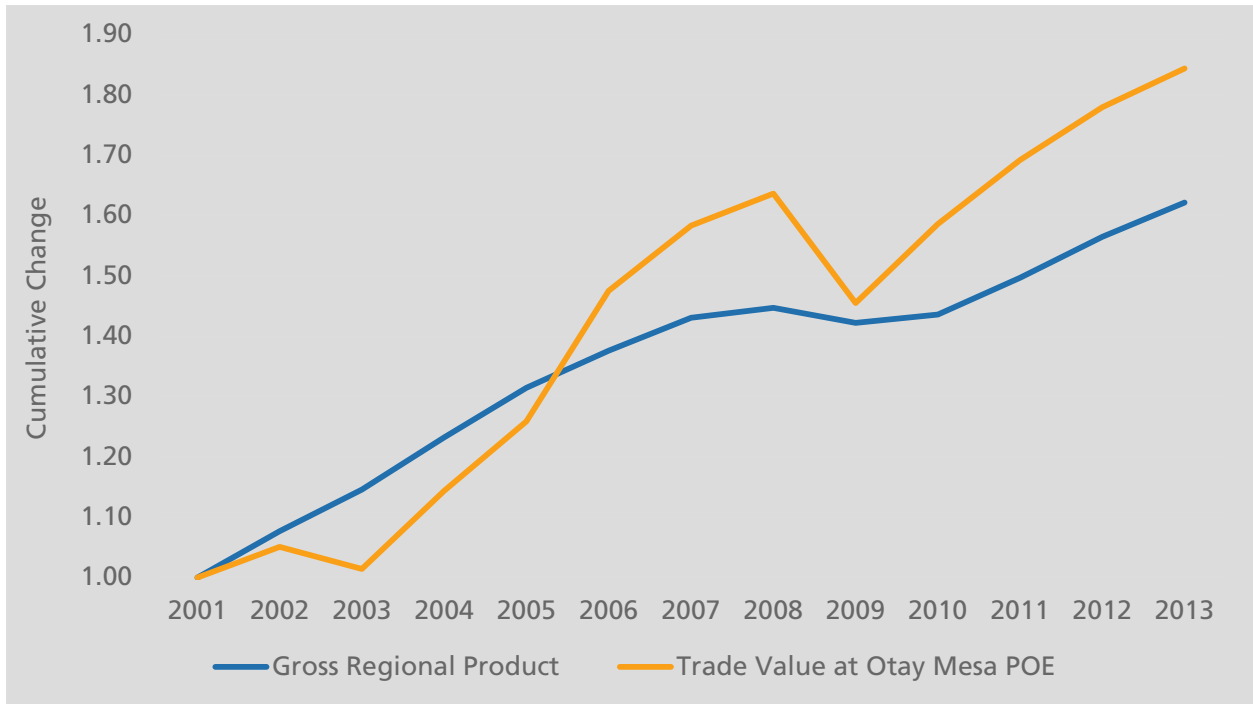

Source: SANDAG

The value of trade at the Otay Mesa POE (California's largest POE with Mexico) is large, valued at \$42.7 billion in 2015. This trade consists of northbound U.S. imports (\$28.2 billion) dominating the two-way trade as observed in the pie chart in Figure 1.6 as well as southbound exports (\$14.5 billion). This trade is carried by over 1.6 million northbound and southbound truck crossings annually. Among the key commodities in this two-way trade are electronics, agricultural goods, vehicles, and medical devices.

Figure 1.6: Large San Diego – Mexico Trade is Dominated by U.S. Imports

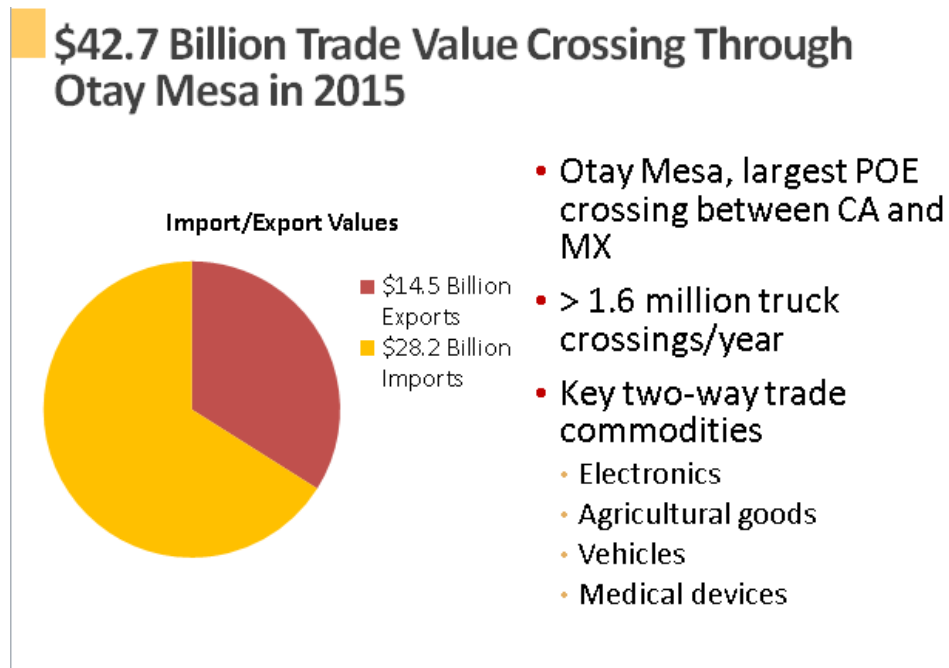

Source: U.S. Department of Transportation Transborder Freight and BTS

U.S./Mexico trade has grown substantially since the adoption of NAFTA over two decades ago in 1994. As seen in the next Figure 1.7, the U.S. Department of Commerce statistics show the total value of this bilateral trade has increased 552 percent from 1993 before the beginning of NAFTA to 2015. Both imports and exports rebounded strongly after the 2008-2009 recession to record high levels.

Figure 1.7: Annual U.S. Imports and Exports since the North American Free Trade Agreement

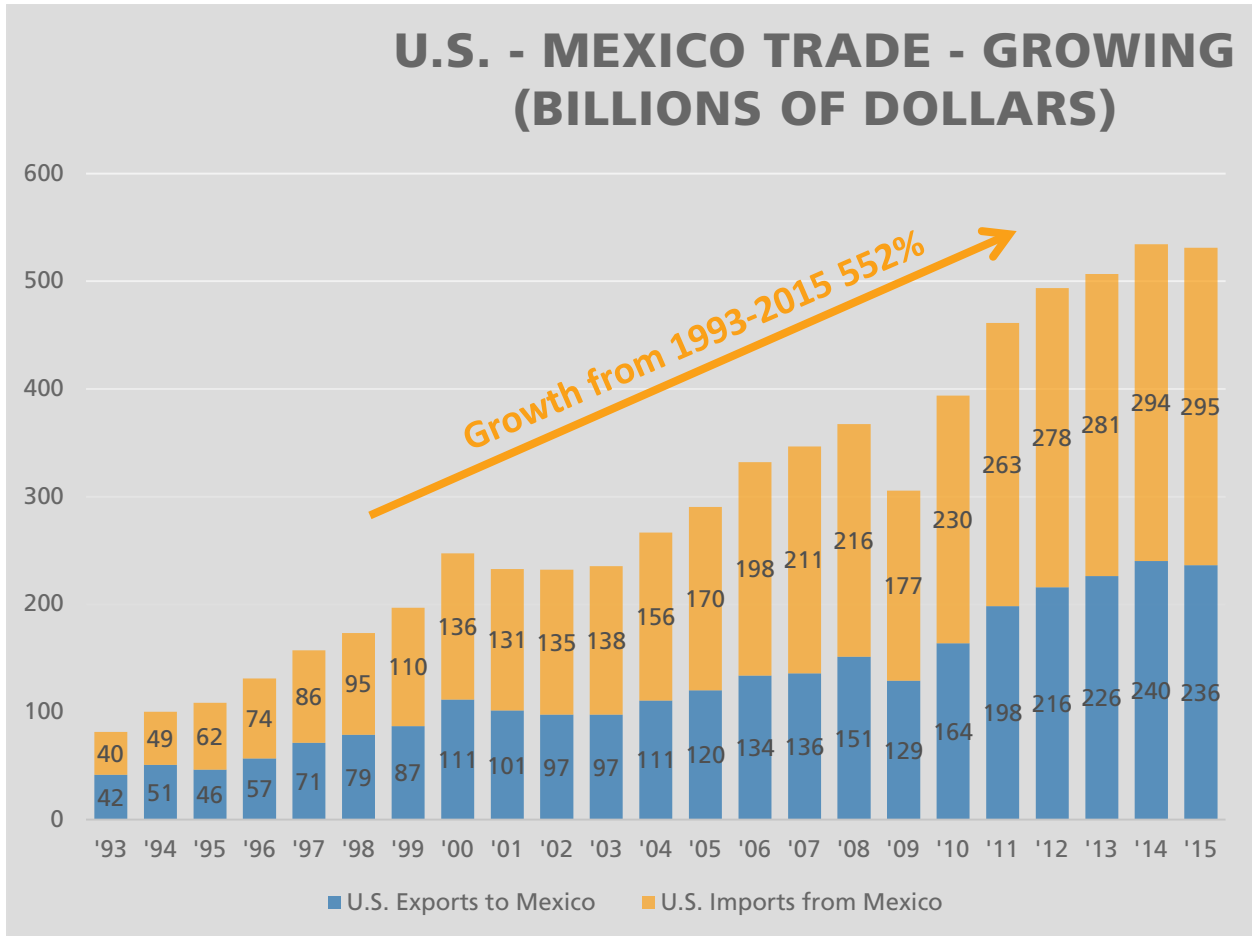

Source: U.S. Department of Commerce

The trade in intermediate goods, those used as inputs to manufacturing production, is substantial between the United States and its North American trade partners. The integration of North American manufacturing supply chains is demonstrated by the high share of the value of goods imported into the United States comprised of components and inputs that originated in the United States. Examples would be electronic products assembled in Mexico with electronic parts made in and imported into Mexico from the U.S. This production sharing across countries is evidence of the economic integration between two economies, and the dependence on the crossborder transportation system to enable this commerce to occur. In Figure 1.8, Mexico is by far the leading “production sharing” trade partner country of the United States with 40 percent of the value of U.S. imports from Mexico comprised of U.S. content. The key U.S. trade partners across the Pacific Ocean, in contrast, all have less than 10 percent U.S. content in the goods the U.S. imports from them.

Figure 1.8: Integration of U.S. Trade with Mexico and Other Trade Partners

Production Sharing: Value of U.S. Content in Imports

• Mexico	40%
• Canada	25%
• Malaysia	8%
• Korea	5%
• China	4%
• Brazil	3%
• European Union	2%
• Japan	2%
• India	2%

Source: National Bureau of Economic Research: NBER Working Paper Series Give Credit Where Credit is Due: Tracing Value Added in Global Production Chains

A well-functioning freight transportation system (gateways and links between the gateways) also is essential to satisfying local demand for consumer products and maintaining standards of living. This is particularly true of **terminating markets** such as the Gateway region. Goods movements terminating in the region (“inbound” freight flows) exceed goods movements originating in the region (“outbound” freight flows). In order to accommodate the projected growth in population and employment - and the associated growth in consumption - it is important to understand that more inbound freight flows and overall freight volumes are implicit in enabling that growth.

Currently, the highway system carries the vast majority of regional freight, but the system is strained at key bottlenecks. Congestion at the border crossings between California and Mexico is hindering the region’s economic growth.

Other factors are restraining the region from reaching its potential for prosperity and improvements in standards of living. One of the main problems is the limited growth in regional income, attributed to an increasing proportion of low-wage employment. There also has been a widening gap between average wages for high and low earners. And a relatively high cost of living from housing and energy expenses has challenged the economic standing for a majority of the population.

Figure 1.9: San Diego Regional Vision



To provide innovative mobility choices and planning to support a sustainable and healthy region, a vibrant economy, and an outstanding quality of life for all.

Source: San Diego Forward: The Regional Plan

Regional policy makers are faced with a complicated set of challenges to the region's growth and to the realization of its goals for greater prosperity. On the one hand, inefficiency in the movement of freight threatens the rate of growth in economic productivity, thereby posing a risk to regional competitiveness, employment, and real household incomes. On the other hand, facilitating the unconstrained demand for freight transportation can bring with it environmental and other social costs that diminish overall prosperity and well-being. How to respond to the future growth in freight transportation demand will thus require a balance in planning decisions, as depicted in the Regional Vision in Figure 1.9.

1.4 Policies and Potential Impacts of Sustainable Goods Movement in the Region

Gateway region policymakers face the complex task of enhancing mobility for the region's residents, workers, and businesses while at the same time promoting international trade by improving the efficiency of the Gateway region's airports, seaport, and border-crossings. To assist in this task, it is helpful to identify types of infrastructure investments that will best contribute to economic growth. To enhance efficiency at the international gateways, the strategies adopted must accommodate growing needs to reduce congestion and waiting times. Finally, businesses must be able to take advantage of scale economies as well as agglomeration economies from consolidation of production and warehousing facilities. Ultimately, a more efficient and improved Gateway region transportation system will support mobility and trade growth.

When considering options for improving the region’s standard of living, planners and policymakers in the Gateway region have an interest in promoting a wider understanding of the impact of improving freight infrastructure, policies and services, and in addressing related economic, environmental, and social issues. Example questions include:

- What investments would help support trade among sectors of the economy associated with higher wage employment and higher value products?
- Should the region promote growth in more value-adding activities? And if so, of what types?

Strategies for improving the region’s transportation system generally fall into three categories:

- What policy actions can promote local business connections or access to labor and other inputs?
- What policy actions are needed to promote environmental benefits and/or community sensitive responses?
- Which infrastructure investments can alleviate bottlenecks, improve efficiencies, and/or lower costs?

Whatever combination of strategies is pursued, regional policy makers will want to focus on how to improve the region’s comparative advantage (e.g., proximity to Mexico’s manufacturing industry, high quality labor force, attractive location for tourism) while ensuring that their policies are consistent with the strategies and initiatives pursued on the Mexican side of the border.

To address the need for planning for a more efficient and reliable transportation system that will better serve the region’s growing population, SANDAG is seeking to better integrate existing transportation system components in the updated Regional Transportation Plan (RTP), titled San Diego Forward: The Regional Plan. Among other elements, the plan includes an extensive set of managed lanes to accommodate transportation services as well as carpools, vanpools, and fee-paying patrons. It would help improve accessibility for various traffic types and – indirectly – activities, and provide funding incentives for transit-oriented, sustainable land use and development.

SANDAG’s planning also is taking into consideration the new federal freight-planning guidance, as recommended by the U.S. DOT in their implementation of the latest federal surface transportation program, known as the *Fixing America’s Surface Transportation Act* or “FAST Act”, legislation. Along with a continued emphasis on freight planning and performance management in general, this legislation calls for the implementation of shovel-ready projects through both discretionary grant and state-issued formula fund programs. The legislation endorses the type of freight-planning already established and underway by SANDAG, and through the State of California, provides implementation funding opportunities.

In response to the need to maintain and improve the region’s access to domestic and international markets, SANDAG includes a goods movement discussion in the Regional Plan. This section aims to assess the region’s goods movement system, and identify opportunities and needs for freight system improvement. SANDAG freight-planning also works with Caltrans, neighboring planning agencies,

and the U.S. DOT in establishing definitions of a national freight network that can be used to help guide inter-regional corridor planning. The U.S. DOT has defined a national Primary Highway Freight System (PHFS) that is called for in the FAST Act legislation to also help guide freight transportation policy decisions.

Additionally, as part of the recovery from the Great Recession, federal government stimulus project funding such as from the DOT Transportation Infrastructure Generating Economic Recovery (TIGER) program has provided funds for some freight-related projects in the region. The TIGER program was continued with grant funding of \$600 million in 2014, which may again prove a source of support for the region's project needs. The State of California Proposition 1B Bond funding also included freight-specific project funds, especially for rail. Traditional federal funding opportunities are challenging for any sort of systemic freight improvements; in the San Diego and Imperial County region this is particularly true for border infrastructure needs due to budget constraints. Regarding border financing, there is a new tool that addresses this problem; Section 559 of the Consolidated Appropriations Act, 2014, is a component of CBP's alternative sources of funding. This authority allows CBP to support requests for expanded services as well as improvements to infrastructure through both reimbursable service agreements and donation acceptance authority, respectively.

Through innovative financing mechanisms such as public-public partnerships, SANDAG, Caltrans, and the U.S. Customs and Border Protection, together with counterpart agencies in Mexico are exploring new infrastructure investment partnerships. Similarly, the freight infrastructure challenges for the SDIA and the seaport are often the landside access issues, where unique partnerships and blended funding solutions have to be developed. Although such partnerships usually require lengthy negotiations among the participants on issues concerning design, construction, and control over operation and maintenance, they could help pay for building and maintaining infrastructure networks that the region cannot otherwise afford.

While policies aimed at encouraging international trade could improve the efficiency of the transportation network and support sustainable growth in the region, they might also lead to business restructuring and re-allocation that could eventually shift jobs and production. This speaks to why SANDAG will be balancing three basic goals: maintaining a vibrant economy, encouraging innovative mobility and planning, and maintaining a healthy environment and communities.

SANDAG will use this updated Freight Gateway study in partnership with organizations such as the Southern California Association of Governments (SCAG), the Imperial County Transportation Commission (ICTC), the San Bernardino Associated Governments (SANBAG) the Orange County Transportation Authority, the California DOT (Caltrans), and the Unified Port of San Diego and San Diego International Airport Authority in order to jointly work towards advancing public support for trade and the infrastructure needed to accommodate trade. For example, joint efforts could involve raising the public's awareness and understanding of trade negotiations in conjunction with labor and environmental policies, and other policies to protect intellectual property rights or domestic industries.

There is a clear interdependency between SANDAG, SCAG, and ICTC in planning for crossborder freight movements and regional intermodal freight. The diagram in Figure 1.10 shows an example of regional distribution schematic of crossborder, international, and domestic intermodal freight in which the capacity links, nodes, and bottlenecks exist across planning jurisdictional lines. In

Southern California, National Distributions Centers (NDCs) and Regional Distribution Centers (RDCs) are located in the Los Angeles Basin and the Inland Empire. They are connected to the major Southern California container port gateways of Long Beach and Los Angeles by truck, and in turn connected to the rest of the country via truck and intermodal rail service. Mexico traffic connects through San Diego at Otay Mesa POE to the seaports, the distribution centers, and the intermodal rail terminals in the Los Angeles Basin. There also are intermediate freight handling facilities in the region used in the network, depicted by the orange boxes in the diagram. The depiction of interdependency of the many relationships across the border is conceptual in Figure 1.10. A major goal of this update study is to: illustrate the complexity of global supply chains, suggest the region's role in facilitating those supply chains, and how to forge cooperative approaches for researching and planning for these supply chain flows.

Figure 1.10: Los Angeles Basin/San Diego Truck Distribution Interdependency

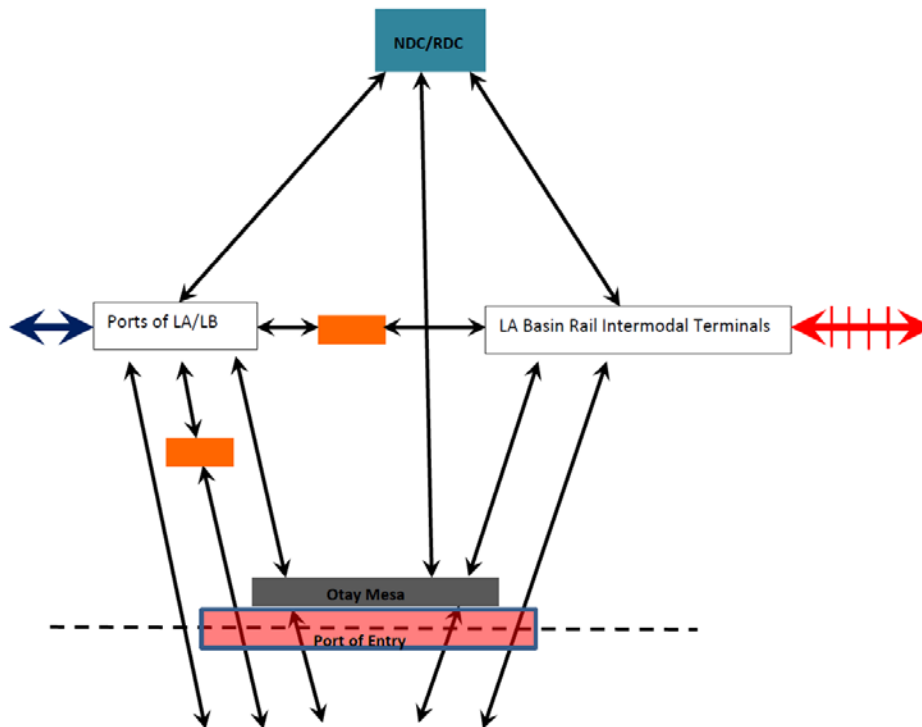

NOTE: NDC: National Distribution Centers; RDC: Regional Distribution Centers

With limits on funding, it is imperative that freight infrastructure investments be prioritized and allocated efficiently. Such planning not only requires a clear understanding of existing capacity and current capacity utilization, but more importantly, an accurate and reliable forecast of future transportation and infrastructure needs.

1.5 Study Objective and Plan of this Report

The objective of this study is to update the 2010 SANDAG Comprehensive Freight Gateway Study to provide an accurate, reliable, and credible forecast of future freight movements, to better plan for the various facilities and infrastructure improvements in the Gateway region. This updated Freight Gateway Study gives the region benchmarks to assist with the freight investment and freight policy issues noted earlier. The study will also underpin *San Diego Forward: The Regional Plan*.

Another critical component of this update is to identify and annotate the impacts of the Great Recession and then update the future forecasts.

After this introductory chapter, Chapter 2 provides an updated detailed description of existing infrastructure and capacity constraints in the region. Chapter 3 provides new estimates of existing freight flows; the chapter also includes snapshot information about major commodities, and mode of conveyance. The policy constraints, market conditions, and regulatory issues affecting the transportation under this study are addressed in Chapter 4. The technical appendices include several items:

- An overview of the methodology and a list of data sources
- The updated 2050 freight forecast gateway tables; a compendium report distilling mode of conveyance, and volume and value illustrating various commodities and gateways
- Freight vignettes – perishables, electronics, and automobiles

1.6 Gateway Tables: Summary Snapshots of Regional Freight

As noted in Section 1.4, the subsequent chapters delve into greater detail on regional freight issues, but the following summary snapshots will inform the reader of key freight issues. It is important to note in this introductory section that most of the freight data in this report used a common metric, which is measuring freight dynamics by cargo weight in tons.⁶ Assessing freight flows by tons is a very useful metric that is common to all modes and to all gateways. So rather than counting containers, train carloads, truckloads or pallets of air cargo, in this report we will focus on tons. By using tons, we then have a study whereby gateways can be compared and understood through a common lens. It is important to understand that this is a Comprehensive Freight Gateway Study and is not intended to be used as a project-specific traffic study.

⁶ Tons measured as short tons of 2000 pounds

Figure 1.11 Summary of Freight Flows through the Region’s International Gateways in Volume: 2050 Forecast

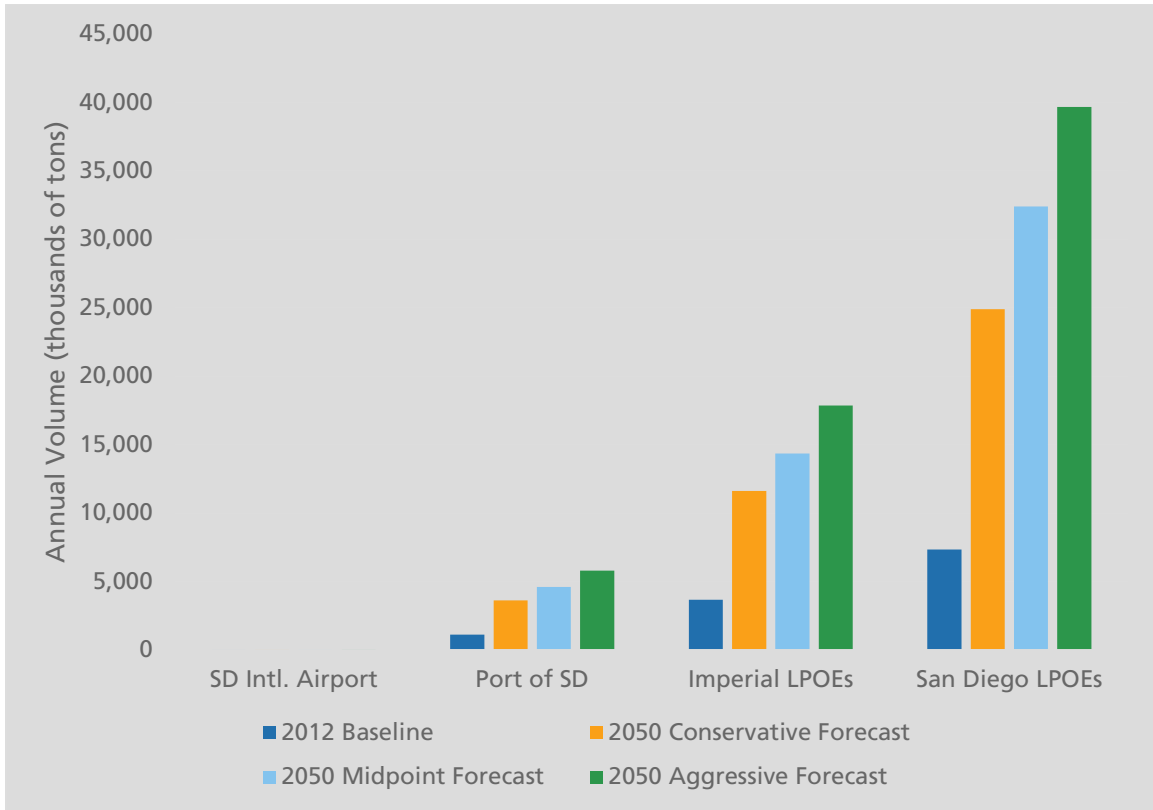

Source: FAF 4, U.S. Army Corps of Engineers and San Diego International Airport,

In Figure 1.11, it is clear that both San Diego and Imperial Counties land ports of entry reflect the highest amount of combined import and export tonnage and highest annual average growth rates between the 2012 baseline and 2050 conservative and aggressive forecasts. A substantial majority of total tonnage for these counties are moved through the Otay Mesa (over 90 percent) and Calexico East (over 95 percent) POEs. The San Diego International Airport’s tonnage is not comparable (due to the high value commodities that move by air freight) to the other major international gateways; all other international gateways witnessed over 1 million tons moved during the 2012 baseline, but the airport only witnessed six thousand.

Figure 1.12 Summary of Freight Flows through the Region’s International Gateways in Value: 2050 Forecast

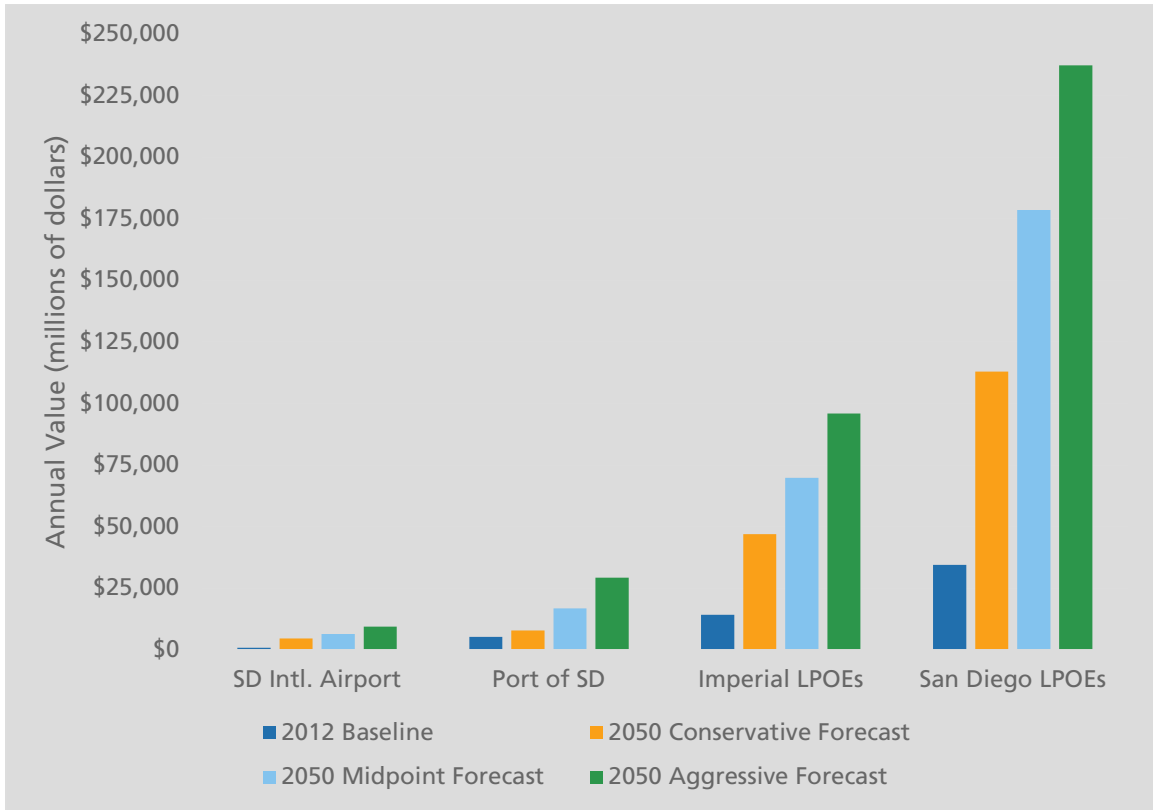

Source: FAF 4 and Bureau of Transportation Statistics

Similarly, as with tonnage, in Figure 1.12, San Diego and Imperial Counties LPOEs are substantially leading the region’s gateways in combined import and export trade value. During 2015, the Otay Mesa POE witnessed over \$42 billion in total trade value. By 2050, this POE is estimated to witness a significant increase as San Diego County is forecasted to generate total trade value between \$113 to \$237 billion. The Port of San Diego is estimated to generate between \$8 to \$29 billion in value for its imports and exports by 2050; followed by \$4.5 to \$9.5 billion from the San Diego International Airport.

Figure 1.13 Summary of Domestic Freight Flows within, from and to San Diego County in Volume: 2050 Forecast

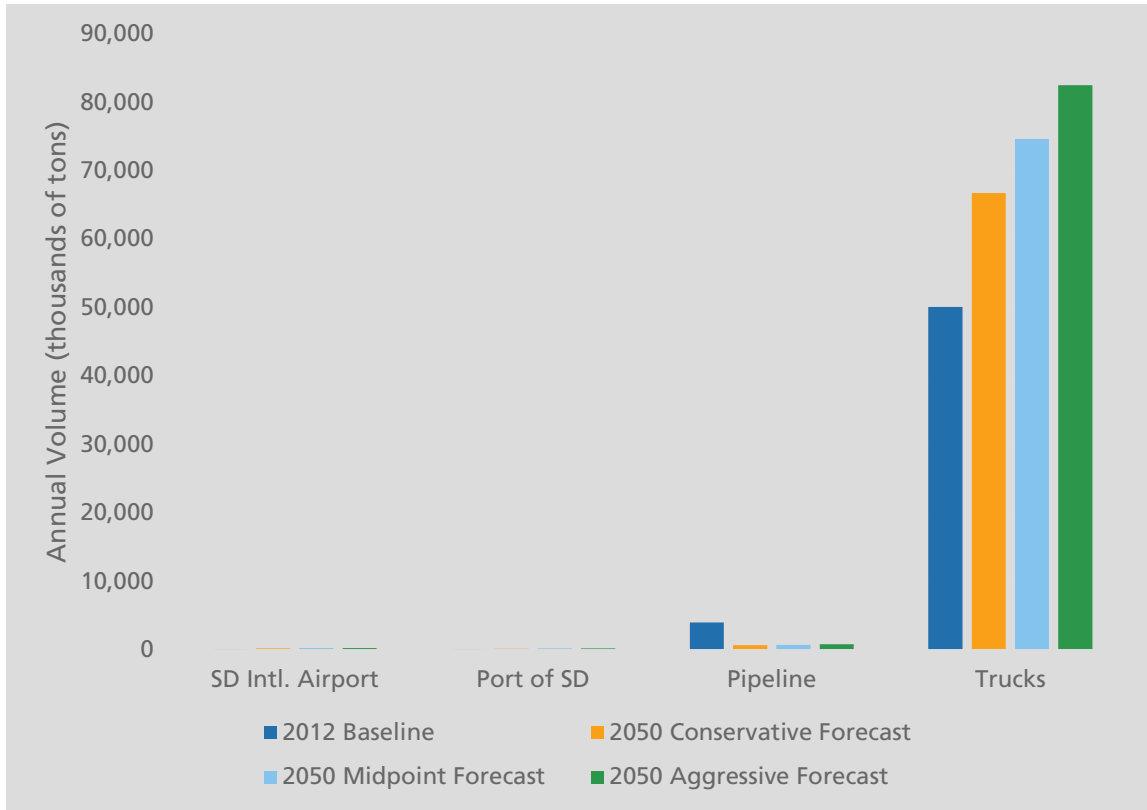

Source: FAF 4, U.S. Army Corps of Engineers, San Diego International Airport, and SFPP, L.P.

As a mode, in Figure 1.13, truck freight flows within, from and to San Diego County reflect over 20 times more volume when compared to other modes in the 2050 conservative and aggressive forecast years. This clearly illustrates the importance of the need for continued investments and maintenance in regional highway networks in order to support these truck volumes.

Figure 1.14 Summary of Domestic Freight Flows within, from and to San Diego County in Value: 2050 Forecast

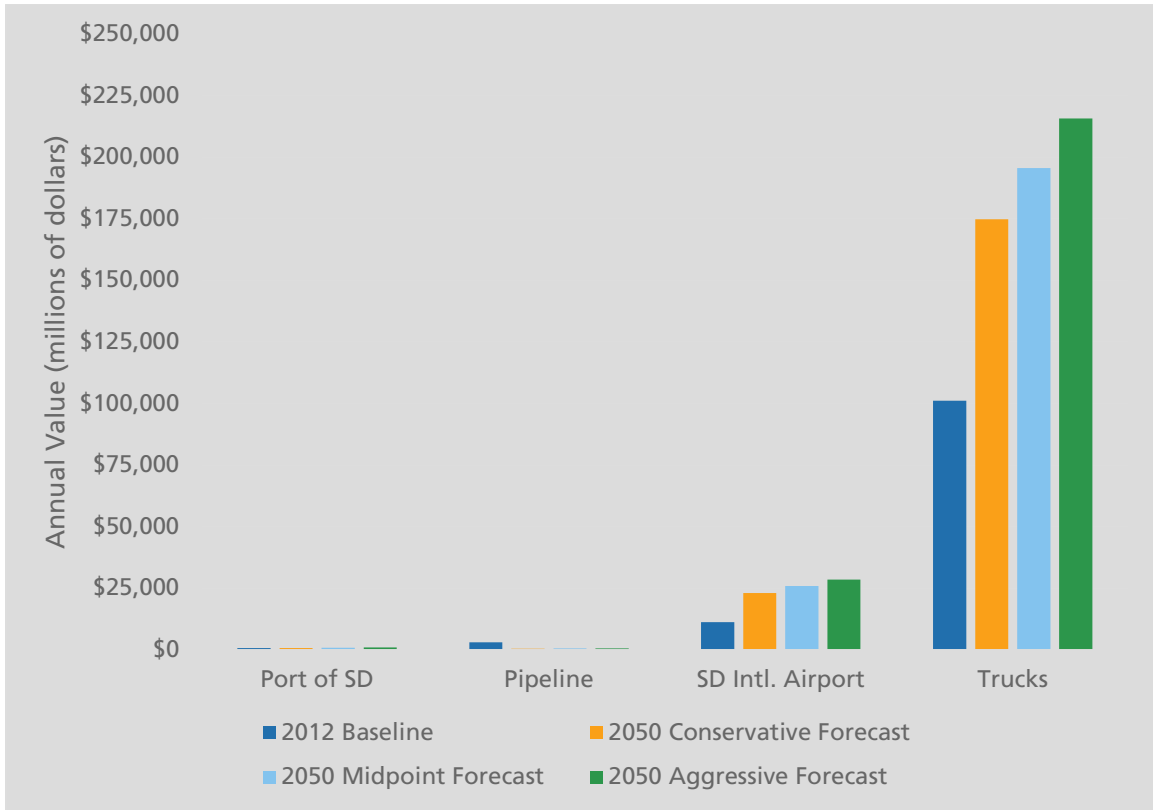

Source: FAF 4 and Bureau of Transportation Statistics

Similar to the situation where the Otay Mesa and Calexico East international gateways are the highest generators in value, the truck mode substantially provides the highest amount of domestic freight flows moving within, from and to San Diego County of the modes of transport. This is depicted for 2012 and 2050 conservative and aggressive forecasts in Figure 1.14.

Figure 1.15 Summary of Domestic Truck Freight Flows within, from and to San Diego County and Comparison to the Region’s International Gateways: 2050 Forecast

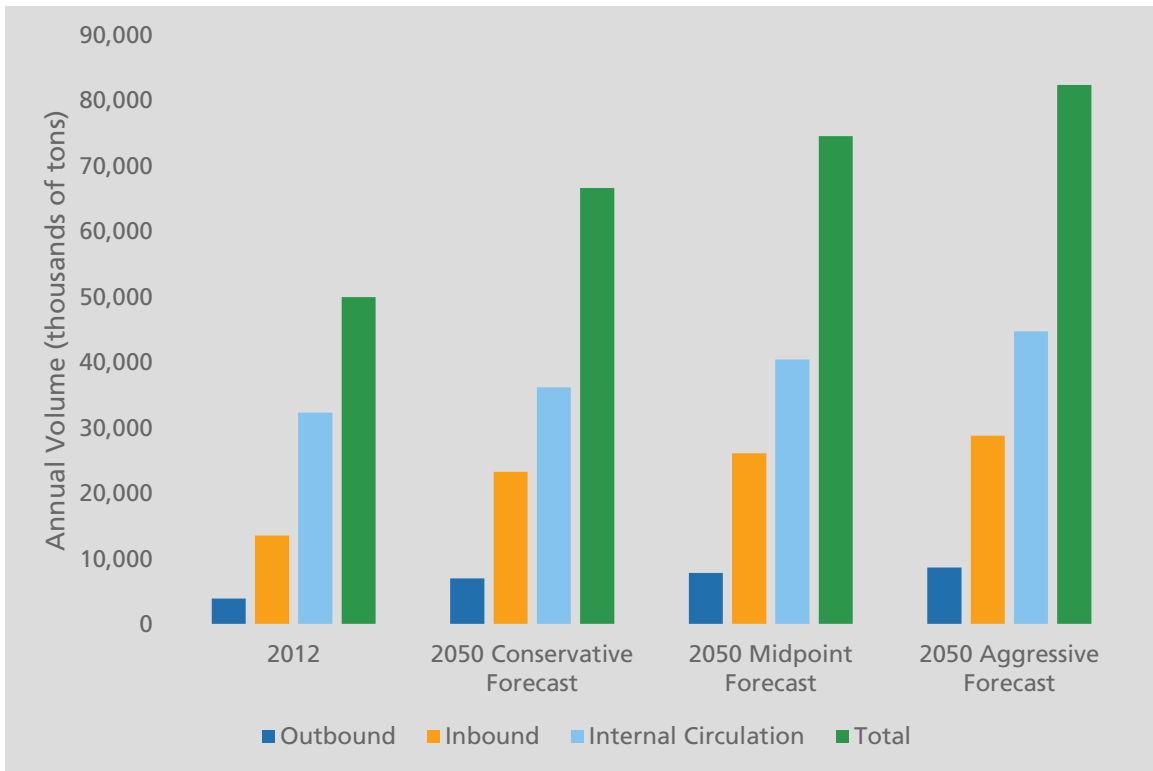

Source: FAF 4

For perspective on the composition of truck demand within, from and to the San Diego region, understanding domestic freight tonnage (in contrast to international tonnage which is identified as Gateway tonnage) is an important part of the overall freight flow picture. The domestic tonnage is important for an understanding of all truck traffic in the region whether it originates at a gateway or is simply the flow of goods to consumers in the San Diego region.

To illustrate the relative importance of domestic truck flows, consider that the international border POEs are estimated to generate between nearly 40 to 55 million tons of import and export truck freight flow demand in 2050 (Figure 1.13), domestic truck freight flows are estimated to generate between 68 to 83 million tons of goods moved as shown in Figure 1.15. Domestic freight flows include internal truck moves within the County of San Diego as well as inbound and outbound truck moves to and from the region and generated domestically within the United States. This domestic freight tonnage, borne by truck, has important implications for maintaining capacity on I-5 and I-15.

2 REGIONAL FREIGHT INFRASTRUCTURE PROFILE

This chapter presents an overview of the freight infrastructure for San Diego County, Imperial County as well as the Baja California region, and changes since the last Comprehensive Freight Gateway Study. The chapter is subdivided into three major sections; San Diego County Infrastructure, Imperial County Infrastructure, and the infrastructure for the northern portion of the State of Baja California, Mexico. Within each section, the freight infrastructure is broken down into five major categories, namely, roads, rail, ports, airports, and warehouse facilities.

2.1 San Diego County Freight Infrastructure

2.1.1 Road Network and Ports of Entry

San Diego County's roadway network supports flows from the freight gateways including other Southern California major gateways and industrial centers as well as the internal distribution of goods. The regional highway network is the metaphorical circulatory system for high volumes of both vehicular travel and freight movements. The highway system carried nearly 95 percent of the goods that moved in and out of the region in 2012. While the existing infrastructure is considered adequate, population growth and an increase in foreign trade activity over the past few decades have resulted in a reduction in the overall mobility in recent years. The reduction in freight activity as a result of the Great Recession along with the completion of key infrastructure projects has at least temporarily increased mobility in some corridors since 2008.

2.1.1.1 Land Ports of Entry

The gateway region is connected across the border with Baja California via six land ports of entry (POE).

The **Otay Mesa** POE is the largest commercial crossing along the California/Mexico border and handles the second highest volume of trucks and third highest dollar value of trade among all U.S./Mexico land border crossings. It is located approximately 15 miles south of Downtown San Diego and 14 miles inland from the Pacific Ocean. On the U.S. side, the crossing connects with California State Route 905 (SR 905), providing links to SR 125, Interstate 805 (I-805) and I-5, and I-15. The facility includes¹ ten total northbound truck lanes of which six are regular commercial lanes, three are commercial FAST lanes, and one is an empty truck lane. Additionally, there are three southbound commercial lanes. Also in the northbound- direction, there are 13 passenger lanes with varying lane configurations dependent upon demand, including 1-10 regular lanes, 1-8 READY lanes, 1-4SENTRI lanes and one bus lane. Additionally, there are three southbound passenger vehicle lanes. The Otay Mesa facility provides a full range of cargo processing functions, including inspection, data collection, and data verification.

¹ Source: Caltrans, Otay Mesa POE Freight Planning Fact Sheet, July 2014. NOTE: The number of each type of lane available varies depending upon demand and staffing.

Tecate is a minor full service POE located approximately 40 miles east of San Diego and serving rural San Diego County. The port provides service for pedestrians, passenger vehicles, commercial vehicles, and rail (the rail line crosses at Campo, located east of the port). It currently includes² two northbound commercial lanes. It connects with California SR 188, a 2-mile road providing access to SR 94.

Finally, the POE at **San Ysidro** in San Diego County (which connects directly to I-5) is not intended for commercial vehicle traffic, but does have a commercial rail line operation. The San Ysidro rail yard is being expanded to increase storage capacity from 100 cars to 196 cars. This expansion will accommodate a two-fold increase in crossborder rail capacity from 10,000 carloads per year to 19,600 carloads per year. Similarly, this allows the region to accommodate up to four trains per day.

2.1.1.2 Roadway Network

In 2012, over 93 million tons of goods, valued at almost \$170 billion, were transported in San Diego by trucks. There are three major north-south corridors handling goods movement in San Diego County: I-5, I-805, and I-15. In addition, a toll road, SR 125, connects to the Otay Mesa POE via SR 905 to other major corridors. These routes carry significant volumes of truck traffic through San Diego County and further north to Orange and Riverside counties. San Diego has one major east-west freeway, I-8, connecting San Diego County with Imperial County, to SR 94, and continuing east toward Arizona.

² Source: U.S. Customs and Border Protection. NOTE: The number of available lanes depends on operating hours and staffing, including use of commercial lanes as passenger lanes before commercial cargo lane operating hours.

Figure 2.1: Major Truck Routes in the Gateway Region

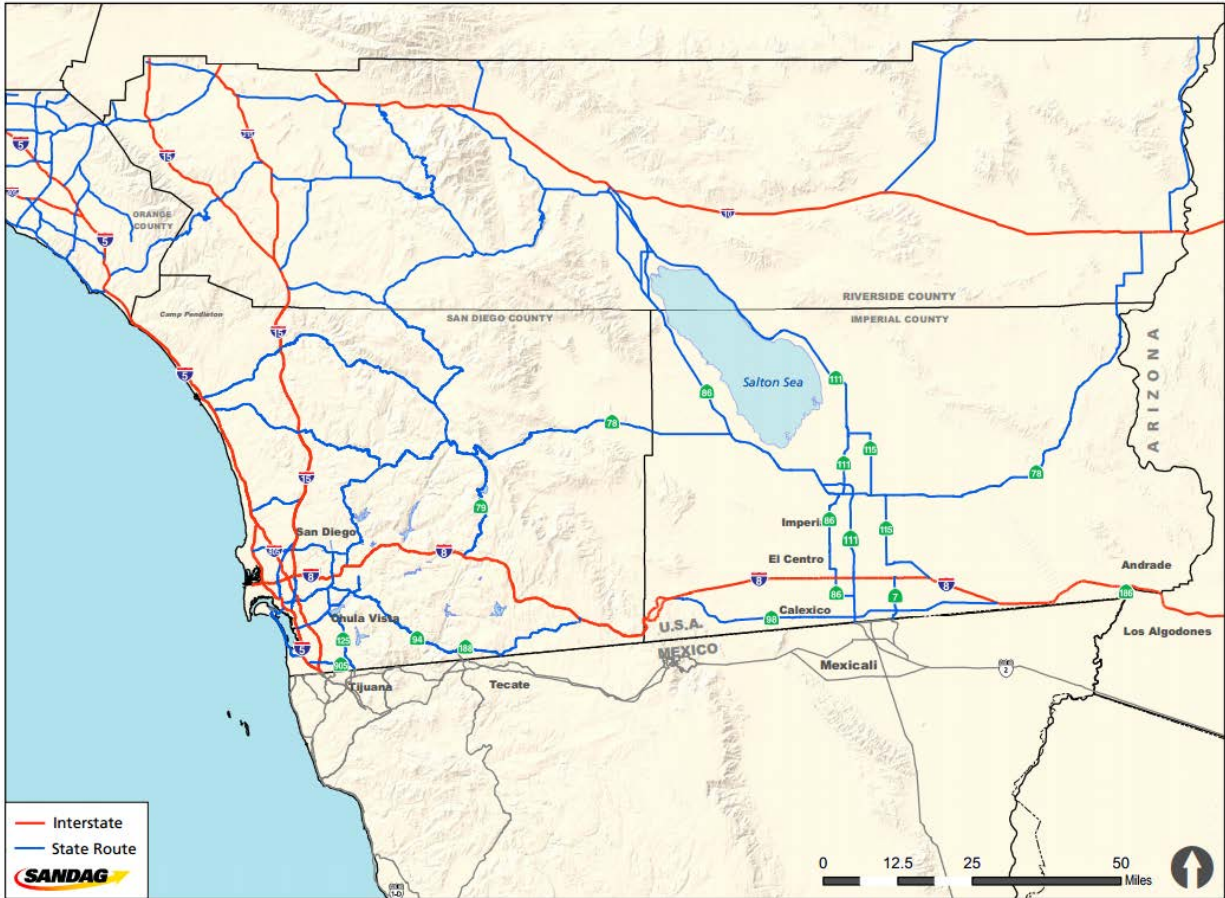

Major Truck Routes in the Gateway Region

In general, the east-west corridors are not as prominent for freight movement as the north-south freeways. The importance of the north-south corridors stems from their connectivity to major POEs along the county's southern border with Mexico as well as connectivity to the Ports of Los Angeles/Long Beach and major commercial warehousing in Los Angeles and the Inland Empire.

As a result, truck traffic³ is highest on the I-5, I-15, and I-805 corridors. Both I-5 and I-15 are unique in that they each contain a diverging point where truck traffic lessens. For I-5 this occurs at the I-805 merge, and for I-15, this occurs at the SR 163 merge. I-8 provides access for freight to central San Diego, while SR 905 is the primary connection between San Diego, Los Angeles, and the Inland Empire to the Otay Mesa POE for trade with Mexico.

³ The freight analysis in this Comprehensive Freight Gateway Study Update is based upon freight tons, derived truckloads, total trade value, and trade value per ton, not average annual daily vehicle traffic data from Caltrans.

2.1.1.3 Gaps in Existing Road Infrastructure

The lack of roadway capacity across the region is illustrated by the increase in the Texas Transportation Institute's (TTI) travel time index⁴ for San Diego, which increased from 1.04 in 1982 to 1.23 in 1997 and to 1.37 by 2007. However, since the onset of the Great Recession, this index fell to 1.13 at the end of 2012. For trucking, San Diego congestion was estimated by TTI to have imposed costs of \$314 million on the industry in 2011 from over 4 million hours of delay to trucks that year. While the limited investment in roadway capacity across the region (as measured by freeway lane-miles relative to vehicle miles traveled) is a contributing factor to recurring congestion and longer travel time, demand side pressures are also significant due to population growth and increases in trade.

Some of the more noticeable gaps and constraints in the San Diego County system include the following:

- Severely congested local roads around the Otay Mesa POE
- Lack of a direct freeway connection between the Port of San Diego Marine Terminals at Tenth Avenue Marine Terminal (TAMT) and National City, placing pressure on Harbor Drive as the main truck connection to both marine terminals
- Lack of direct freeway connections to the airport cargo terminal (San Diego International Airport)
- Lack of direct freeway connections to rail yards and intermodal facilities
- Lack of dedicated truck lanes, passing lanes, and truck bypass routes across the region
- Segments of I-5, I-805, and I-15 in San Diego County experience high levels of truck traffic at certain peak periods
- The highway system is integral to freight distribution because the region has constrained freight capacity on rail systems for terminal growth. Overall, the freight rail system in the region is highly utilized and capacity loss at terminals or on the mainline cannot be tolerated
- Extremely high land use costs throughout the county, but especially around the working waterfront coupled with no land use protections for freight-related infrastructure, inhibit freight-related investments

2.1.2 Rail Infrastructure

Rail carries a smaller percentage of total regional freight than trucks, but the rail yards and mainline infrastructure are both important and strategic. Our analysis indicates that in 2012, the value of freight transported by rail in the region amounted to less than 2 percent of overall freight flows; while this sounds like a small percentage, it is an important portion of rail traffic that both "de-congests" the region's highways and keeps the Port of San Diego competitive, especially for the automobile traffic moving through the Port. Existing rail services include Burlington Northern Santa Fe (BNSF) Railway's automotive and "manifest" trains from San Diego to the north, and San Diego County and Imperial Valley (SD&IV) short line trains from San Diego to the south and the east.

⁴ Source: 2012 Urban Mobility Report from Texas A & M University's Texas Transportation Institute at mobility.tamu.edu/ums/report/.

2.1.2.1 Existing Rail Lines and Ports of Entry

San Diego County is served by several rail companies that own and/or operate rail facilities within the county.

In the northern part of the county along the I-5 corridor, BNSF Railway operates a line owned by North County Transit District (NCTD) and Metropolitan Transit System (MTS), which connects Santa Fe Depot in Downtown San Diego with the Orange County line to the north. Specifically, BNSF operates on the segment of the system from Oceanside to Downtown San Diego and to the National City Marine Terminal (NCMT) (this segment also is owned by BNSF). Pacific Sun Railroad operates on the NCTD line between Oceanside and Escondido, and the Miramar branch.

In the southern portion of the county, SD&IV Railroad, a subsidiary of Genesee & Wyoming Inc., operates two short lines on track both owned and shared with MTS. One line connects the Santa Fe Depot in Downtown San Diego with the San Ysidro border crossing and freight yard; another with the City of Santee, to the east.

Additionally, the Baja California Railroad (BJRR) owns the rights to operate limited service between the Mexican border at San Ysidro/Tijuana through Mexico to Division (near the Mexican border at Tecate). The section between Tijuana and Tecate is owned by the Mexican government. Pacific Imperial Railroad (PIR) has operating rights from Division and on to Plaster City in the western part of Imperial County. The section between Division and Plaster City is owned by MTS. However, the portion between Division and Plaster City is currently closed due to bridge repairs.

Figure 2.2: Rail Lines in the Gateway Region

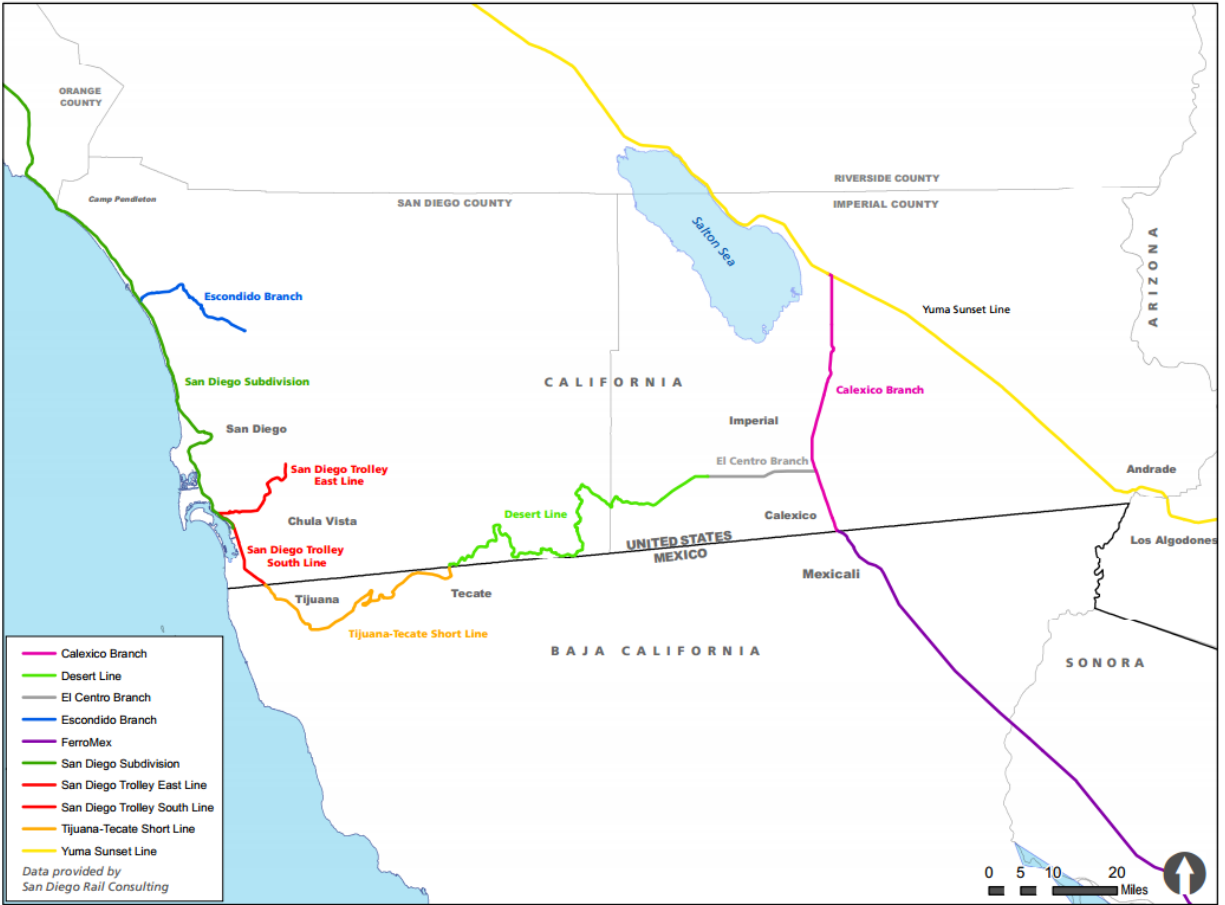

Rail Lines in the Gateway Region

Figure 2.3: Gateway Region Rail Line Ownership Map

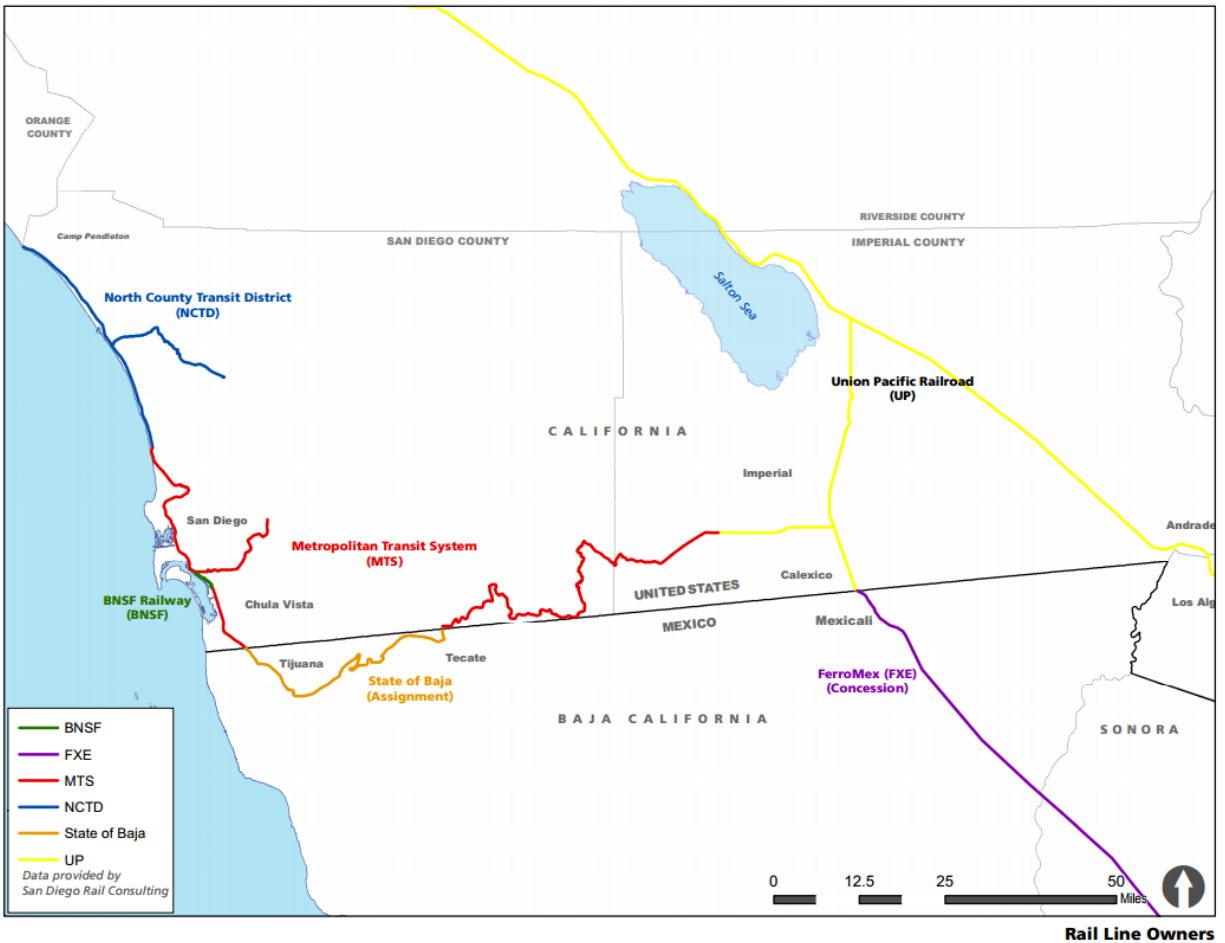
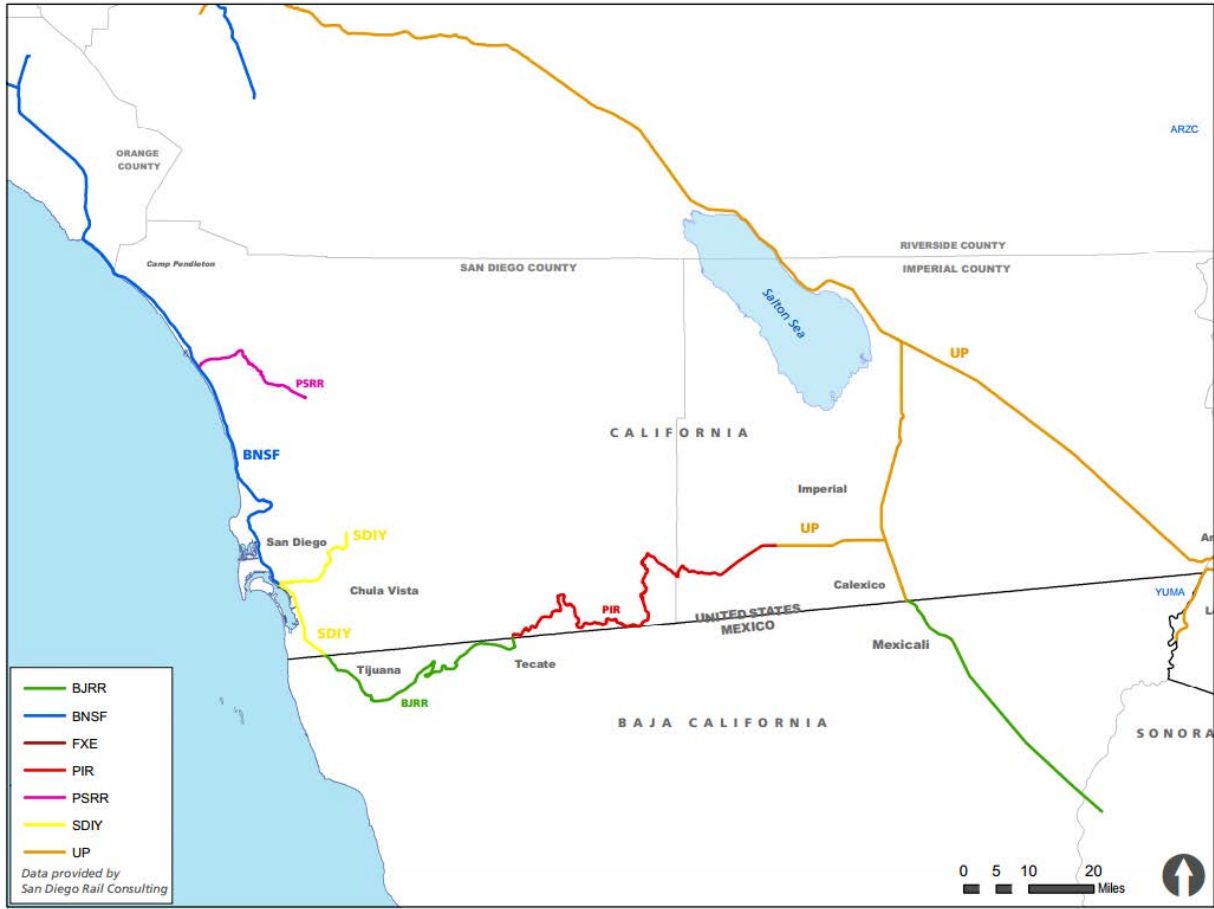

Figure 2.4: Gateway Region Rail Line Operators Map



San Diego and Imperial County Rail Operators

2.1.2.2 Gaps in Existing Rail Infrastructure

Freight trains in San Diego County move along corridors shared with multiple transit agencies. Thus, BNSF freight trains share the heavily utilized Los Angeles to San Diego (LOSSAN) Corridor with commuter rail COASTER and Metrolink and with intercity passenger rail operated by Amtrak. BNSF also shares tracks with light rail service SPRINTER between Oceanside and Escondido. Similarly, SD&IV freight trains share the South Line, from Downtown San Diego to San Ysidro, with Trolley commuter services operated by MTS.

The dual use of tracks, often in very congested urban areas with limited ability to lay new tracks, is a major constraint on existing operations and a challenge for future growth. Freight rail service on the South Line, for example, is currently restricted by federal regulations to two trains operating each night within a window specified by San Diego Trolley, Inc. Furthermore, this operating window is often impacted by routine maintenance activities.

Although there are projects planned to increase mainline throughput, carload capacity is primarily limited by the capacity of the rail yards. The BNSF San Diego rail yard has an estimated manifest cargo capacity of around 1.75 million tons per year, while auto handling capacity is estimated at 500 thousand tons per year. In terms of crossborder rail movement, current capacity is estimated at about 1.6 million tons per year.

To summarize, a number of gaps – or deficiencies – within the existing system are evident. They include:

- Non-dedicated freight rail lines on MTS-owned facilities from Downtown San Diego to the Mexican border and to the City of Santee, resulting in short operating windows which limit freight rail car throughput
- Non-dedicated freight rail lines on NCTD-owned facilities from mid-county San Diego to the Orange County border resulting in short operating windows which limit freight rail car throughput
- Single track sections for freight on the LOSSAN corridor
- Limited roadway access to the San Ysidro rail yard facilities to stage trains near the Mexican border at San Ysidro

Proposed rail improvements in the county could improve the performance of the network in the short-term. These proposed projects include:

- Increasing storage capacity at the San Ysidro yard (project in progress)
- Double tracking bottlenecked areas served currently by single track in the LOSSAN Corridor (some projects planned, others in progress)

2.1.3 Seaport Infrastructure

2.1.3.1 Existing Seaport Infrastructure

The San Diego Unified Port District is located approximately 10 miles from the Mexican border and is the first port in the United States for vessels sailing north from the west coasts of Mexico, and Central and South America.

The port's activity is split between Tenth Avenue Marine Terminal (TAMT) and National City Marine Terminal (NCMT), both located within the San Diego Bay. The port is designated by the Department of Defense as a strategic port, which may be called upon to support military activities.

TAMT is a 96-acre cargo complex located near Downtown San Diego, south of the Convention Center and north of the San Diego-Coronado Bay Bridge. It houses 23 acres of warehouses and transit sheds and eight berths, with another 25 acres of paved open space for lay down of steel and project cargo. Tenants at TAMT handle containerized and break-bulk fruit, dry bulk cargos including sand and cement, petroleum products, and various break-bulk and project cargos. The theoretical maximum capacity of TAMT is approximately 4.9 million metric tons per year.

Figure 2.5: Tenth Avenue Marine Terminal

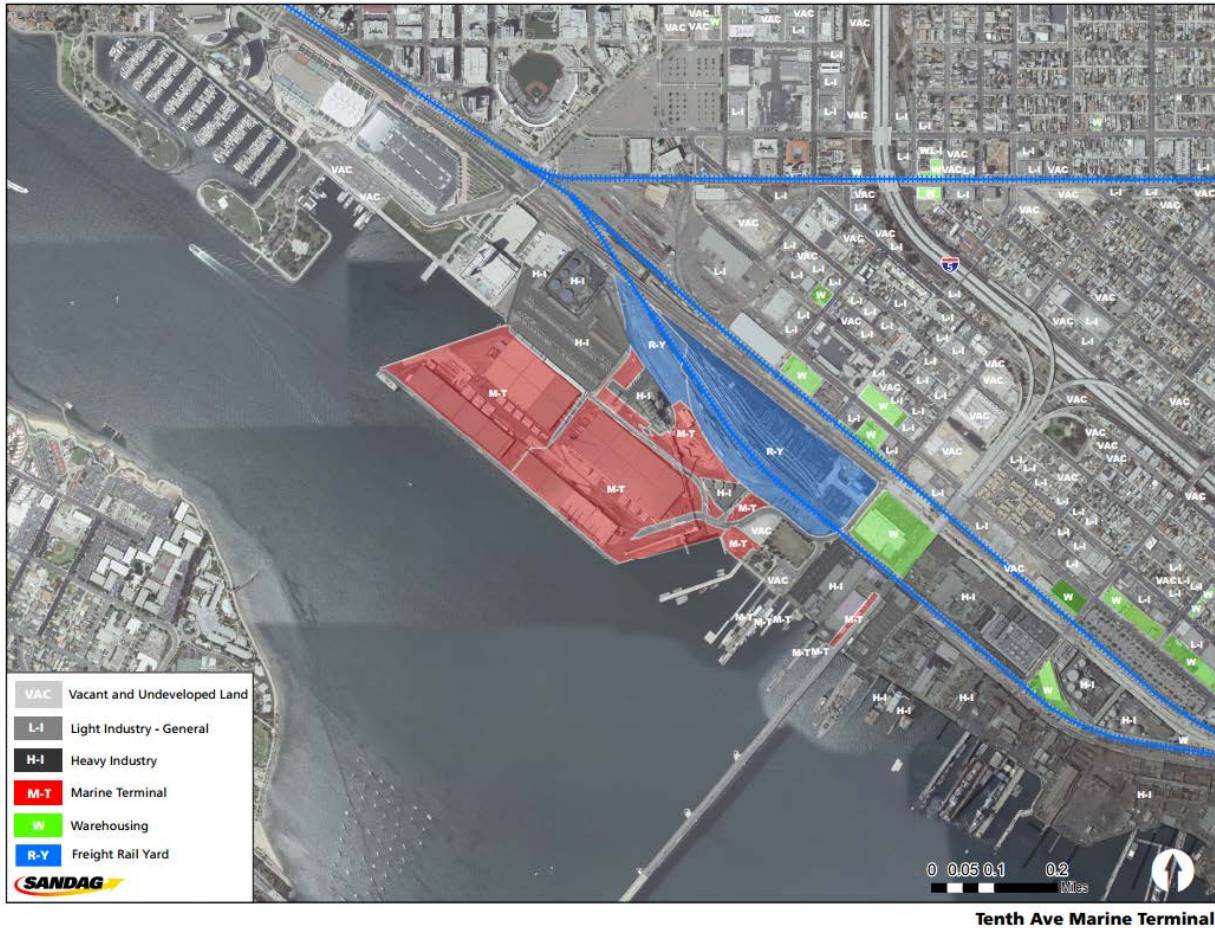

NCMT is further inside San Diego Bay, south of TAMT and approximately ten nautical miles from the harbor entrance. The terminal is located at the end of Bay Marina Drive in the City of National City. It covers 125 acres and houses eight berths. Lumber and automobiles are the primary cargos currently moving through NCMT.

Figure 2.6: National City Marine Terminal



Goods move in and out of the port by road or by rail. TAMT and NCMT both have on site rail. TAMT rail assets are owned and maintained by the Port of San Diego, rail assets at NCMT are owned by the Port of San Diego, but maintained by the railroad. All rail services to and from the two terminals are operated by BNSF.

California SR 15 and I-5 are in close proximity of the TAMT and NCMT. California SR 54 and SR 94 are also near the port, but are rarely used as long-haul trucking routes.

Figure 2.7: Transportation Network Serving TAMT and NCMT

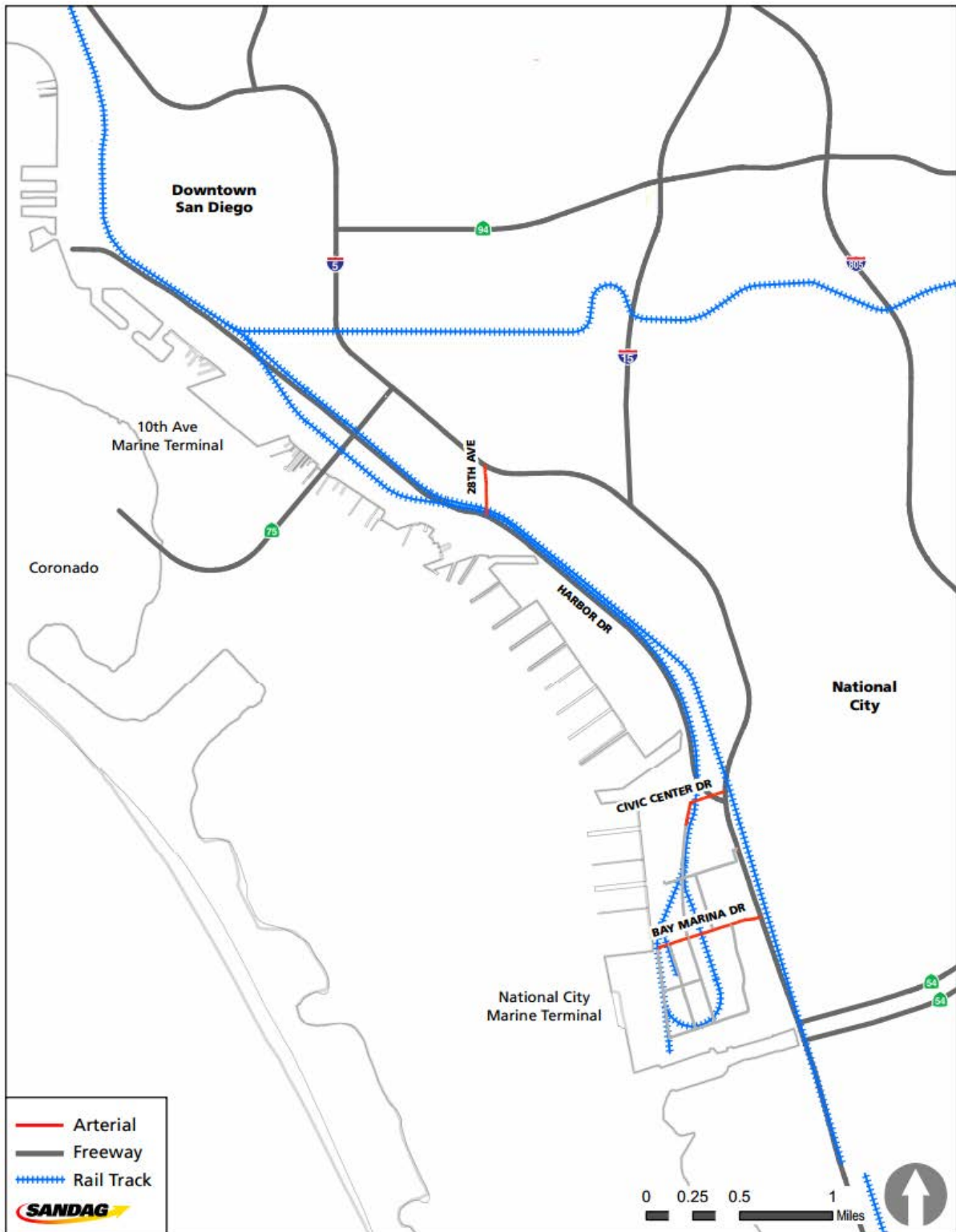

Transportation Network Serving TAMT and NCMT

2.1.3.2 Gaps in Existing Seaport Infrastructure

Although the San Diego Unified Port District is currently updating master plans for TAMT and NCMT, there are still a few gaps in the current infrastructure. According to the 2008 Port Business Plan Update, some of the most noticeable gaps include:

- Need for improved freeway access to existing marine terminals (partially addressed by completed port access improvements at 10th Avenue, Civic Center, and Bay Marina intersections)
- Improvements to Harbor Drive, which could balance and optimize automobile and commercial vehicle usage
- Insufficient open-air storage area and underutilized covered storage buildings at TAMT
- Additional TAMT terminal optimization strategies are needed to facilitate higher throughput levels at TAMT

2.1.4 Airport Infrastructure

2.1.4.1 Existing Airport Infrastructure

The San Diego International Airport, also known as Lindbergh Field, is located in the northwest portion of the downtown area, within the City of San Diego. The airport is bounded by North Harbor Drive and San Diego Bay to the south, the Navy water channel and Liberty Station to the west, the Marine Corps Recruit Depot to the north, and Pacific Highway and I-5 to the east. Land in the vicinity of the airport is densely developed and has high developable value, making any future airport expansion unlikely. The Figure below shows an Aerial photograph of the San Diego International Airport facilities.

Figure 2.8: San Diego International Airport, Lindbergh Field



With just 661 acres, the San Diego International Airport is the smallest “major airport” site in the United States. It features a single 9,401-foot long east-west runway supported by one full-length parallel taxiway on the south, and one partial-length parallel taxiway on the north. It is the busiest single runway commercial airport in the country. There are currently two main terminals, serving domestic and international passengers. Most support facilities are located north of the runway. They include general aviation facilities, air cargo facilities, related aviation support facilities and aircraft rescue and firefighting facilities. The current Airport Master Plan (2008) identifies 69,750 square feet of air cargo buildings on airport property.

The cargo facilities are used by a limited number of operators, including commercial airlines, courier services, a single cargo company (Capital International Cargo), and the U.S. Postal Service (U.S.P.S.). The airport handled 162,353 tons of cargo and mail in 2013. The all-cargo carriers currently operate out of portable trailers next to the north cargo ramp. Cargo is trucked in and out of the airport, with sorting and loading performed offsite. The majority of cargo flights are by the major freight-only (integrated) carriers Federal Express (FedEx) and United Parcel Service (UPS).

Air cargo operations are “constrained” due to limited space for expansion, as the airport is located in the downtown area. The airport is attempting to improve operations within the space constraints, including rehabilitation/reconstruction of the cargo apron by 2016. San Diego had been seeking to relocate the airport for over two decades, but now improvements are being implemented at the current location.

Regional access to the airport is provided by I-5 and I-8 (interstate access is in close proximity to the airport, but there is no direct freeway access to or from the airport). Approximately 66 percent of traffic accesses the airport via the interstates, with 34 percent accessing to/from I-5 South, 17 percent to/from I-5 North, and 15 percent to/from I-8 East. The remaining 34 percent of airport traffic accesses the airport via local streets with 22 percent heading south along North Harbor Drive, Pacific Highway, and Kettner Boulevard. I-5 runs adjacent to the north side of the airport and access to and from I-5 is provided from Grape and Hawthorne streets to the south and Laurel/India streets and Pacific Highway to the north. I-5 provides access to the local streets that bound the airport: North Harbor Drive to the south, which provides access to the terminal facilities, Pacific Highway to the northeast, which provides access to facilities in the north, and Rosecrans Street to the west.

2.1.4.2 Gaps in Existing Airport Infrastructure

Constrained by its urban core location, the San Diego International Airport faces many challenges to providing adequate goods movement through the region. Air cargo capacity used in this analysis is based on the Destination Lindbergh Study, which estimated current cargo capacity at just over 157 thousand tons. The Destination Lindbergh Study also identifies the following deficiencies:

- Lindbergh Field has a unique runway that accommodates both passenger and cargo services; clearly passenger demand is likely to command the most capacity and will soon reach the limits of the single runway
- Limited warehousing space: UPS, U.S.P.S., and DHL all currently sort cargo off site, and FedEx sorts cargo onsite at the terminal

The inherently constrained footprint of Lindbergh Field is contributing to air cargo deficiencies. Planned short-term air infrastructure improvements include the development of an Intermodal Transportation Center on the north side of the airport (with direct access to the airport via I-5) as well as additional warehousing space and the air cargo parking apron.

2.1.5 Warehousing Infrastructure

San Diego County has three major districts that house significant warehousing facilities: Miramar - Sorrento Mesa, the Port District, and the Otay Mesa area. Of these three locations, two are directly served by rail (Miramar and the Port District) although the service is limited and direct connectivity is an issue to the Port of San Diego at the TAMT.

TAMT has 300,000 square feet of refrigeration and cold storage facilities. The terminal also has roughly 32.5 acres of open-air storage, which are currently occupied by Dole Fresh Fruit Company. NCMT has 174 acres of open air storage for lumber and automobiles. It also has over 800,000 square feet of storage for dry and refrigerated cargos.

The Otay Mesa POE has bonded warehouses and Foreign-Trade Zone warehouses that permit in-bond merchandise (i.e., merchandise considered to be under Customs jurisdiction because it has not entered U.S. commerce) to be stored, transferred, manipulated, and/or destroyed. These bonded facilities are closely tied to the maquiladora (or twin-plant) industry in Mexico. Trucks originating from - or destined for - the Otay Mesa border area move materials, intermediate goods, and finished products between assembly plants in Mexico and storage or repackaging facilities in the San Diego region as well as to destinations outside the county.

The Otay Mesa industrial submarket has 334 buildings with a total of 15,332,299 square feet and is the fourth largest industrial area in the county. As of the 4th Quarter 2014, there were 1,647,468 square feet/10.7 percent vacant. 2014 net absorption was 698,120 square feet, which has outpaced all other industrial submarkets in the county.⁵

⁵ CoStar

Figure 2.9: Warehousing Facilities in the Otay Mesa Border Crossing Area

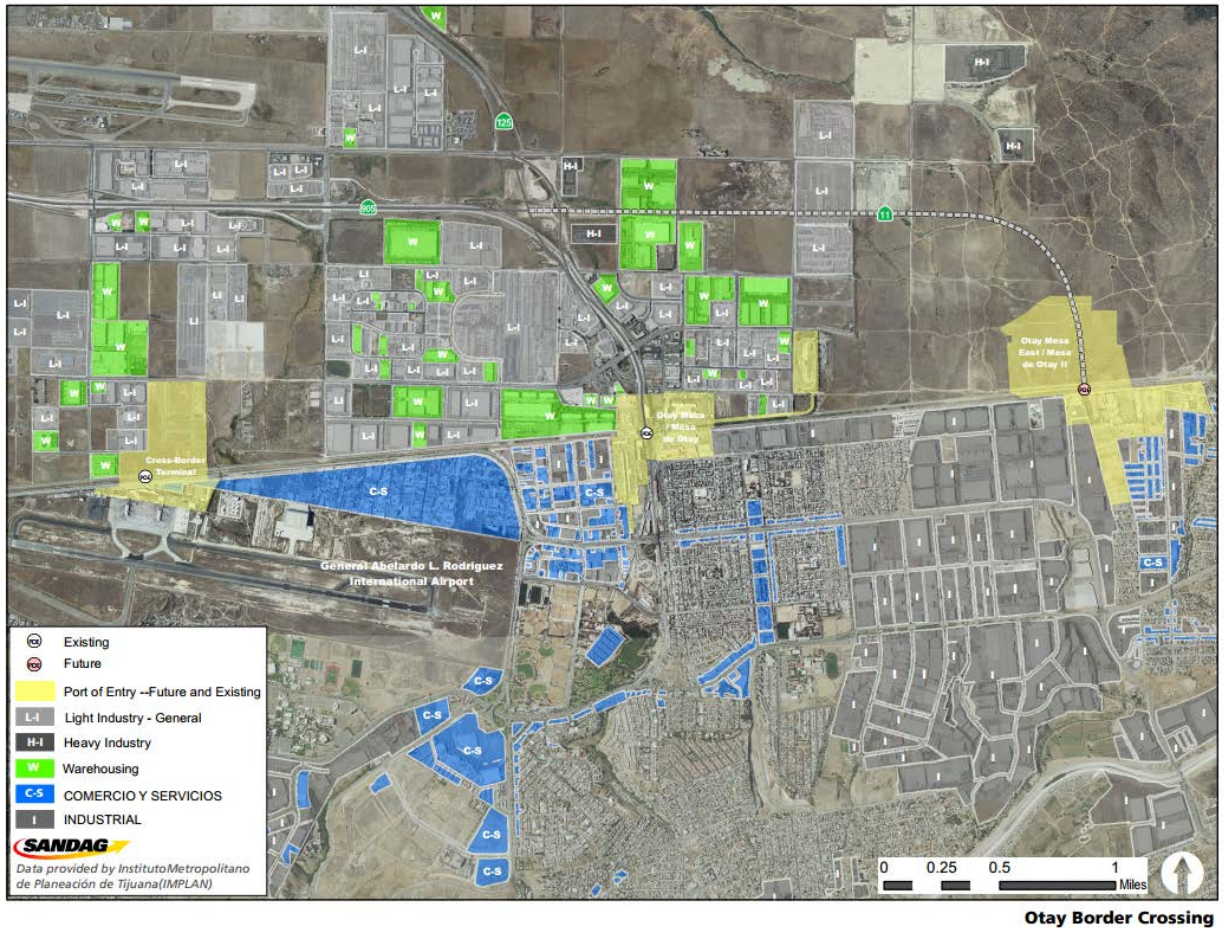

2.1.6 Pipeline System

There are two pipelines in San Diego, the Kinder Morgan Santa Fe Pacific Pipeline, L.P. (formerly SFPP, LP) for gasoline and aviation fuel, and the WestPac Pipelines, LLL, (formerly Buckeye Petroleum) pipeline for aviation fuel.

The Kinder-Morgan pipeline system (in Figure below) extends south from the Los Angeles Basin through Orange County into San Diego, and also extends into Imperial County to serve the Naval Air Facility in El Centro.

The major Kinder-Morgan terminals are located in Mission Valley (which supplies the majority of the gasoline for San Diego County) and Imperial County. These terminals are the facilities where gasoline is blended and then loaded onto trucks for final distribution to service stations. The pipeline extends to central San Diego to supply the Chevron and Tesoro Logistics distribution terminals.

The 4.3-mile WestPac pipeline system extends from the TAMT to Lindbergh Field and supplies aviation fuel for the airport. WestPac has a sublease from the Jankovich Company, and receives aviation fuel from the Kinder-Morgan pipeline.

Figure 2.10: Pipeline System in Southern California



Source: Kinder Morgan Santa Fe Pacific Pipeline, L.P.

Figure 2.11: Pipeline System in San Diego County

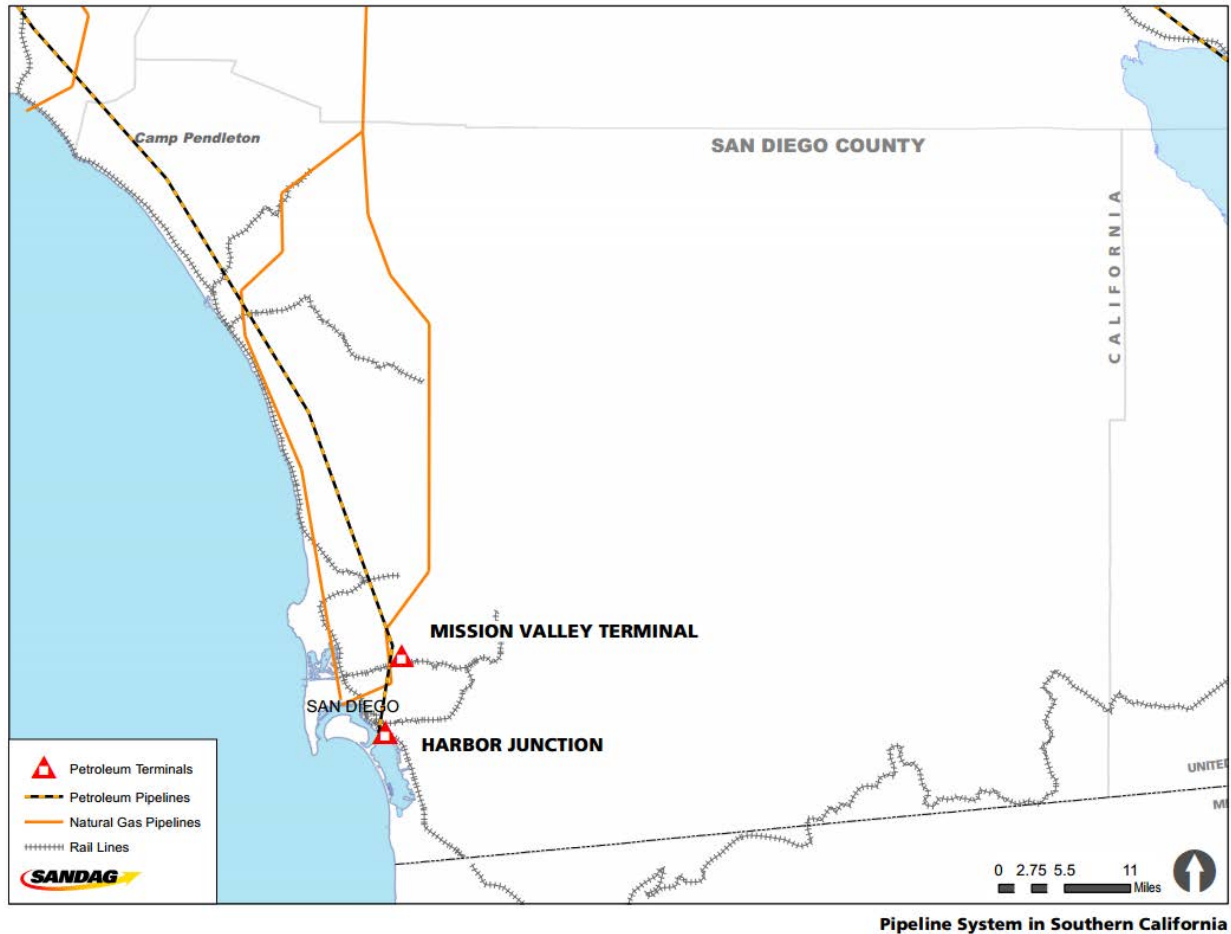

2.2 Imperial County Freight Infrastructure

2.2.1 Road Network and Ports of Entry

Imperial County has a well-developed roadway network which serves interregional, intraregional and interstate travel for autos, commercial vehicles and recreational vehicles. Recent population growth and an increase in foreign trade will require infrastructure improvements in order to accommodate future demand projections. The highway system currently handles over 95 percent of all commodity flows across the county.

The county is connected to Mexico through three (land) Ports of Entry (POEs): Calexico West, Calexico East, and Andrade.2.2.1.1 Ports of Entry

2.2.2 Calexico West/Mexicali I POE

The Calexico West/Mexicali I POE is located in the City of Calexico and is the primary port for daily person crossings into the United States by car or as pedestrians. This POE is the third busiest Land Port of Entry in California with 4 million northbound vehicles crossing each year, 4.8 million northbound pedestrians crossing each year, and it is the critical economic engine for Imperial and Mexicali region.

The Imperial-Mexicali region is pursuing a major renovation and expansion of United States and Mexico federal inspection operations. The Federal government has appropriated \$98 million for Phase I of the Calexico West POE Modernization and Expansion Project. Phase I includes ten northbound vehicle inspection lanes, the headhouse, and a bridge for southbound vehicle lanes. The U.S. General Services Administration (GSA) has scheduled the completion of Phase I for January 2018. Schedule for Phase II is contingent pending fund authorization from Congress.

2.2.3 Calexico East/Mexicali II POE

The Calexico East/Mexicali II POE is a passenger and commercial port located seven miles east of the Calexico West POE. The Calexico East port is the principal gateway for trade by truck through Imperial County and Baja California, Mexico. It is located roughly 130 miles east of San Diego and 60 miles west of Yuma, Arizona. The port includes eight passenger lanes, four pedestrian lanes, three commercial lanes, one FAST (Free and Secure Trade Program) lane, one bus lane, one SENTRI (Secure Electronic Network for Travelers Rapid Inspection) lane and one Ready lane that requires users to present Radio Frequency Identification (RFID) enabled cards. The FAST program allows U.S./Canada and U.S./Mexico partnering importers expedited release for qualifying commercial shipments. SENTRI cards are Western Hemisphere Travel Initiative (WHTI) compliant documents for entry into the United States by land or sea, and also provide expedited travel to approved members between the United States and Mexico Border. The Calexico East/Mexicali II POE is served by California SR-7, with direct connection to Interstate 8, about five miles to the north. Mexico is California's highest ranking trade partner and Imperial County processes an estimated 30 percent of this trade through its land POEs at Calexico East and Calexico West. In 2013, the Calexico East POE accommodated over 325,690 incoming trucks, transporting goods valued at \$13.1 billion (\$5.7 billion in exports and \$7.4 billion in imports). Previous origin and destination surveys by Caltrans estimates that 79 percent of these cross-border goods have origins and destinations throughout California and 21 percent to and from other U.S. states, Asia, Canada, Europe, and South America.

A planned improvement is the expansion of the Calexico East POE - The proposed binational toll pilot project will double the Commercial Vehicle inspection lanes from three to six lanes; expand the bridge over the All- American Canal (international boundary); and six additional passenger lanes.

The Andrade/Algodones POE is an important gateway for tourism between California and Baja California. This gateway is used primarily by pedestrians from the United States wishing to shop or use medical services in Algodones. The port also accommodates privately owned vehicles, buses, and recreational vehicles. Vehicular access to I-8, two miles to the north, is provided by SR-186.

2.2.3.1 Roadway Network

In 2012, over \$7.5 billion in goods were moved by trucks crossing through the international border with Mexico (source: BTS). An additional \$2 billion in agricultural goods was transported via the state highways and local arterials within Imperial County to destinations across the United States. (source: Farm Bureau)

There are several north-south corridors handling goods movement in Imperial County: SR-7, SR-111 and portions of SR-78 and SR-86. Along with the east-west routes of I-8 and SR-98, these highways provide connections to the Calexico East POE which is the primary processor of all commercial truck traffic in Imperial County. These routes carry significant volumes of truck traffic through Imperial County and further north to Riverside and San Bernardino counties.

There are a series of connecting freeways and conventional highways which serve the goods movement industries, maquiladora operations and multi-billion dollar agricultural sectors in Imperial County. They are outlined below.

Interstate-8 is an east-west interstate highway facility beginning in San Diego County and extending 172 miles eastward to the California-Arizona State Line near Yuma, Arizona. I-8 continues into Arizona until it intersects with I-10 near Casa Grande, Arizona. Within Imperial County I-8 spans a distance of approximately 79 miles. There are two travel lanes in each direction throughout the Imperial County region. I-8 serves regional, cross border, and interstate traffic, and provides access to desert recreational areas. The segment on I-8 from Forrester Road to SR-111 is planned to be widened to a six lane freeway to accommodate increases in both auto and commercial truck traffic.

SR-98 is mostly a two-lane conventional highway, traversing the southern portion of Imperial Valley. The 56.9 mile route follows an east-west alignment through Imperial County parallel to I-8 and the U.S / Mexico International Border. SR-98 serves as an alternate route to I-8, and provides access to many agricultural areas in the eastern part of the region. It is also an important component for cross border traffic. Improvements are underway on the section of SR-98 near Calexico to accommodate the increases in traffic as a result of the expansion and renovation of the Calexico West POE. To the east, SR-98 is proposed to be widened to a six-lane facility and/or replaced with an off-system route (Jasper Road) which would then serve as the improved truck access route to the Calexico East POE.

SR-78 Within Imperial County SR-78 is 81.8 miles in length and extends from the San Diego County line to the north junction of SR-86. SR-78 is typically a two-lane conventional highway; although the recently completed "Brawley Bypass" is a four lane conventional/expressway highway and serves to move truck traffic out of the County and to markets in the Inland Empire and beyond to the Los Angeles/Long Beach Seaports. A similar project the "Westmorland Bypass" is proposed to relocate the State Highway to the south of its existing alignment to alleviate conflicts between local traffic in Westmorland and truck traffic passing through the City to various destinations.

SR-86 is a north-south State highway facility serving Imperial and Riverside Counties. SR-86 begins at SR-111 near the U.S./Mexico International Border, and extends 90.8 miles northward (roughly parallel to SR-111) along the western shore of the Salton Sea, terminating at Avenue 46 in the City of Indio. This route is currently under study for relinquishment to the various jurisdictions; with the City of Imperial currently involved with final negotiations for relinquishment. As such, the portions

of this route within the urbanized areas does not handle extensive interregional truck traffic. However, from the junction of SR-78 (Brawley Bypass) and north, SR-86 serves as a major truck corridor connecting to the Inland Empire and the Seaports of Los Angeles and Long Beach.

SR-111 begins at the U.S./Mexico POE in the City of Calexico and continues north 103.8 miles to the City of Indio in Riverside County. SR-111 then turns westerly and extends another 41 miles to its terminus at I-10 north of Palm Springs. From the Calexico West POE to SR-98, SR-111 functions primarily as a city street and provides access to many local businesses. The existing congestion of this four-lane segment is projected to increase as the number of border crossings grows. North of SR-98, SR-111 is constructed as a four-lane expressway to the I-8 interchange. North of the I-8 interchange, SR-111 is constructed as a four-lane conventional highway. SR-111 ultimately connects with I-10 in Riverside County, which provides access to Los Angeles to the west, and Arizona to the east. From SR-98 to I-8, SR-111 has been identified as needing to be widened from four to six lanes with interchanges at three major intersections. This improvement will facilitate the continued increases in goods movement travelling across the U.S./Mexico border.

SR-7 is a north-south route from the Calexico East POE to I-8, covering a distance of approximately 6.7 miles. SR-7 is constructed as a four-lane highway with access control at the Calexico East POE, SR-98 and direct access to I-8. Extension of SR-7 to the intersection with Evan Hewes Highway is a planned improvement for this route.

SR-115 is primarily a north-south route covering a distance of 33.6 miles. SR-115 begins at the junction with I-8 east of Holtville, and ends at the junction with SR-111 in Calipatria. It is typically constructed as a two-lane conventional highway. Widening of SR-115 from Evan Hewes Highway to the junction with SR-78 is expected to accommodate increases in commercial truck traffic in the easterly north/south corridor of the county.

SR-186 is a 2.1 mile north-south route from the Andrade POE in the easternmost portion of Imperial County connecting to the interchange with I-8. SR-186 is constructed as a two-lane conventional highway. Potential improvements include the widening of a bridge structure and interchange improvements at I-8.

Forrester Road is a key north-south arterial that runs parallel to SR-111 approximately seven miles west of SR-111. It covers approximately 30 miles from SR-98 to SR-78. It is presently constructed as a two-lane facility, and is classified as a six-lane expressway in the Imperial County Circulation Element. ADT on Forrester Road is 8,800 vehicles per day, with a significant portion of this traffic being trucks carrying agricultural products between I-8 and SR-86. A Project Study Report is being conducted by Caltrans and ICTC for the purposes of identifying alternative improvements to Forrester Road, with the ultimate potential improvements being upgrading to State Highway Standards and being incorporated into the State System.

Figure 2.12: Major Truck Routes in Imperial County

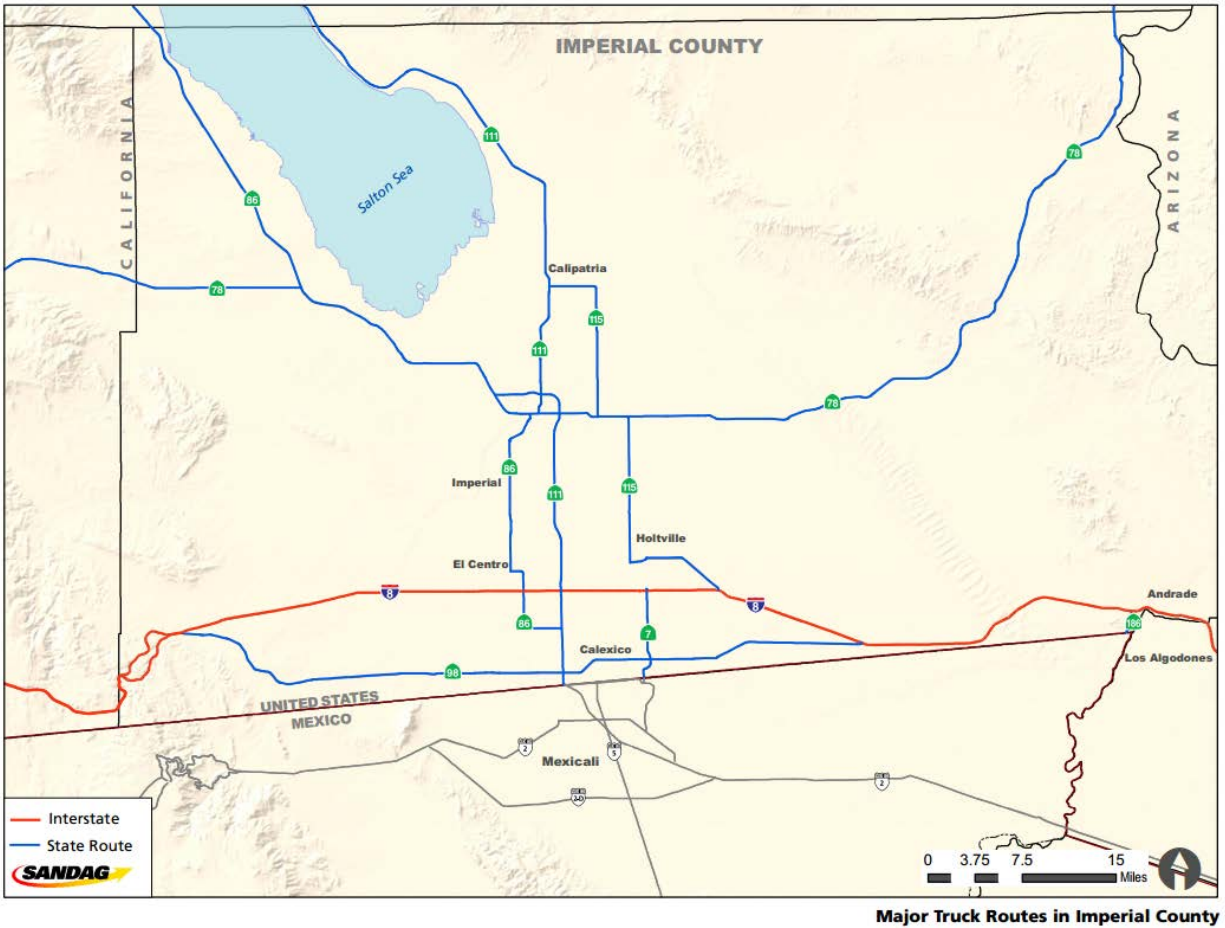

According to the Imperial County “2013 Long Range Transportation Plan”

2.2.4 Rail Infrastructure

Imperial County is served by rail connections from Mexico, Riverside County, and Arizona. Commodity flows by rail account for about 3 percent of total commodity flows in the county. This compares to 2 percent for San Diego County (and about 40% nationally).

Union Pacific Railroad (UPRR) owns and operates a line originating at the Calexico border crossing, extending north to El Centro and ultimately connecting with other UPRR tracks at Niland, heading north to Riverside County and southeast to Arizona (Sunset Line). UPRR also owns and operates the section between Plaster City and El Centro. That section is in service, and connects with other UPRR lines at El Centro. Finally, PIR owns the rights to operate on a small section of tracks in the western portion of the county between the San Diego County line and Plaster City. As noted previously, that section is closed to operations for repairs.

2.2.5 Seaport Infrastructure

Imperial County has no seaport, but the county does export products through the Ports of Los Angeles and Long Beach. Imperial County shippers and importers also utilize the San Diego Unified Port for inbound and outbound cargo shipments.

2.2.6 Airport Infrastructure

Imperial County has a small private passenger airport facility that is not capable of handling large volumes of freight. The Imperial County Airport is currently limited to air courier services such as FedEx and UPS. However, as identified in the Imperial County 2013 Long Range Transportation Plan, the county may ultimately consider development of a dedicated cargo airport. Current air cargo services in the county are provided through San Diego or airports in the Los Angeles area such as Los Angeles International Airport.

2.2.7 Warehousing Infrastructure

Imperial County has a number of warehousing facilities adjacent to the Calexico POE and near the junction of the Union Pacific railroad tracks north of El Centro at Niland.

Trucks originating from and destined for the Calexico area move goods between the Maquiladora industries located on both the United States and Mexican sides of the border at Calexico and Mexicali as well as to other destinations within Imperial County, including El Centro.

Figure 2.13: Calexico Warehousing District

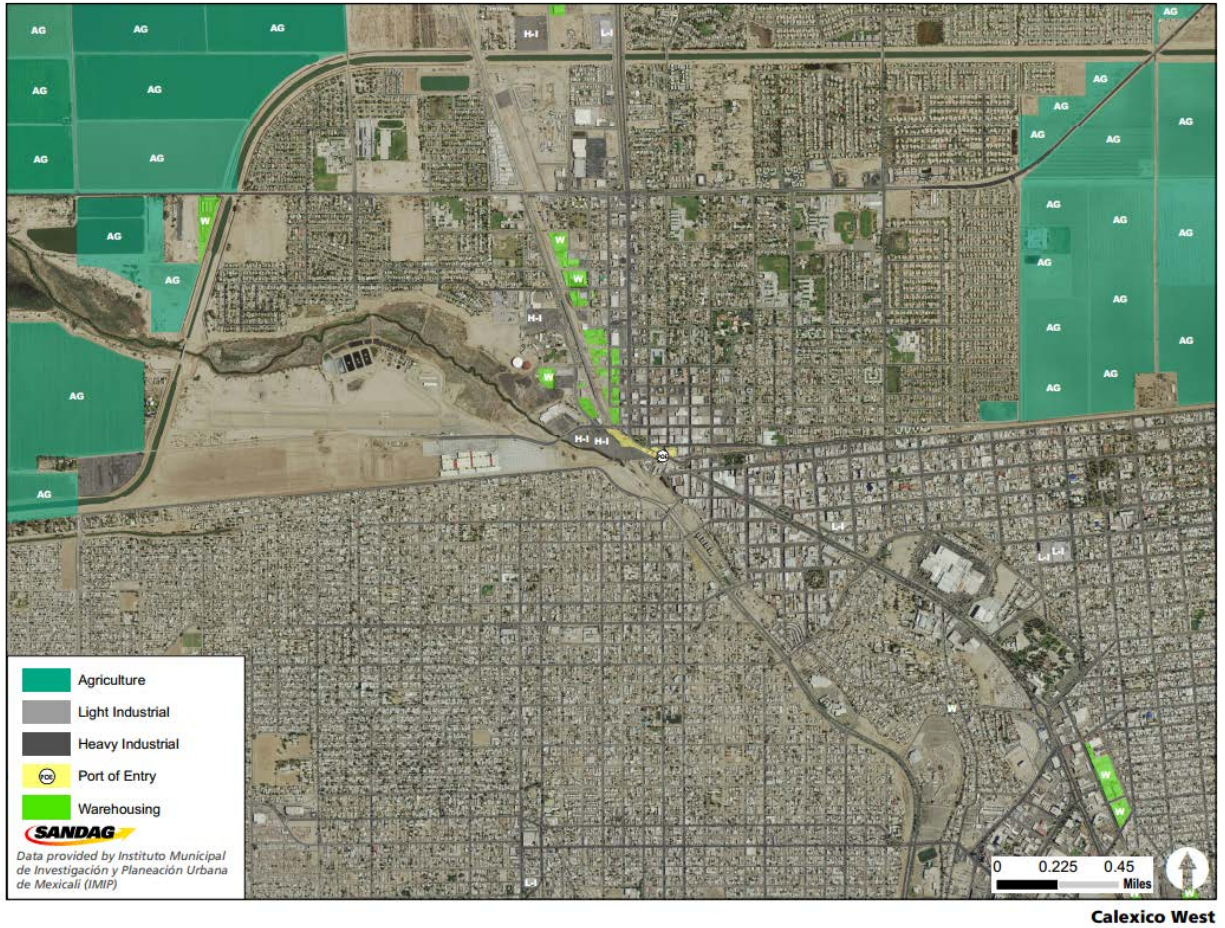
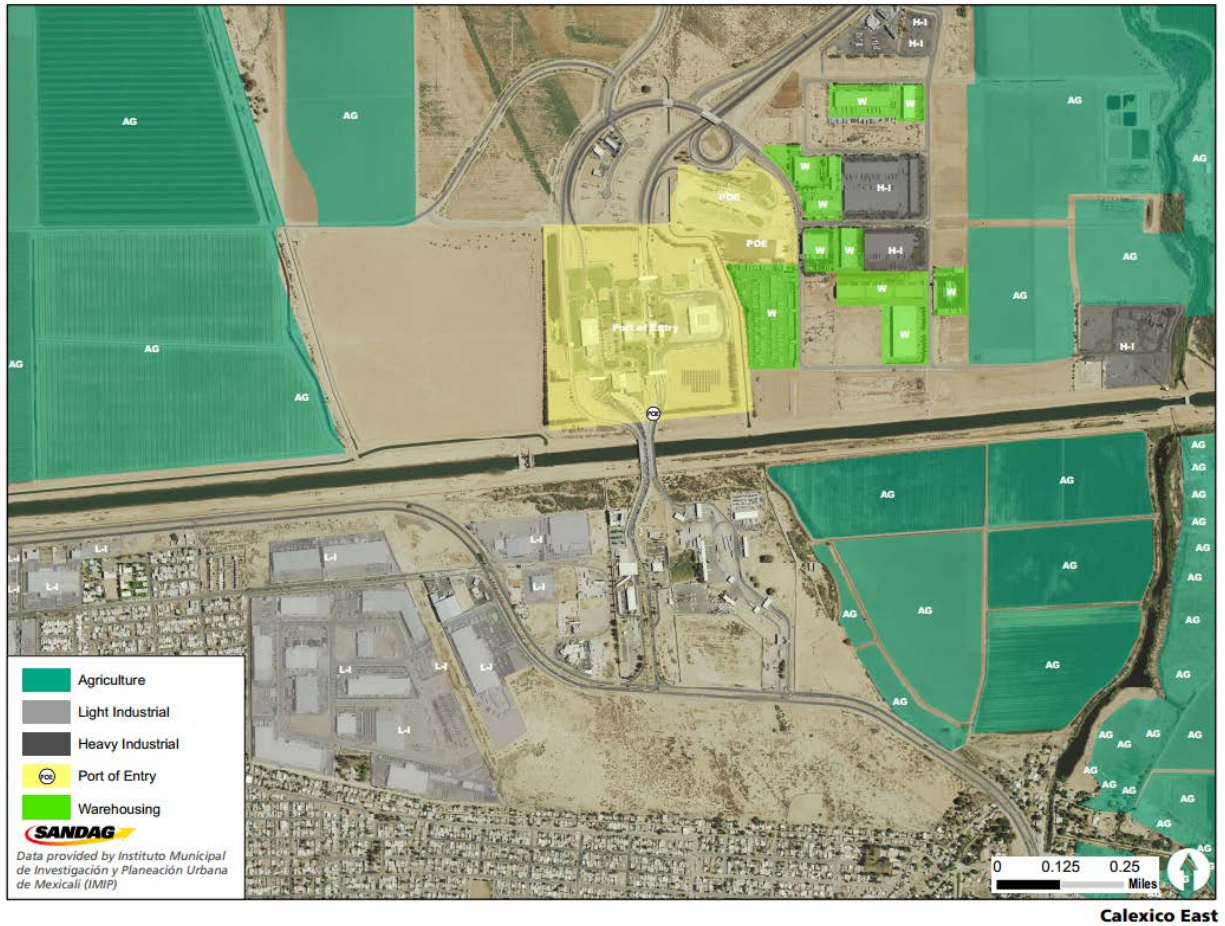

Figure 2.14: Calexico East Warehousing District



2.2.8 Pipeline Infrastructure

Imperial County has a major petroleum products pipeline extending from the Los Angeles Basin through the county to Yuma, Arizona. The main pipeline consists of a 20" diameter petroleum products pipeline from the Los Angeles Basin to Yuma, Arizona. From this main pipeline, there is also a 10" pipeline which extends southwest from a connection at Niland to a petroleum products terminal at Imperial. This pipeline also has an extension which provides aviation fuel to the El Centro Naval Air Facility. The county's pipeline system is depicted in the following Figure, as part of the Southern California Pipeline System map (repeated from section 2.1 above.)

Figure 2.15: Pipeline System in Southern California



Source: Kinder Morgan Santa Fe Pacific Pipeline, L.P.

Figure 2.16: Pipeline System in Imperial County

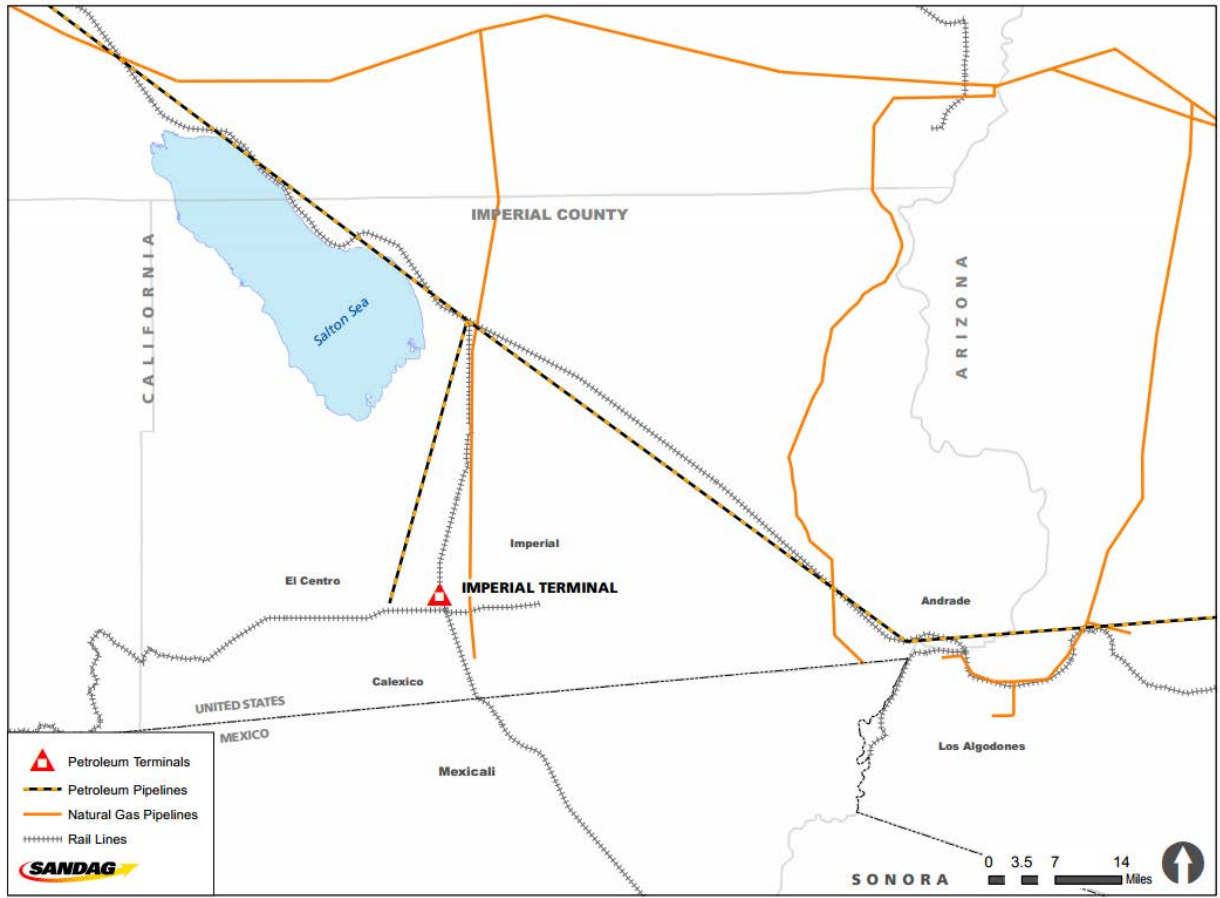

Pipeline System in Southern California

2.3 Baja California Freight Infrastructure

2.3.1 Road Network

According to Mexican state and federal transportation infrastructure agencies Secretaría de Infraestructura y Desarrollo Urbano del Estado and Secretaría de Comunicaciones y Transportes, respectively, Baja California has approximately 11,000 kilometers of major roads (“carreteras”), approximately 2,770 kilometers of which are paved, and approximately 15 percent of which are four-lane facilities. Most of the four-lane segments are concentrated in the populated areas of the state’s five municipalities (Mexicali, Tecate, Tijuana, Playas de Rosarito, and Ensenada). Major roads are typically managed under either state or federal jurisdiction.

Figure 2.17: Major Roads in Baja California

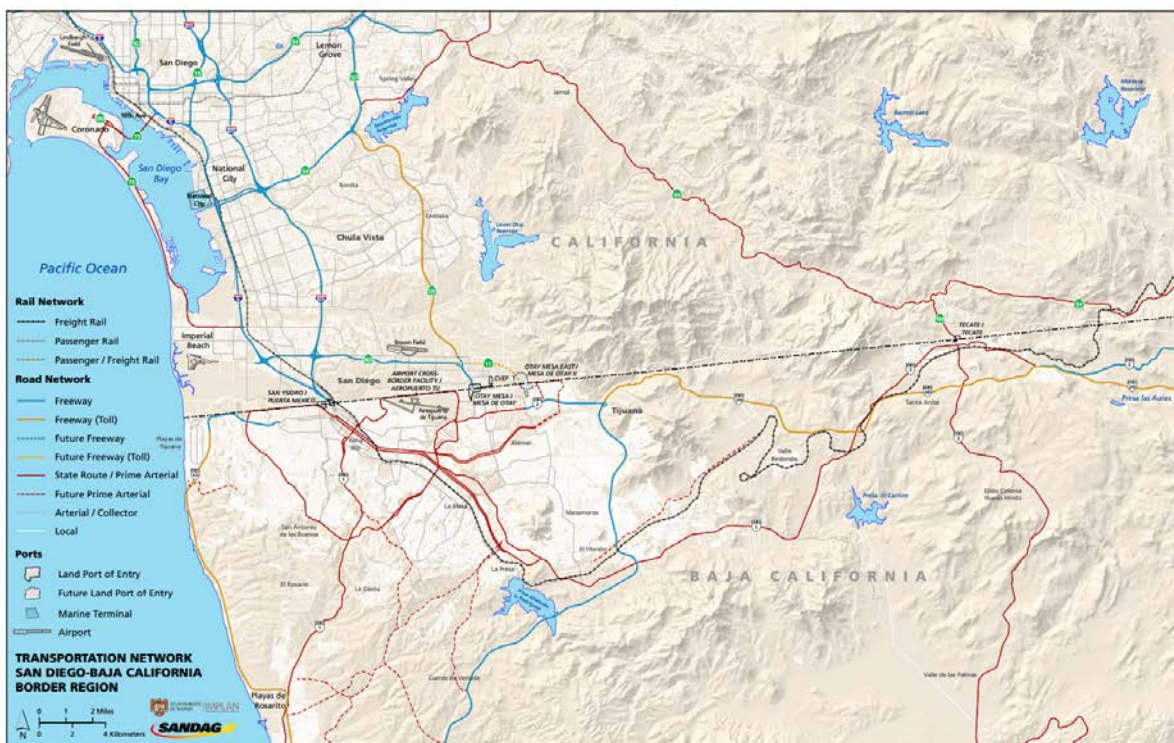

There are four major highways in the state. Highway 2 stretches east-west and connects the Tijuana, Tecate, and Mexicali POEs along the border with California. From Mexicali, Highway 2 continues east, to San Luis Rio Colorado in Sonora, and the POE there. Highway 1 runs north-south and connects Tijuana with coastal cities and the Port of Ensenada. Highways 3 and 5 also run north-south, with connections to border crossings at Tecate and Mexicali, respectively.

One of the largest road infrastructure projects completed in Baja California was the Tijuana-Rosarito Expressway or “Corredor 2000” project. This four-lane freeway runs for about 40 kilometers from East Tijuana and the Tijuana-Tecate toll road, along the southern portion of Tijuana, connecting to the Rosarito-Ensenada toll road and Popotla.

Both the state and federal governments have a variety of road infrastructure improvement projects planned, particularly to address congestion in the more-rapidly growing urban areas (Tijuana, Ensenada).

2.3.2 Rail Infrastructure

There are a total of approximately 220 kilometers of rail line in Baja California. The state is connected to the U.S. rail network at three separate crossings; one at San Ysidro, one at Division near Tecate, and one at Calexico.

Two crossings are part of the Tijuana and Tecate Short Line, which is currently administered by the State of Baja California with an operational agreement with BJRR. It connects to the SD&IV South Line in San Diego County at San Ysidro, and to the non-operating Desert Line leased to PIR, extending from Division to Plaster City in Imperial County.

Figure 2.18: Tijuana – Tecate Short Line

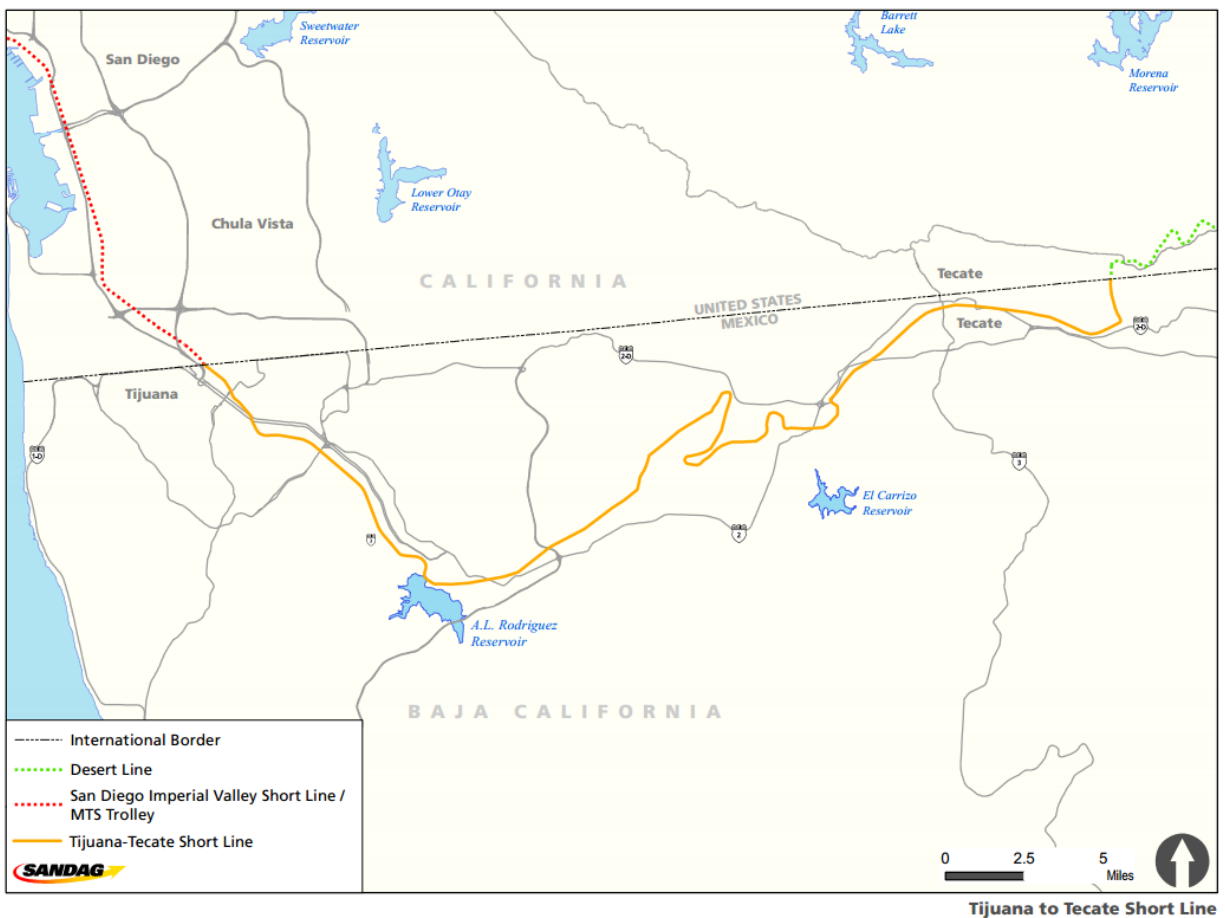

The third crossing is part of a rail line which passes through the Calexico/Mexicali POE. It extends throughout the United States via connections to Union Pacific Railroad's lines at Calexico, and throughout Mexico via connections to Ferromex lines, heading southeast out of Mexicali.

2.3.3 Seaport Infrastructure

Baja California enjoys a strategically important location for seaport infrastructure in Mexico, with a strong focus on tourism (cruise ships) and a secondary focus on commercial cargo shipping including containerized cargo, and dry bulk materials such as limestone, rock, and sand.

Baja California currently has five seaports: Puerto de Ensenada (the second-largest cruise ship destination on Mexico's Pacific Coast and the fifth busiest container port in Mexico);⁶ Puerto del Sauzal de Rodríguez (for cabotage); Puerto de Rosarito (used primarily for PEMEX-related petrochemicals); Puerto Isla de Cedros (an island off of Baja California's coast specializing in mineral exports, primarily salt); and Puerto de San Felipe (used primarily for tourism, personal boating, and fishing).

Figure 2.19: Container Ship at Puerto de Ensenada



Source: Administración Portuaria Integral de Ensenada

Future plans for Baja California ports include further expansion of existing infrastructure. The previous plans for a new seaport at Punta Colonet are on hold.

In the last decade, Puerto de Ensenada has already been expanded significantly, with the addition of a 300-meter berth and dredging to a deep draft depth of 15.5 meters (50 feet) to be able to handle post-Panamax size container ships. The port's container yard space has been increased to be able to store more containers and annual throughput capacity has been increased to 400,000 20-foot equivalent container units (TEU). The port ultimately projects a throughput capacity of up to 500,000 TEUs annually.⁷

⁶ In 2012, according to the American Association of Port Authorities, Puerto Ensenada handled over 140,000 TEUs (about 30% of which, it is estimated, related to Maquiladora shipments).

⁷ No significant near-term improvements are expected at the other four existing ports.

2.3.4 Airport Infrastructure

Airport infrastructure in Baja California comprises four main airports, only two of which (Tijuana and Mexicali) are currently able to accommodate larger aircraft.⁸

- **Tijuana – General Abelardo L. Rodriguez International Airport (TIJ):** the largest and busiest of Baja California’s airports, TIJ is located in the Mesa de Otay region of Tijuana, directly across the border from San Diego. The airport covers an area exceeding 900 acres, with a main terminal of approximately 230,000 square feet, including 23 gates and 169 commercial spaces. TIJ’s runway is 9,711 feet long, making it the largest runway in the region after Miramar. In 2013, TIJ accommodated 48,335 aircraft movements and approximately 4.3 million passengers. 15,023 tons of cargo were handled in 2011 (split almost evenly between inbound and outbound flows), representing about 85 percent of all air cargo in Baja California.⁹ A new crossborder airport facility, linking the Tijuana International Airport to San Diego is under construction and planned for opening in late 2015. A future air freight connection also is planned.

Figure 2.20: Tijuana International Airport



Source: Grupo Aeroportuario del Pacifico

- **Mexicali – General Rodolfo Sanchez Taboada International Airport (MXL):** located approximately three miles south of the border with the United States, MXL is designated as an international airport, but is only served by three Mexican airlines (with, occasionally, international charter flights and some crossborder general aviation). The entire airport property is approximately 1,400 acres, but only a small portion of this area is occupied by airport facilities (the main terminal is approximately 50,000 square feet). MXL’s runway is 8,530 feet. In 2008, the airport handled 12,450 operations, 533,800 passengers, and approximately 2,100 tons of cargo (all domestic).¹⁰ In 2013, the airport handled 496,000 passengers.
- **San Felipe – San Felipe International Airport (SFH):** significantly smaller than the previous two airports, SFH operates during limited hours (generally during daylight), and is used for general aviation and charter flights. It has an asphalt runway that is 4,850 feet long. In 2007, the airport handled approximately 6,095 operations and 14,355 passengers.

⁸ In addition to these four airports, there are also 86 smaller, less-used, and/or more-informal airstrips distributed across the state. These air strips are used by local residents, farmers, tourists, or the military (given limited road infrastructure and low density in Baja California’s rural areas).

⁹ Preliminary estimates

¹⁰ Preliminary estimates

- **Ensenada – Base Aérea El Ciprés (ESE):** the airport in Ensenada has been used primarily as a military base for the Mexican Air Force as well as for general aviation (no commercial airline currently serves the airport). Like SFH, it has an “international” designation to allow for incoming flights from the United States to check in with customs and immigration officials. Its runway is 4,892 feet long. In 2007, the airport handled approximately 7,450 operations and 13,995 passengers. No cargo is known to have passed through the airport.

Planned improvements for air cargo facilities in Baja California include the following:

- **Tijuana:** Based upon the expected near-term opening of the crossborder airport facility, the next step will be to develop and implement cargo handling operations within the facility. The air freight component is currently in the planning process.
- **Ensenada:** for several years, a private group has advocated the development of a major air cargo facility close to Ensenada. This proposal would establish a new airport – Ensenada International Airport (EIA) – outside of the City of Ensenada (and away from the current site at El Ciprés), and would be intended specifically as a cargo hub for northwest Mexico. In 2007, the Government of Mexico awarded a 30-year concession to the group to construct, administer, and operate the proposed airport. In 2009, the U.S. Trade and Development Agency funded an Airport Master Plan development study to prepare for future construction of the airport. The date of further development of this airport is unknown.

2.3.5 Warehousing Infrastructure

There is limited readily available information related to private-sector warehousing company infrastructure in Baja California. Because some industrial property has the ability to be used for warehousing as well as other industrial purposes, the definition of available warehousing space is difficult to identify for Baja California. The following is known:

- At the beginning of 2014, Jones Lang LaSalle reported¹¹ the total commercial industrial property market in Tijuana totaled 57.3 million square feet of buildings of which 4.5 million square feet was available for lease. In Mexicali, they reported a total of 1.7 million square feet with 2.4 million square feet available for lease.
- From the Instituto Nacional de Estadística y Geografía, in 2012, the transportation and warehousing sector in Baja California was \$3.9 billion, making up 5.4 percent of the economy (measured as gross state product.) There are many individual companies comprising the warehousing and transportation sector in Baja California. As of 2007, approximately 5,030 companies operated cargo and/or trucking services in Baja California, over 90 percent of which were independent, sole-proprietorships. About 340 corporations offered general cargo services; another 80 offered specialized cargo services.
- In Mexico’s 2004 Economic Census, at least 175 companies were identified as “Agencias Aduanales” (Customs Brokers) operating in Baja California. Many of these companies offered warehousing services. Another 178 companies were specifically listed as “foreign cargo trucking” companies.

¹¹ Source: Jones Lang LaSalle, Q1 2014 North American Industrial Real Estate Outlook

3 GATEWAY REGION: UNDERSTANDING THE IMPORTANCE OF TRUCK CORRIDORS

The Gateway Region freight flow update presented in this chapter provides a critical new perspective which focuses attention on the importance of truck corridors for both the San Diego and Imperial County regions. This chapter will focus on truck freight corridors by analyzing truck tonnages driven by both domestic and international activities for San Diego, and international activities for Imperial County. The chapter also will examine top commodity categories, geography of flows, and for crossborder flows, the direction of trade moving through San Diego and Imperial Counties. Domestic freight corridor and international trade corridor flows are all quantified in tonnage terms.

As discussed in the first chapter when considering the base year of 2012, the truck mode dominates overall freight tonnage in the region, whether international or domestic. Not only is truck tonnage the dominant freight mode, but it is a mode where public agencies play a critical role in understanding the importance of freight and ensuring that adequate highway infrastructure is in place. Pipeline and sea vessel modes are the significant alternative modes, although pipeline transport of large tonnage volume is limited to petroleum products moving in the region. The analysis and discussion; therefore, is primarily focused on truck flows with attention to internal-to-the-region freight flows as well as the highway and rail networks that connect the Gateway region to the rest of the United States and Mexico; it is important to understand these truck corridors and associate their importance to the region's connectivity to global supply chains.

A discussion of the approach to the analysis and data sources is presented first, followed by a domestic corridor flow summary discussion supported with figures and tables, and an international corridor summary discussion with supporting figures, tables, and maps. Illustrative supply chain vignettes follow the freight corridor flow sections in order to illustrate commodity-specific flow examples in more detail.

3.1 Updated Gateway Region Corridor Freight Flow Analysis: Approach

The approach to analyzing freight and truck corridor flows in the Gateway Border Region of San Diego and Imperial County used public sources of freight flow data, by mode of transport and geography of origin and destination with border-specific international flows which were collated for a common base year and forecast period. This truck corridor flow baseline data captures the freight activity in the region during the recent period of economic recovery after the Great Recession of 2008-2009; thereby, updating the original Gateway Border Study (finalized in 2010) with a base year of existing flows from 2007 (the end of the economic boom before the Great Recession). The approach to the truck corridor data draws upon the most widely used public sources which offer validation and acceptance for public planning purposes as well as the ability for others to replicate this process in the future with newer updates to those data sources.

Consistent with this approach, the primary source for the truck flow data used in this update is from the same source as used in the forecast flows, the U.S. Department of Transportation's (U.S. DOT) Freight Analysis Framework (FAF). For the updated estimates of existing flows, the new FAF version 4 has been used. The FAF is a national modal freight commodity database, made publicly available by the U.S. DOT and is updated annually combining data from a number of modal historic freight statistics. The commodity flows in the FAF are identified with a common classification, the Standard

Classification of Transported Goods, also used by the U.S. Census Bureau Economic Census Commodity Flow Survey, one of the key data inputs for the FAF. Transport mode for domestic freight and international trade are identified for commodities moving to, from, within, and through the United States. The import and export flows by commodity and mode are detailed by country/region trading partner, including Mexico specifically for this study update. The latest FAF historic data consistent with published FAF forecasts are for the year 2012. The version 4 of the FAF was released in March 2014. The 2012 base year data has been used for this updated Freight Gateway Study and is the basis for the summary tonnage data tables presented here.

The resulting updated truck corridor flows for the Gateway Border region now capture the influences of regional industry growth, population, and employment growth and composition of trade growth between the prior Gateway Border Study base year of 2007 and 2012.

Below is a listing of historic data sources used in the update of the Gateway Study truck corridor flows:¹

- U.S. DOT, Federal Highway Administration's Freight Analysis Framework
- Data on border crossings and crossborder freight flows from the U.S. Customs and Border Protection and U.S. DOT, Bureau of Transportation Statistics
- Port commodity tonnage data from the U.S. Army Corps of Engineers Waterborne Commerce Statistics
- San Diego International Airport statistics from the San Diego County Regional Airport Authority
- Commodity-specific data sources, including databases maintained by the County Agricultural Commissioners (statistics on agricultural production), the California Department of Resources, Recycling, and Recovery, formerly the California Integrated Waste Management Board (data on waste production from recycling centers and landfills), and pipeline companies
- Various planning documents previously prepared for and provided by SANDAG

Analysis of the truck corridor flow data also relies on the involvement of regional freight stakeholders and subject matter experts, who were consulted during the course of the update study to provide input to the use of data for the project.

3.2 Updated Key Truck Corridor Flow Analysis

The analysis of trucks moving on the interstate and highway corridors in the Gateway region is critical to understand how this fundamental network provides capacity for freight transportation activities. For truck freight, the network is made up of the key highway segments such as the interstates, state routes as well as the arterials and connector roads that trucks use to reach the freight handling facilities themselves. These include the access roads to the seaport, airport, and warehouse facilities as well as the connector roads to border Ports of Entry. As displayed in Figures 3.1 and 3.2, both San Diego and Imperial Counties have commercial and industrial clusters which necessitate trucks using an intricate roadway network.

¹ Additional detail on freight data sources used can be found in Appendix A.

Figure 3.1: Commercial and Industrial Land Uses in San Diego County/Northern Baja California

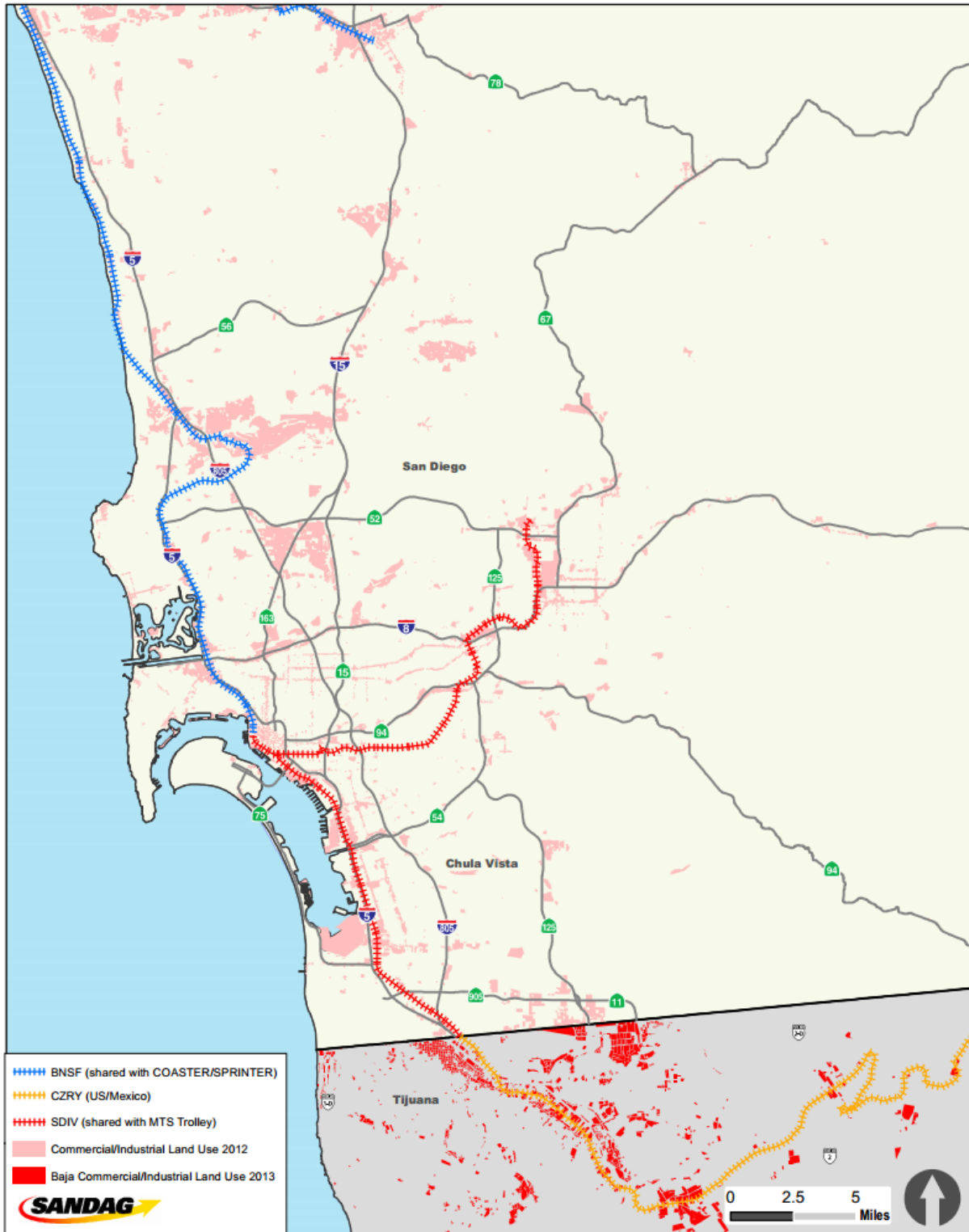

Commercial and Industrial Land Use - San Diego County

Figure 3.3: Freight Gateway Flows (in tons) in the San Diego/Imperial County Region

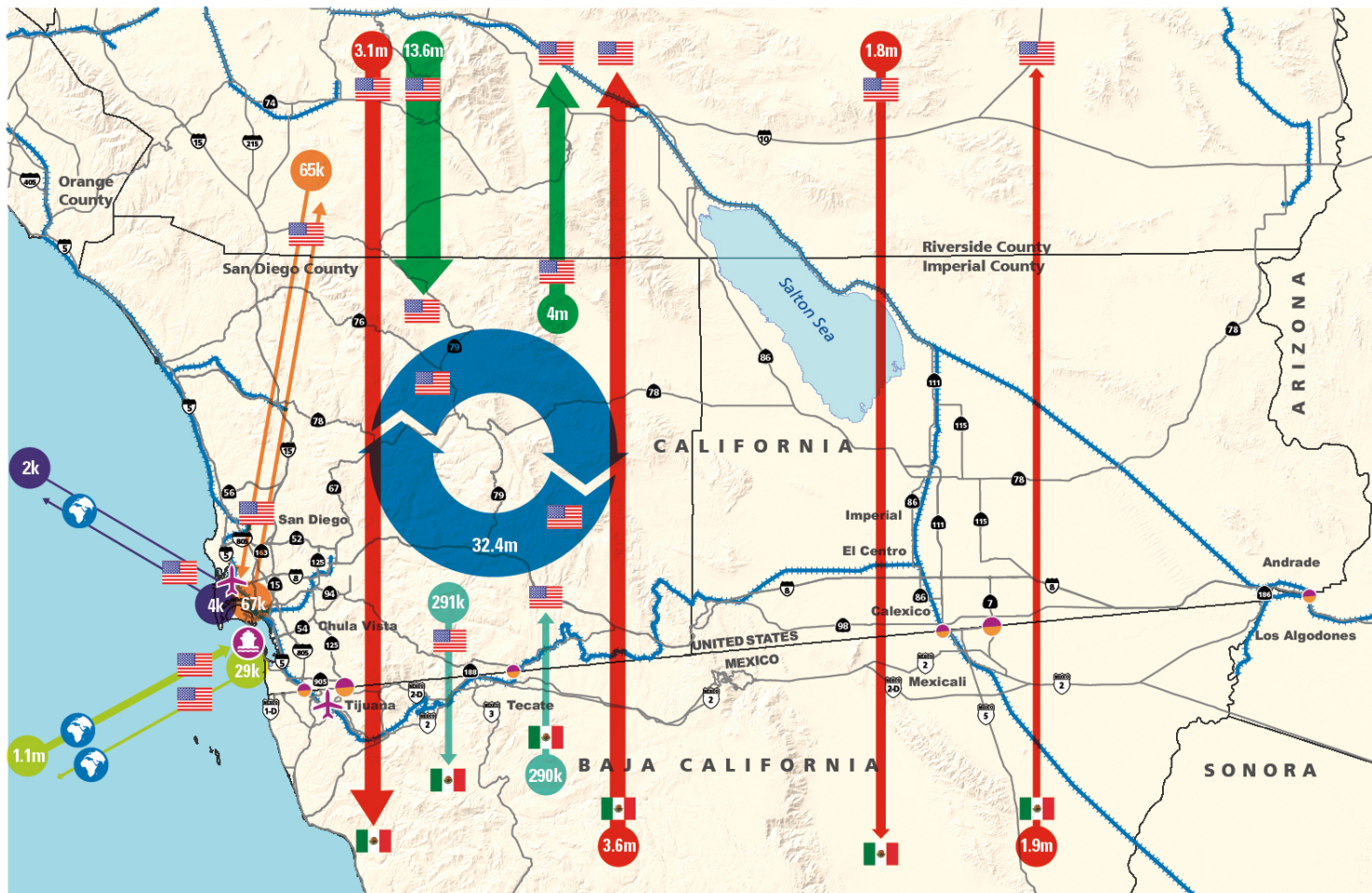

**Freight Gateway Flows:
Inbound, Internal,
and Crossborder**
November 2016



- Port of Entry
- Airplane
- Marine Port
- International
- Mexico
- United States
- Rail
- Freeway/Highway
- Tonnages in millions
- Tonnages in thousands
- Truck: Through (Mexico-US-US-Mexico)
- Truck: Intraregional (San Diego)
- Truck: Crossborder (Mexico-US-US-Mexico)
- Truck: Domestic (San Diego-US)
- Port (International)
- Airplane (International)
- Airplane (Domestic)

11/16/2016

Figure 3.4: Truck Gateway Flows (in tons) in the San Diego/Imperial County Region

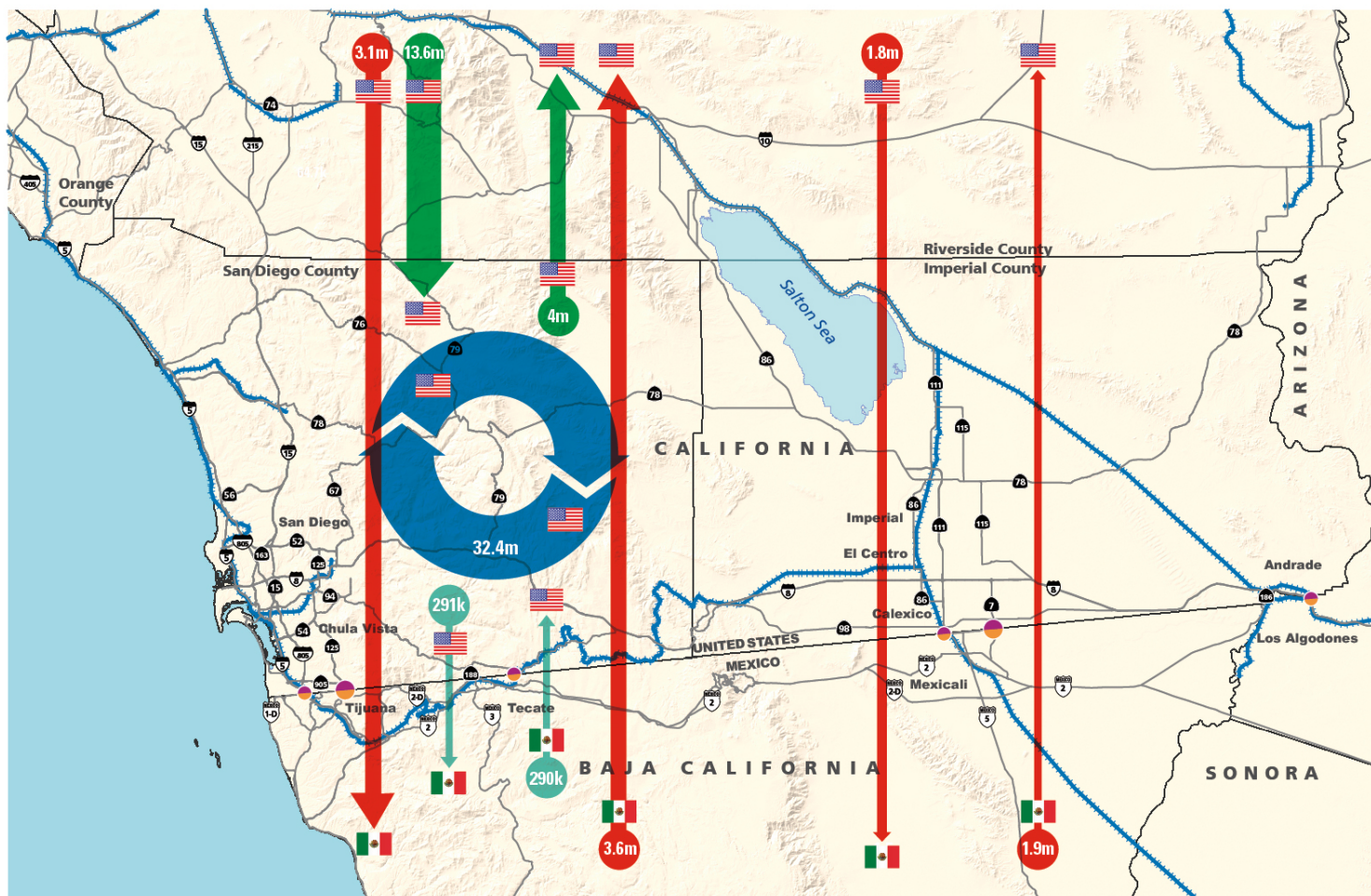

**Freight Gateway Flows:
Inbound, Internal,
and Crossborder**
November 2016



- Port of Entry
- Airport
- Marine Port
- International
- Mexico
- United States
- Rail
- Freeway/Highway
- Tonnages in millions
- Tonnages in thousands
- Truck: Through (Mexico-US-US-Mexico)
- Truck: Intraregional (San Diego)
- Truck: Crossborder (Mexico-US-US-Mexico)
- Truck: Domestic (San Diego-US)

11/16/2016

Figure 3.5: Aircraft and Marine Cargo Gateway Flows (in tons) in the San Diego County Region

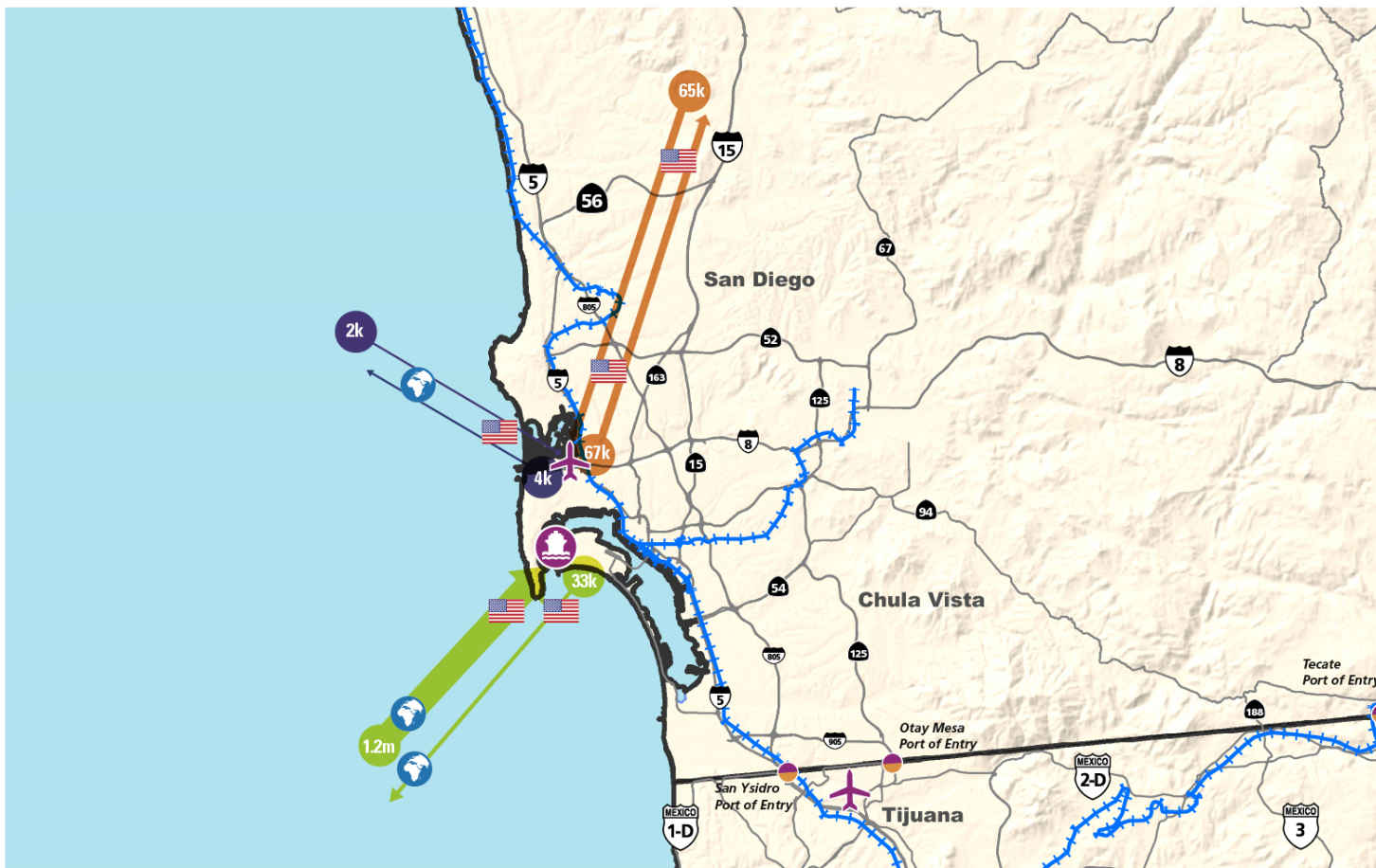

Freight Gateway Aircraft and Marine Cargo Flows
November 2016



- Port of Entry
- Airport
- Marine Port
- International
- United States
- Rail
- Freeway/Highway
- Tonnages in millions
- Tonnages in thousands
- Port (International)
- Airport (International)
- Airport (Domestic)

11/16 2086

The north-south orientation of the truck flow arrows in Figures 3.3 and 3.4 mirror the dominant origins and destinations for freight external to the region whether in Mexico to the south across the border or to the north into Riverside and on to Orange, Los Angeles, and San Bernardino counties. The large seaports of Long Beach and Los Angeles plus the extensive warehousing and intermodal rail container yards of the Inland Empire are reached to the north via the Interstate 5 (I-5) and the I-15 corridors, as illustrated in Figure 3.23. There is also freight moving to/from the east on the I-8 corridor, but the dominant flows are the north-south truck freight corridors which provide access to major east/west freight lanes.

The Port of San Diego generates a substantial volume of tonnage related to international imports. The majority of the cargo is from passenger automobiles and bananas and plantains shipped from Asia, Europe, and South America respectively.

For the San Diego International Airport, domestic air cargo accounts for the majority of cargo tonnage with a fairly even split between inbound and outbound destinations.

3.3 Domestic Freight: Corridor Discussion by Tonnage

The internal movement of trucks within San Diego itself represents the largest proportion of truck tonnage on the road network, exceeding the total of both the domestic truck freight with the rest of the United States and internationally with the border region. Domestic truck freight tonnage on the primary north/south corridors in and out of the Gateway region comprises more than two times the tonnage as the border truck region illustrated in Figure 3.6 and Table 3.1.

Figure 3.6: Truck Tons Percentage by Origin/Destination of Movement, San Diego

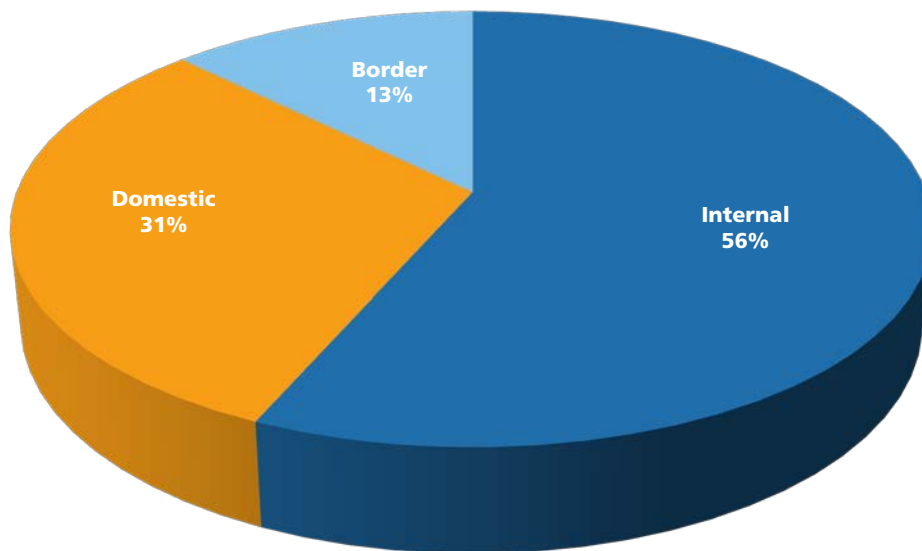

Source: FAF 4

Table 3.1: Truck Tons by Type of Movement, San Diego

Truck Flow Type	2012 Tons (thousands)
Internal²	32,444
Domestic³	17,643
Border⁴	7,244

Source: FAF 4

Figure 3.7 and Table 3.2 illustrates the truck freight flow tonnage by direction; which is another reflection of how trucks (and the tonnage they carry) utilize the region's highway network; and the nature of how truck flows serve businesses in the region including truck travel to the freight gateways in the region. Figure 3.7 is similar to Figure 3.6 in that over 32 million tons moved by truck within the region (referred to as internal moves) is the single largest category. The inbound domestic truck tonnage on the network is substantially greater than domestic outbound truck tonnage, however, through truck tonnage (defined as import and export tonnage not stopping within San Diego County) exceeds domestic outbound truck tonnage at 6.7 million tons.

Figure 3.7: Truck Tons Percentage by Direction, San Diego

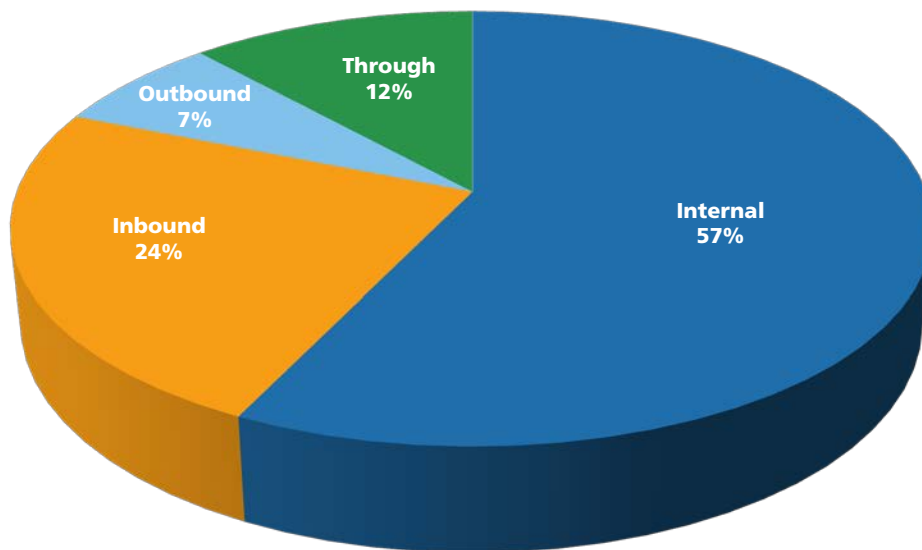

Source: FAF 4

² Internal is defined as having an O/D in San Diego County

³ Domestic is defined as having an O/D in the United States other than San Diego County

⁴ Border is defined as having an O/D through the international land POE

Table 3.2: Truck Tons by Direction, San Diego

Truck Flow Direction	2012 Tons (thousands)
Internal	32,444
Inbound	13,631
Outbound	4,012
Through	6,664

Source: FAF 4

The most significant proportion of overall truck traffic is internal truck movements (57%); secondarily inbound and outbound flows together represent 31 percent of the total truck tonnage. The fact that nearly 90 percent of regional truck flows can be attributed to trucks moving goods internally in the region or in/out of the region is an indication of the importance of the highway truck corridor connections. This is an important point because these domestic truck flows depend on how the interstates and highways connect to San Diego consumers and end markets elsewhere. Additionally, if the 31 percent inbound/outbound truck tons are combined with the 12 percent of truck tonnage moving through the region across the border, nearly 45 percent of the truck tonnage is dependent on the external freight highway corridor connections, with a substantial majority utilizing the I-5 and I-15 corridors.

Long-term growth forecasts for overall inbound and outbound freight tonnage carried by truck averages close to 1 percent per year. This rate of increase in truck freight corridor tonnage is not dramatic in the short-run, but over the long-term, this growth will require sustained attention to ensure freight corridor capacity. Alternative modal transportation options may be limited as truck demand continues to grow. Alternative capacity for the rail freight and domestic sea freight networks may not necessarily be feasible due to competing uses for valuable land that would be needed for such rail terminal or seaport terminal expansion. Nonetheless, planning for adequate future freight capacity on the rail network and at the seaport must be kept in focus. Additionally, there are competing demands for additional passenger rail service from the same shared-use regional rail track network. Space limitations on the two port terminals may present a challenge for the potential for the use of Marine Highway (formerly called Short Sea Shipping or Coastwise) services to handle north-south (I-5 or I-15) freight diverted from truck.

Figure 3.8: Inbound Domestic Freight Percentage by Mode of Transportation

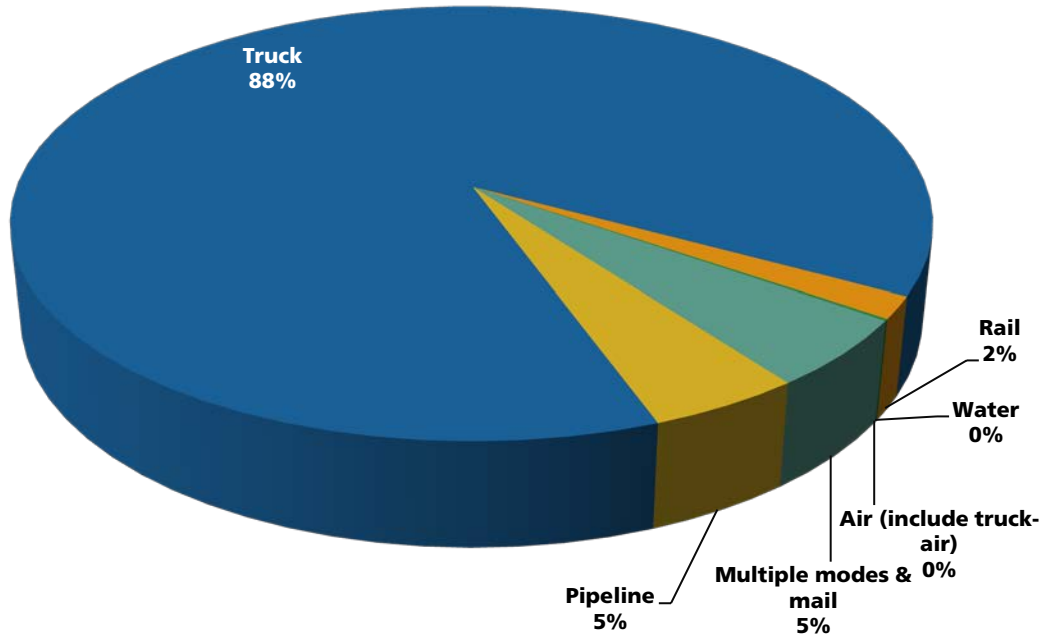

Source: FAF 4

Table 3.3: Inbound Domestic Freight by Mode of Transportation

Domestic Inbound	2012 Tons (thousands)
Truck	13,631
Multiple Modes and Mail⁵	787
Pipeline	716
Rail	254
Air (include truck-air)	20
Water⁶	0

Source: FAF 4

⁵ A Description of the FAF 4 Regional Database and how it is constructed:

⁶ Ibid.

As mentioned earlier, Figure 3.8 and Table 3.3 illustrate the dominance of truck tonnage (88%) when specifically focusing on domestic freight compared to all other modes. Total domestic inbound tonnage also has a very substantial tonnage component that is shipped through the pipeline network (5%) into San Diego from the Los Angeles Basin to the north (pipeline infrastructure is privately managed). Aside from multiple modes and mail, the inbound freight tonnage moved by the remaining individual transportation modes is less than 2 percent of the tonnage moved by truck.

Figure 3.9: Outbound Domestic Freight Percentage by Mode of Transportation

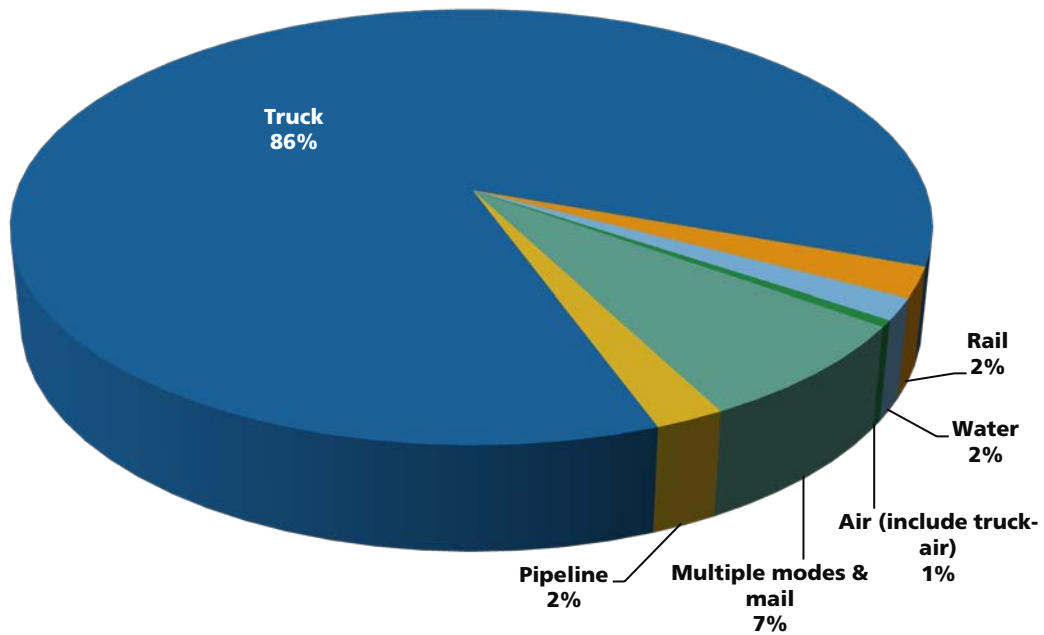

Source: FAF 4

Table 3.4: Outbound Domestic Freight by Mode of Transportation

Domestic Outbound	2012 Tons (thousands)
Truck	4,012
Multiple Modes	348
Rail	105
Pipeline	98
Water	74
Air (include truck-air)	23

Source: FAF 4

The outbound domestic freight tonnage in Figure 3.9 and Table 3.4 also is dominated by truck tonnage (86%); the slightly smaller total domestic outbound tonnage for other modes has substantial tonnage moved by multiple transportation modes, rail and water to other points in the United States outbound air domestic tonnage is greater than inbound air tonnage, reflecting the high value commodities leaving the region via air cargo (air cargo does not include U.S. mail traffic). Pipeline is much less significant in the outbound direction than inbound due to the limited origination of petroleum products within the region. As with the inbound direction, no one other mode comes close to matching the dominance of the truck mode; the other modes only account for less than 2 percent of the tonnage volume handled by truck, with the exception being multiple modes and mail at 7 percent.

Figure 3.10 and Table 3.5 examine the domestic inbound commodity composition for freight tonnage in the San Diego region. This information is useful to understand for planning purposes as the relationship to the economy and the potential for changes in the future vary by each type of commodity. Use of the interstate and highway networks for shipments also vary by different commodities, which is tied to inbound/outbound freight corridor use and internal truck flows within the Gateway region.

Figure 3.10: Inbound Domestic Freight Tons by Truck by Commodity to San Diego

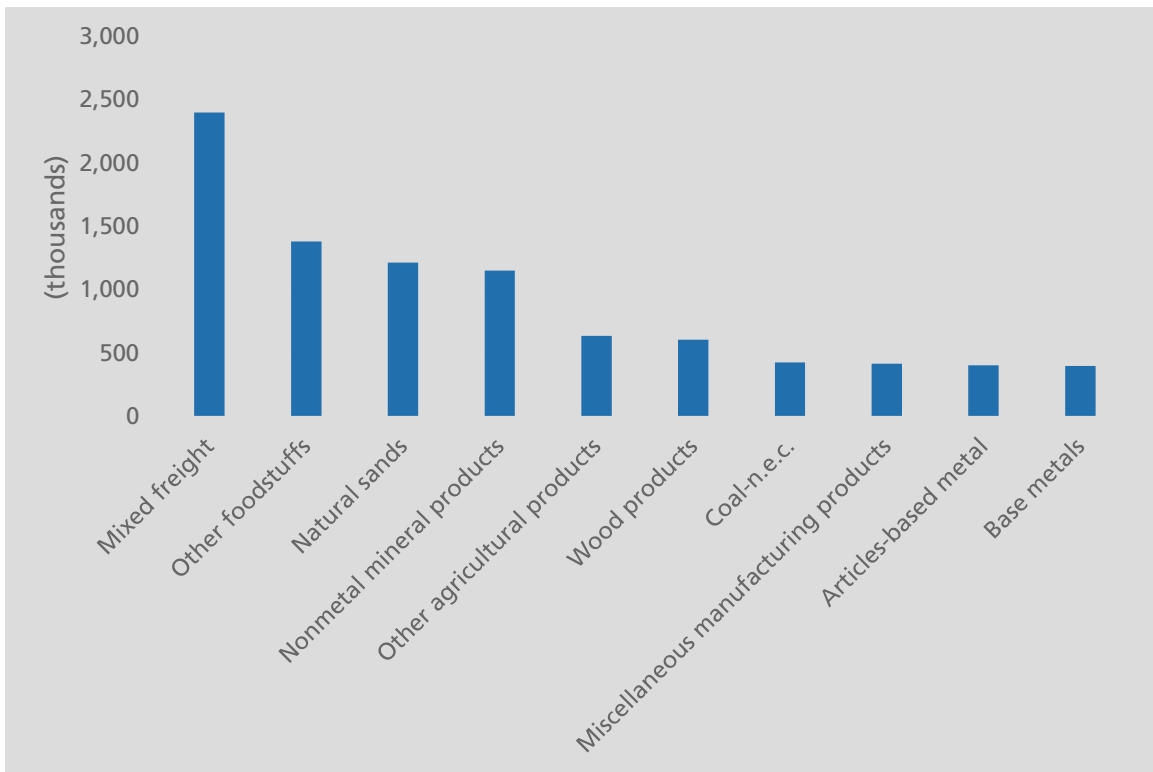

Source: FAF 4

Table 3.5: Top Inbound Domestic Commodity Flows by Truck to San Diego

Domestic Inbound	2012 Tons (thousands)
Mixed freight	2,403
Other foodstuffs	1,384
Natural sands	1,218
Nonmetal mineral products	1,155
Other agricultural products	638
Wood products	609
Coal-n.e.c.	428
Misc. Manufacturing products	418
Articles-based metal	407
Base metals	402

Source: FAF 4

From an inbound commodity shipment perspective, the mixed freight, other foodstuffs, and natural sands categories are the highest tonnage domestic commodities shipping into San Diego from elsewhere in the United States. Mixed freight and other foodstuffs includes a wide variety of goods distributed to retail stores for local consumption. The gravel and natural sands categories in Table 3.5 are commonly moved relatively short distances to construction sites where they are consumed. This is followed by nonmetal mineral products and other agricultural products. Wood products are also commonly construction materials, but given the U.S. production geography, are often shipped in from much greater distances, including rail and waterborne barge from the Pacific Northwest.

Figure 3.11: Outbound Domestic Freight Tons by Truck by Commodity to San Diego

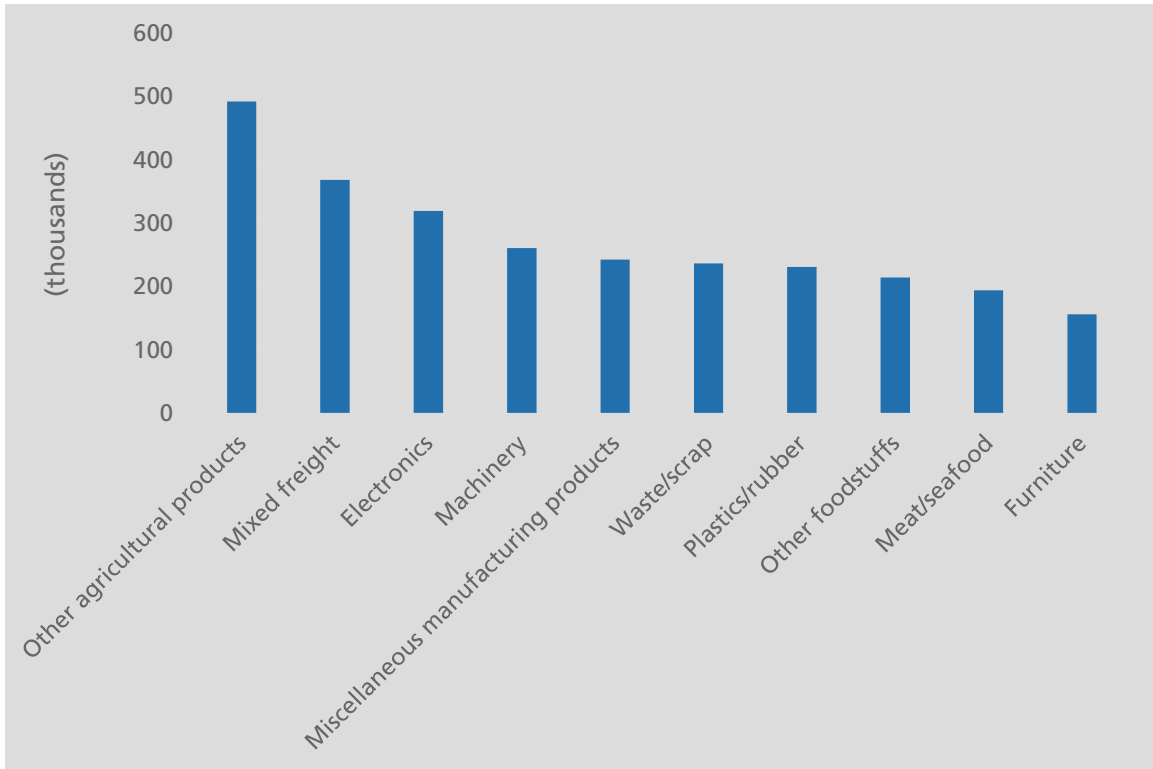

Source: FAF 4

Table 3.6: Top Outbound Domestic Commodity Flows by Truck to San Diego

Domestic Outbound	2012 Tons (thousands)
Other agricultural products	493
Mixed freight	370
Electronics	320
Machinery	262
Misc. manufacturing products	244
Waste/scrap	238
Plastics/rubber	232
Other Foodstuffs	215
Meat/seafood	195
Furniture	157

Source: FAF 4

Figure 3.11 and Table 3.6 illustrate that more domestic agricultural products are shipped out from San Diego than mixed freight. The electronics and machinery categories are the next highest tonnage domestic commodities shipping out of San Diego to elsewhere in the United States, followed by miscellaneous manufacturing products.

Figure 3.12: Inbound Origins of Domestic Flows by Truck to San Diego

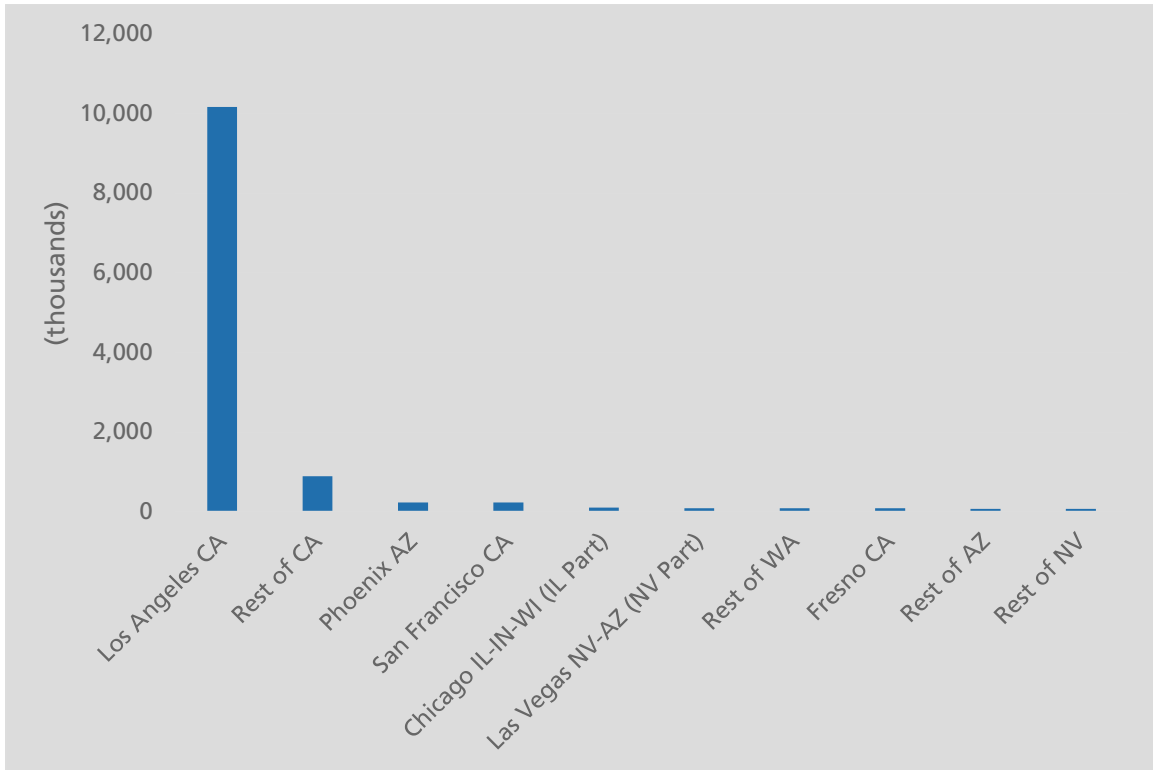

Source: FAF 4

Table 3.7: Top Inbound Origins of Domestic Flows by Truck to San Diego

Domestic Inbound	2012 Tons (thousands)
Los Angeles, CA	10,168
Rest of CA	893
Phoenix, AZ	236
San Francisco, CA	232
Chicago, IL	108
Las Vegas, NV	91
Rest of WA	88
Fresno, CA	85
Rest of AZ	71
Rest of NV	68

Source: FAF 4

Los Angeles is the largest domestic origination point for freight flowing into San Diego. The rest of California along with Phoenix and San Francisco also are ranked near the top. These origin points again clearly emphasize the importance of the I-5 and I-15 highway corridors for regional inbound flows. However, origins from the east are also important, most notably from Arizona and Nevada.

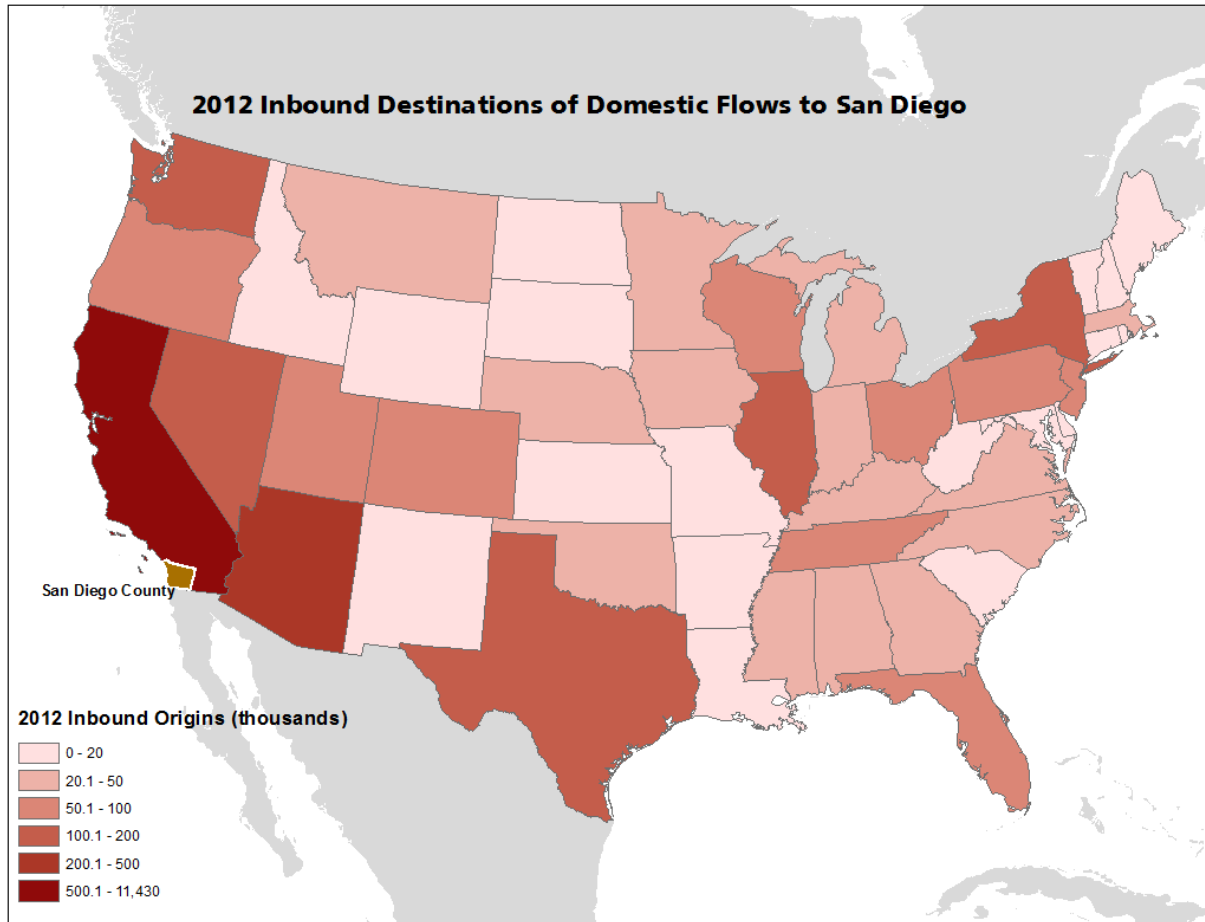

Source: FAF 4

It should be noted that these inbound origins of domestic flows to San Diego reflect freight shipments based upon the FAF survey instrument. This instrument utilizes way bill information that does not include all supply chain links of a beneficial cargo owner (manufacturer/shipper) where a shipment may transfer between freight equipment and/or freight modes. As a result, the higher proportion of inbound origins from California to San Diego may not be representative of the true origin from the shipment

Figure 3.13: Outbound Destinations of Domestic Flows by Truck from San Diego

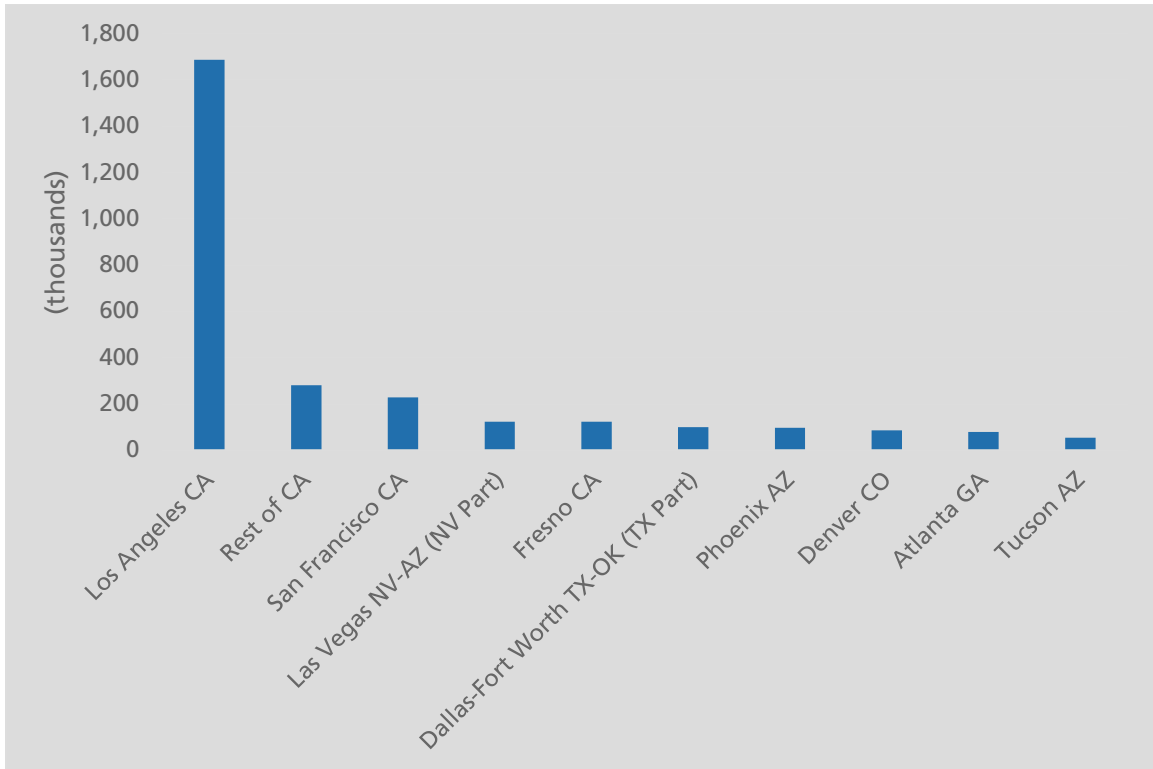

Source: FAF 4

Table 3.8: Top Outbound Destinations of Domestic Flows by Truck from San Diego

Domestic Outbound	2012 Tons (thousands)
Los Angeles, CA	1,688
Rest of CA	281
San Francisco, CA	229
Las Vegas, NV	124
Fresno, CA	124
Dallas-Fort Worth, TX	100
Phoenix, AZ	97
Denver, CO	86
Atlanta, GA	79
Tucson, AZ	55

Source: FAF 4

For Figure 3.13 and Table 3.8 again, Los Angeles is the largest destination point by tonnage flowing out from San Diego. The rest of the state, plus San Francisco and Fresno also are ranked near the top. To the east, there is much less tonnage exiting the region, that tonnage that exits the region is heading to Las Vegas, Dallas – Fort Worth, Phoenix, and Denver, with lesser amounts heading to Atlanta and Tucson.

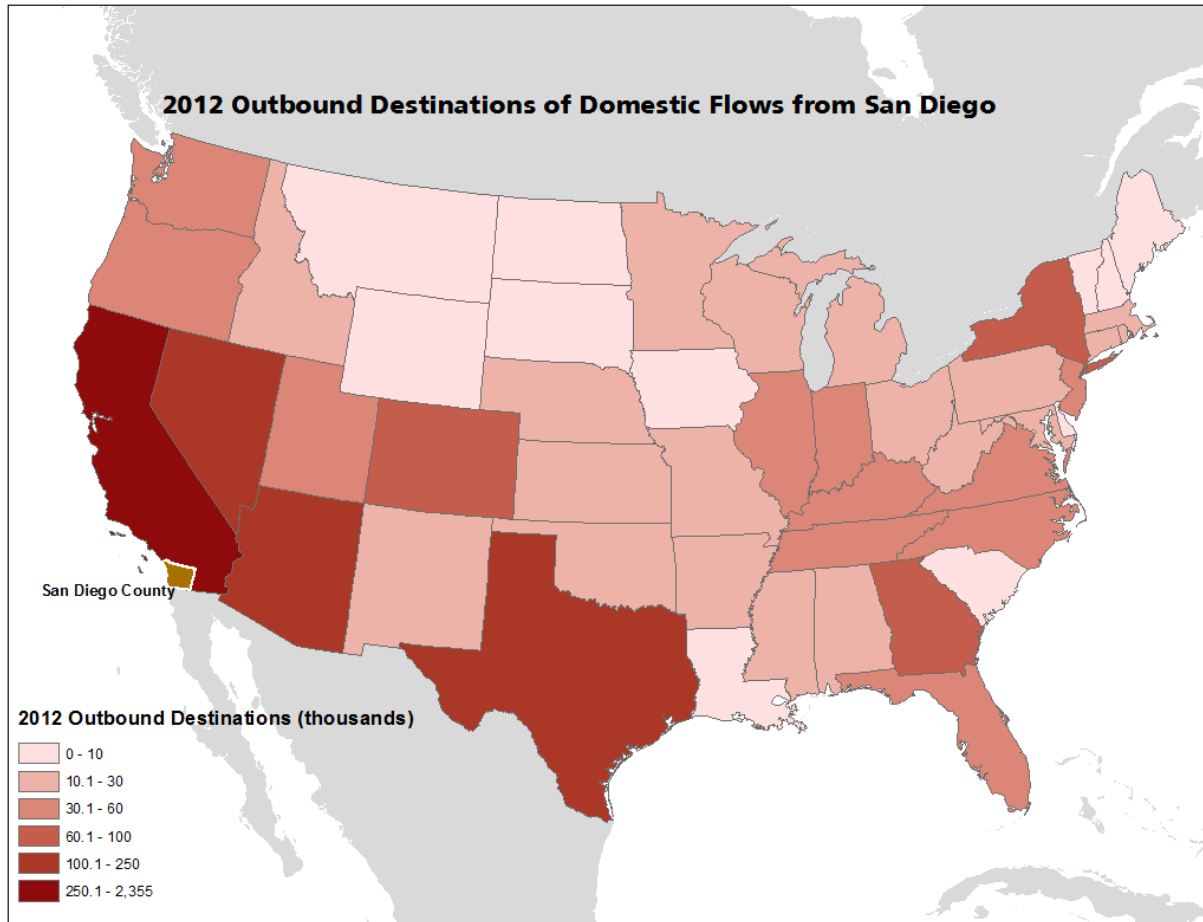

Source: FAF 4

It should be noted that these outbound destinations of domestic flows outside of San Diego reflect freight shipments based upon the FAF survey instrument. This instrument utilizes way bill information that does not include all supply chain links of a beneficial cargo owner (manufacturer/shipper) where a shipment may transfer between freight equipment and/or freight modes. As a result, the higher proportion of outbound destinations to California from San Diego may not be representative of the true destination of the customer.

3.4 International Freight: Corridor Discussion by Tonnage

Table 3.9: Total International Trade Flows to, from, and through San Diego⁷

Direction of Trade	2012 San Diego Tons (thousands)	2012 Through Tons (thousands)
Imports	1,068	4,338
Exports	312	3,193

Source: FAF 4

The total international trade of San Diego is fairly balanced in terms of tonnage, as a higher proportion of imports terminate in San Diego than exports originate there; through tonnage displays a similar snapshot although not as extreme. In both directions of trade the through traffic dominates, demonstrating just how much of a gateway role San Diego plays in international trade for the rest of the United States. As highlighted in the domestic truck section above, the truck mode dominates the majority of imported and exported goods internationally; 72 percent of import tonnage is by truck with the foreign origin in Mexico and 96 percent of export tonnage is by truck with the foreign origin in Mexico. This

Table 3.10: U.S./Mexico Trade Flows by Truck to, from, and through San Diego

Direction of Trade	2012 San Diego Tons (thousands)	2012 Through Tons (thousands)
Imports	290	3,607
Exports	291	3,057

Source: FAF 4

Table 3.10 shows that the Mexico trade by truck at San Diego is similarly, fairly balanced versus overall international trade of San Diego. This balance contrastingly extends to San Diego imports than exports, the reverse of San Diego's overall international trade profile. Mexico through traffic similarly dominates the local San Diego traffic.

⁷ Detailed tables for each freight Gateway, can be found in Appendix B

Figure 3.14: Top 10 Import Commodities by Tonnage and by Truck Moving through San Diego

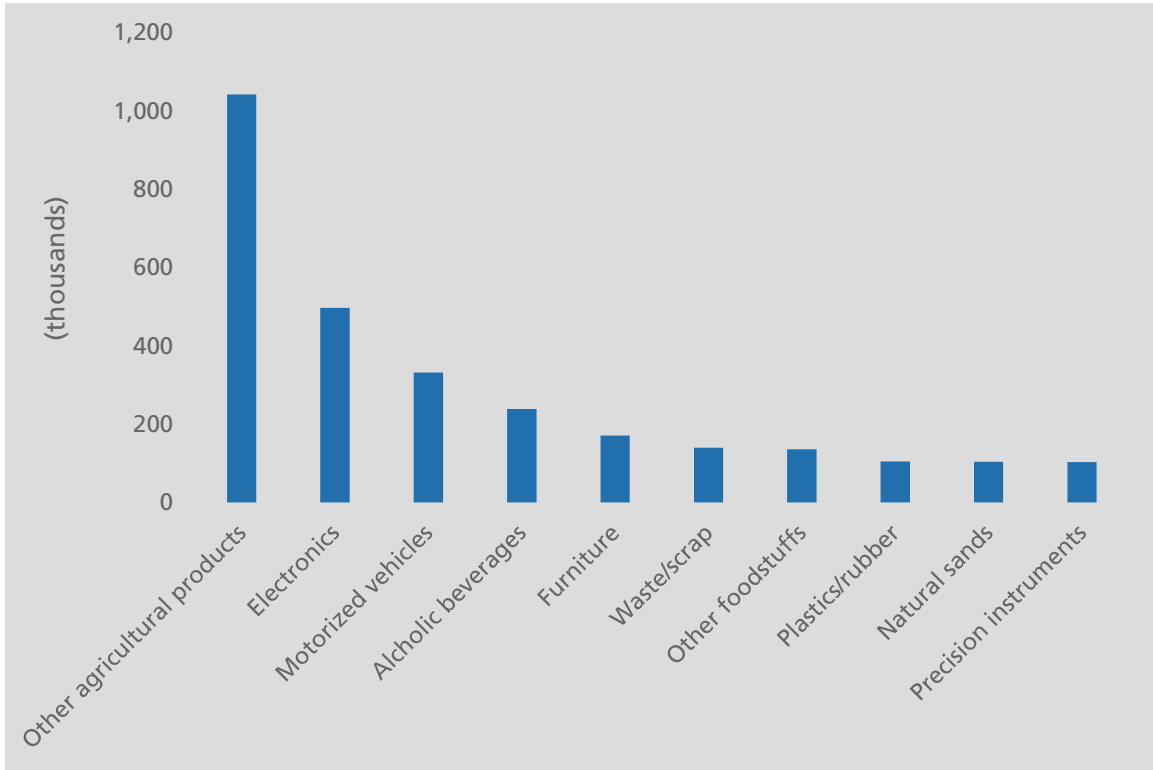

Source: FAF 4

Figure 3.14 shows that the top commodity categories by tonnage imported through San Diego are: other agricultural products, electronics, motorized vehicles, alcoholic beverages, and furniture. Beer makes up a substantial tonnage of the alcoholic beverages category.

Figure 3.15: Top 10 Import Commodities by Tonnage and by Truck Destined for San Diego

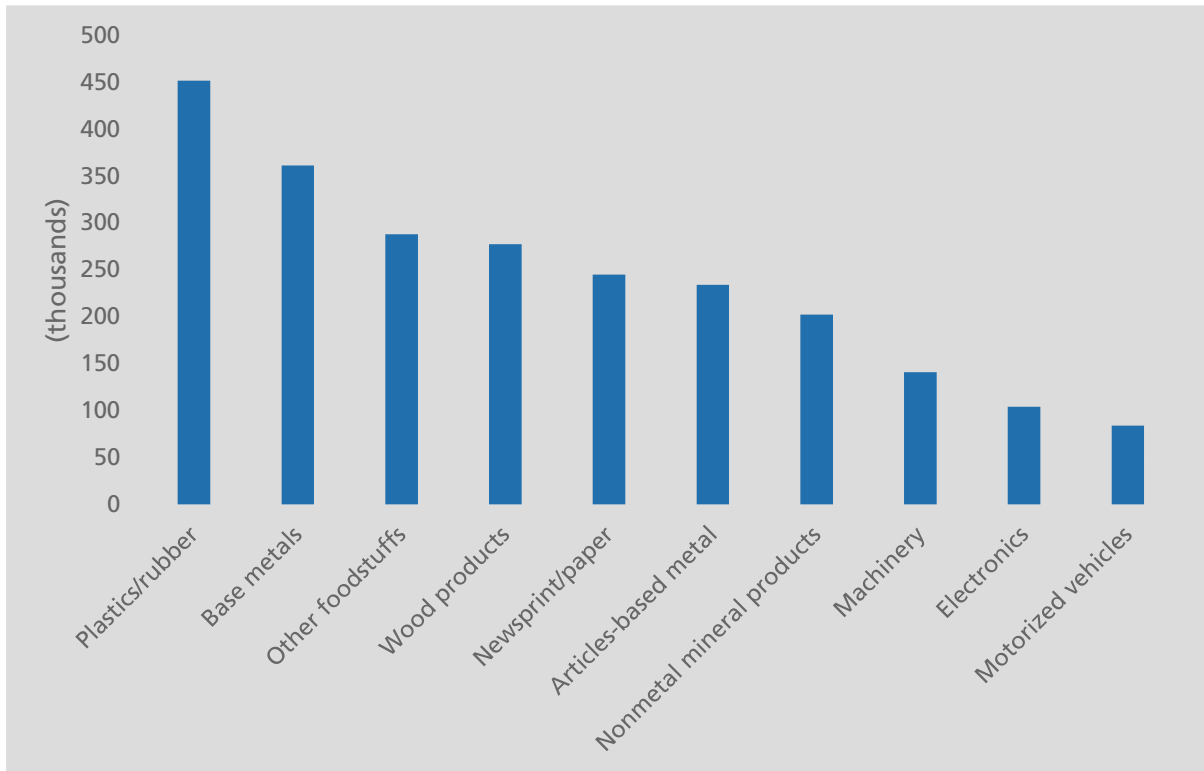

Source: FAF 4

The top 10 commodity categories imported to San Diego shown in Figure 3.15 are other agricultural products, electronics, motorized vehicles and waste/scrap, followed by other foodstuffs. The other agriculture products dominate the local imports from Mexico, reflecting the strong local market handling of these Mexican agricultural goods.

Figure 3.16: Top 10 Export Commodities by Tonnage and by Truck Moving through San Diego

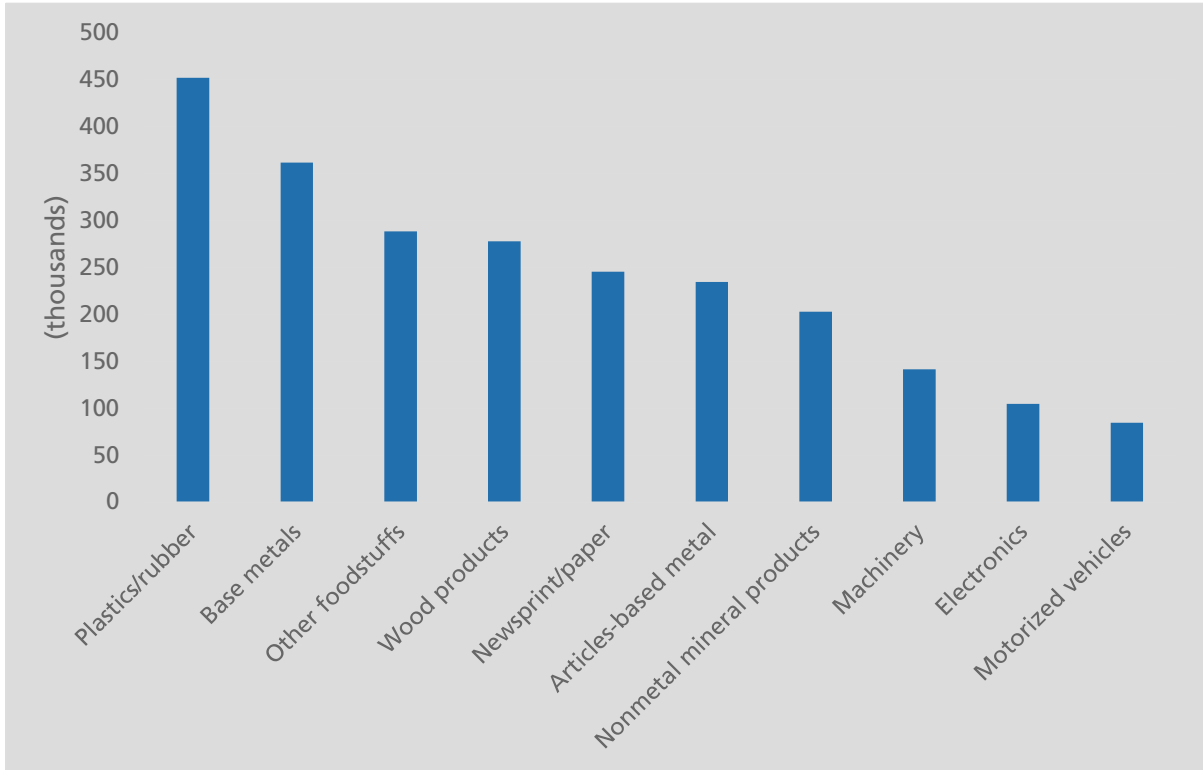

Source: FAF 4

Figure 3.16 shows the top 10 commodity categories exported through San Diego, including plastics/rubber, base metals, other foodstuffs, wood products, newsprint/paper, and articles-based metal. This diversified mix of commodity categories reflects the integration of the Baja California economy with goods sourced from the United States and exported to Mexico through San Diego.

Figure 3.17: Top 10 Export Commodities by Tonnage and by Truck Shipped from San Diego

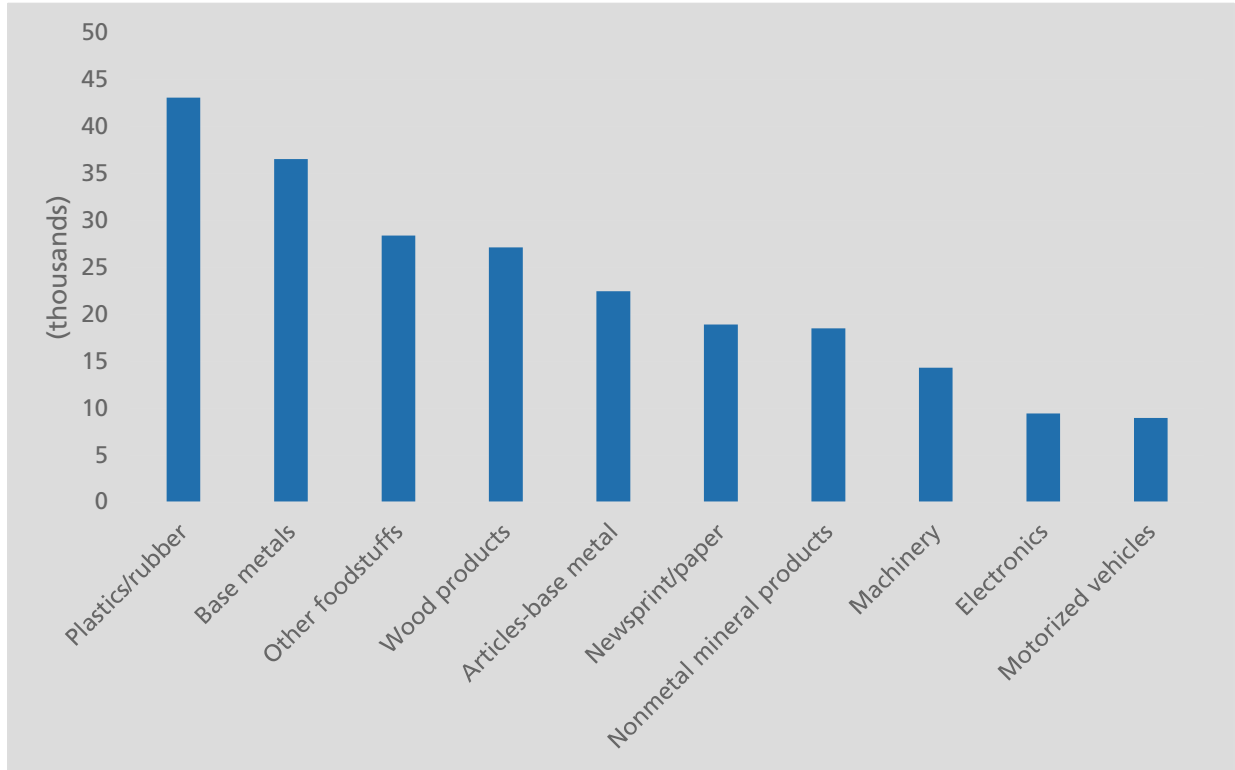

Source: FAF 4

Figure 3.17 shows the top 10 commodity categories exported from San Diego and reflects the mix of exports from the United States that Baja California imports, namely plastics/rubber, base metals, other foodstuffs, wood products, articles-based metal, newsprint/paper, nonmetal mineral products, machinery, electronics, and motorized vehicles.

The fact that San Diego is the origin of this diversified mix of commodity categories reflects the important role of regional freight networks which facilitate both north and southbound trade moving to Baja California. Goods of many types sourced from across the United States are exported to Mexico through San Diego. Some of these exports to Mexico are then used as inputs to Mexican manufacturing, which become finished products then exported by Mexico (some of these finished products are then destined for export back to the United States).

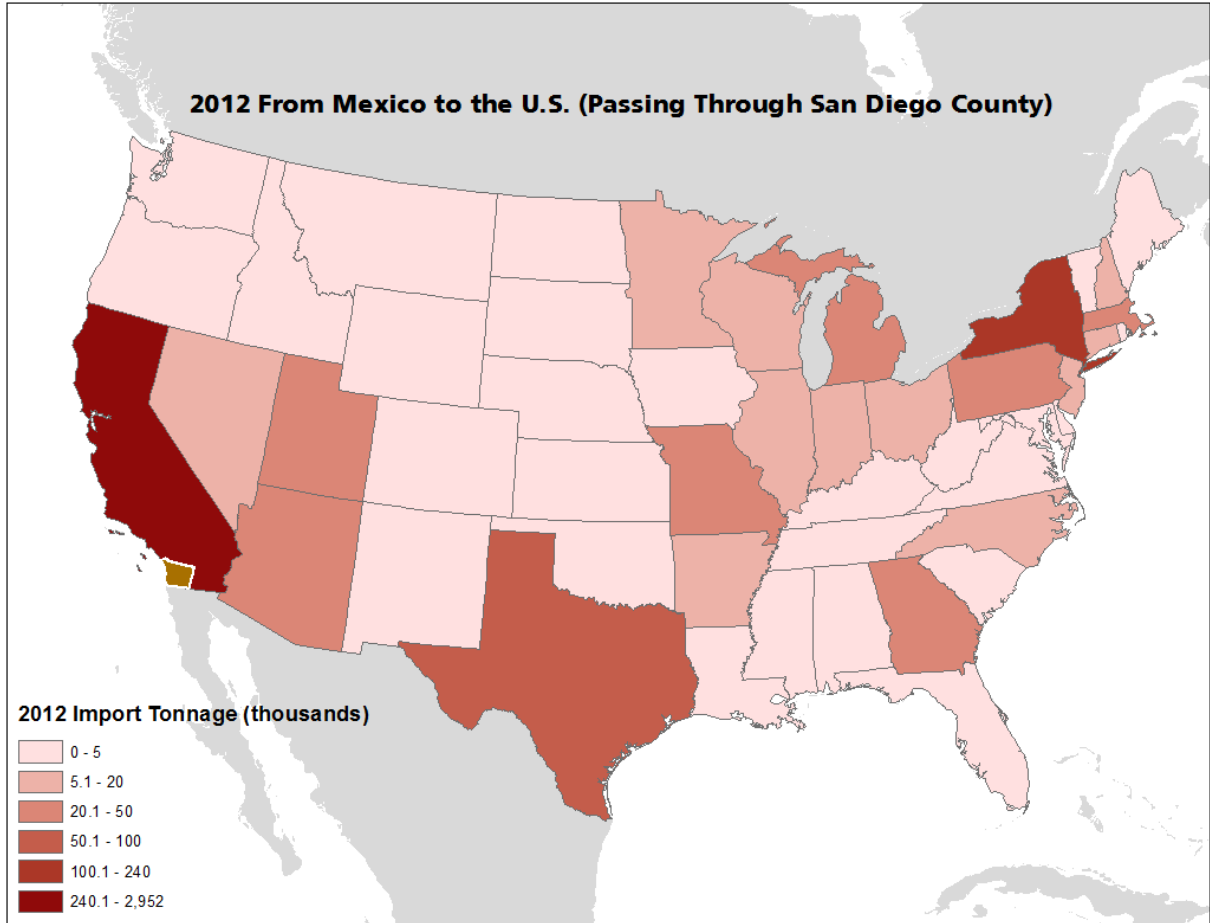

Source: FAF 4

When considering imported tonnage from Mexico to the rest of the United States passing through San Diego County by truck, 82 percent of the volume is initially destined to California and the remaining 18 percent initially destined to the rest of the United States. Other states in the United States with significant imported tonnage through San Diego County include New York (7%).

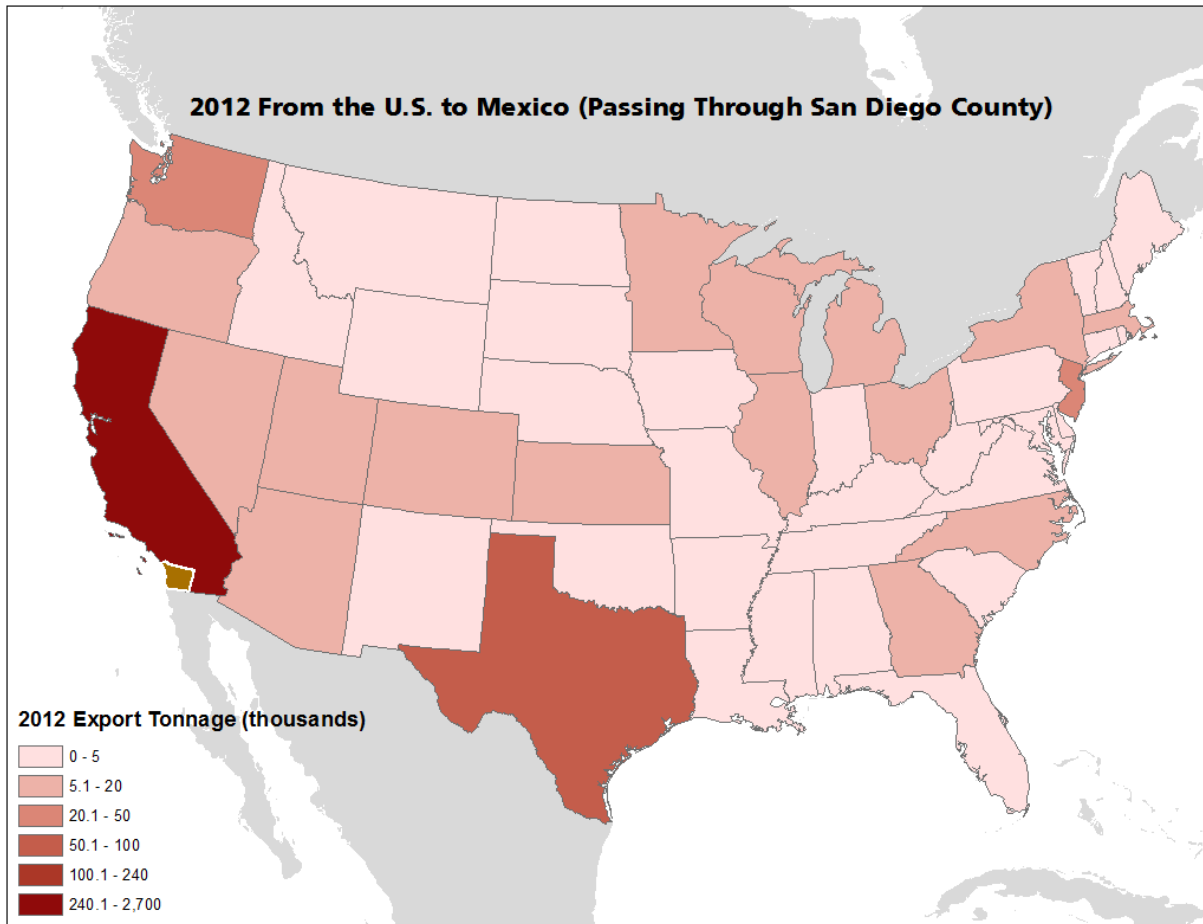

Source: FAF 4

When considering exported tonnage from the United States to Mexico passing through San Diego County by truck, 88 percent of the volume came from California and 12 percent from the rest of the United States. Other states in the United States with significant exported tonnage through San Diego County include Texas (2%).

It should be noted that these import/export international flows through San Diego reflect freight shipments based upon the FAF survey instrument. This instrument utilizes way bill information that does not include all supply chain links of a beneficial cargo owner (manufacturer/shipper) where a shipment may transfer between freight equipment and/or freight modes. As a result, the higher proportion of import/export, origins/destinations between California and Mexico may not be representative of the true import/export patterns.

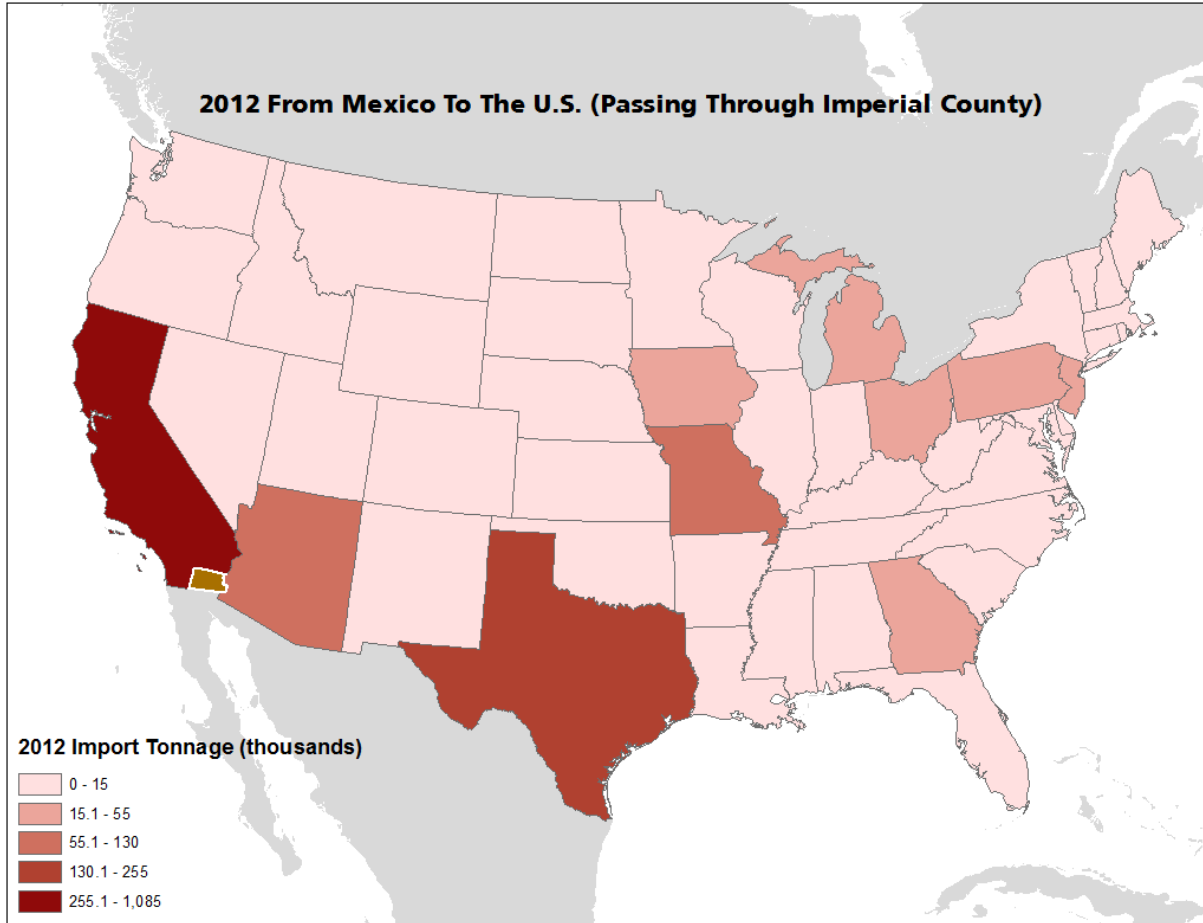

Source: FAF 4

When considering imported tonnage from Mexico to the rest of the United States passing through Imperial County by truck, 59 percent of the volume is initially destined to California and the remaining 41 percent initially destined to the rest of the United States. Other states in the United States with significant imported tonnage through Imperial County include Texas (14%), Missouri (7%) and Arizona (6%).

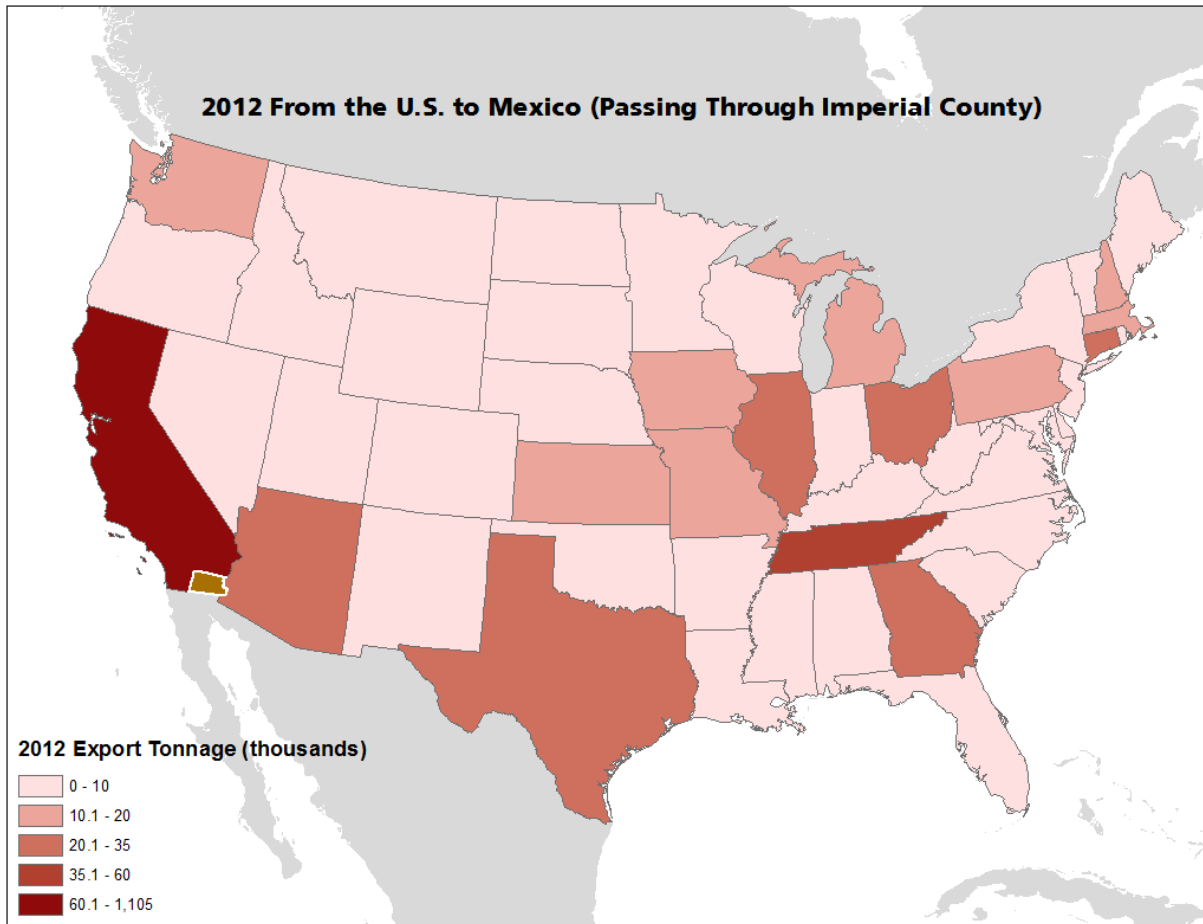

Source: FAF 4

When considering exported tonnage from the United States to Mexico passing through Imperial County by truck, 73 percent of the volume came from California and 27 percent from the rest of the United States. Other states in the United States with higher exported tonnage through Imperial County to Mexico include Tennessee (4%), Illinois (2%), Arizona (2%), Georgia (2%) and Texas (2%).

It should be noted that these import/export international flows through Imperial County reflect freight shipments based upon the FAF survey instrument. This instrument utilizes way bill information that does not include all supply chain links of a beneficial cargo owner (manufacturer/shipper) where a shipment may transfer between freight equipment and/or freight modes. As a result, the higher proportion of import/export origins/destinations between California and Mexico may not be representative of the true import/export patterns.

Figure 3.18: Value of U.S. Content in Imports

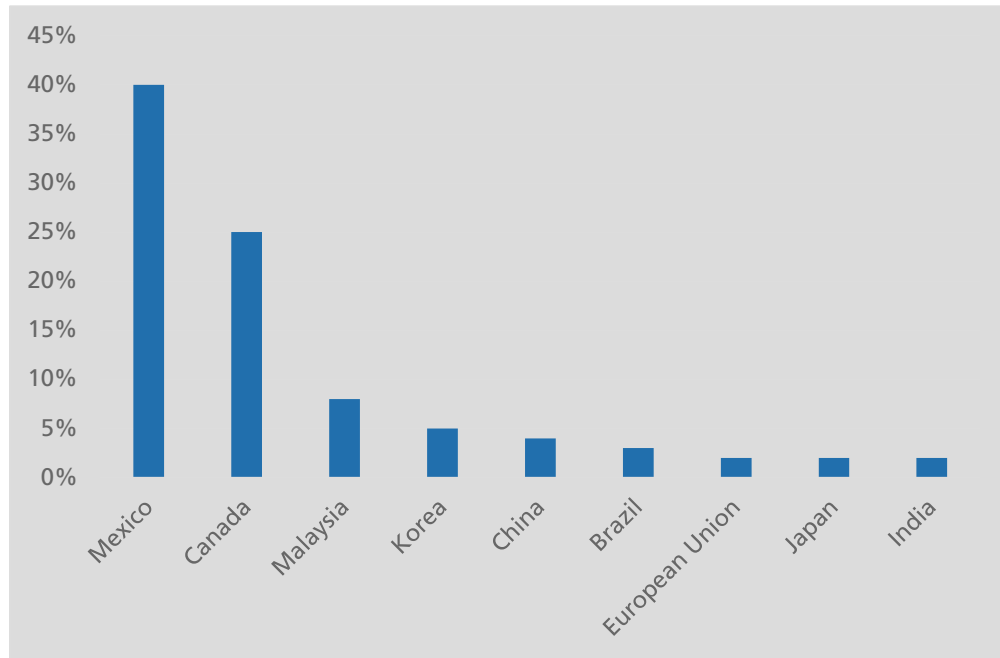

Source: National Bureau of Economic Research: NBER Working Paper Series Give Credit Where Credit is Due: Tracing Value Added in Global Production Chains

As mentioned above, Figure 3.18 provides an illustration of the relative percentage of U.S. content provided within imports from top U.S. trading partners. Mexico, at 40 percent clearly provides the highest value of U.S. content contained within imports when compared to the top U.S. trading partners. Canada is second at 25 percent with all other trading partners being below 10 percent.

3.5 Truck International and Domestic Freight: 2050 Gateway Forecast

As highlighted in Chapter 1, Figure 3.19 below provides a comparison of the 2012 base year versus the 2050 forecast for the region’s international gateways. From this, it is clear that the truck mode dominates the amount of tonnage moving through the region’s gateways, as forecasts are for tonnage to grow between 35 to 55 million for San Diego and Imperial Counties.

Figure 3.19 Summary of Freight Flows through the Regions International Gateways by Modal Volume: 2050 Forecast

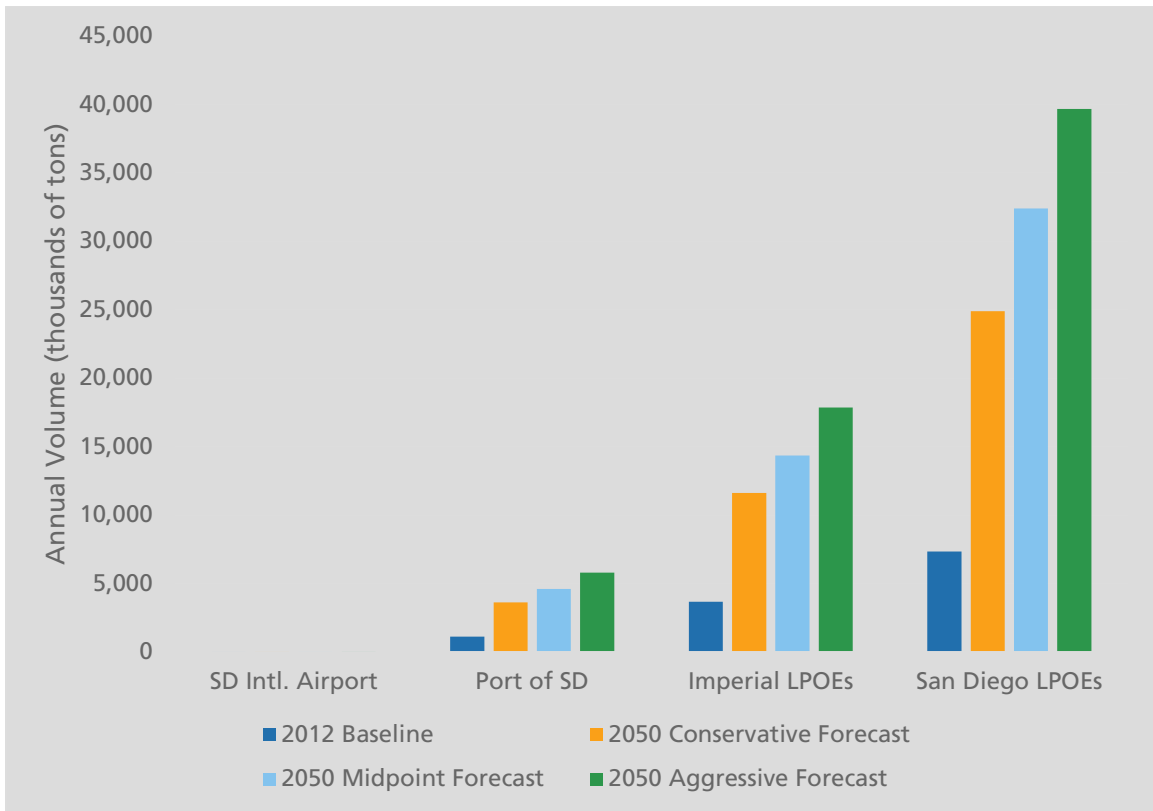

Source: FAF 4, U.S. Army Corps of Engineers, and San Diego International Airport

Chapter 1 also provides the information below from Figure 3.20 which depicts the amount of tonnage moving through the San Diego region either internally or domestically (inbound and outbound). During the 2012 base year, 50 million tons were generated with nearly 65 percent of those tons being internal. By 2050, the internal and domestic tonnage is forecasted to reach between 68 and 83 million tons with nearly 55 percent of those tons being internal.

Figure 3.20 Domestic Truck Circulation: 2050 Forecast

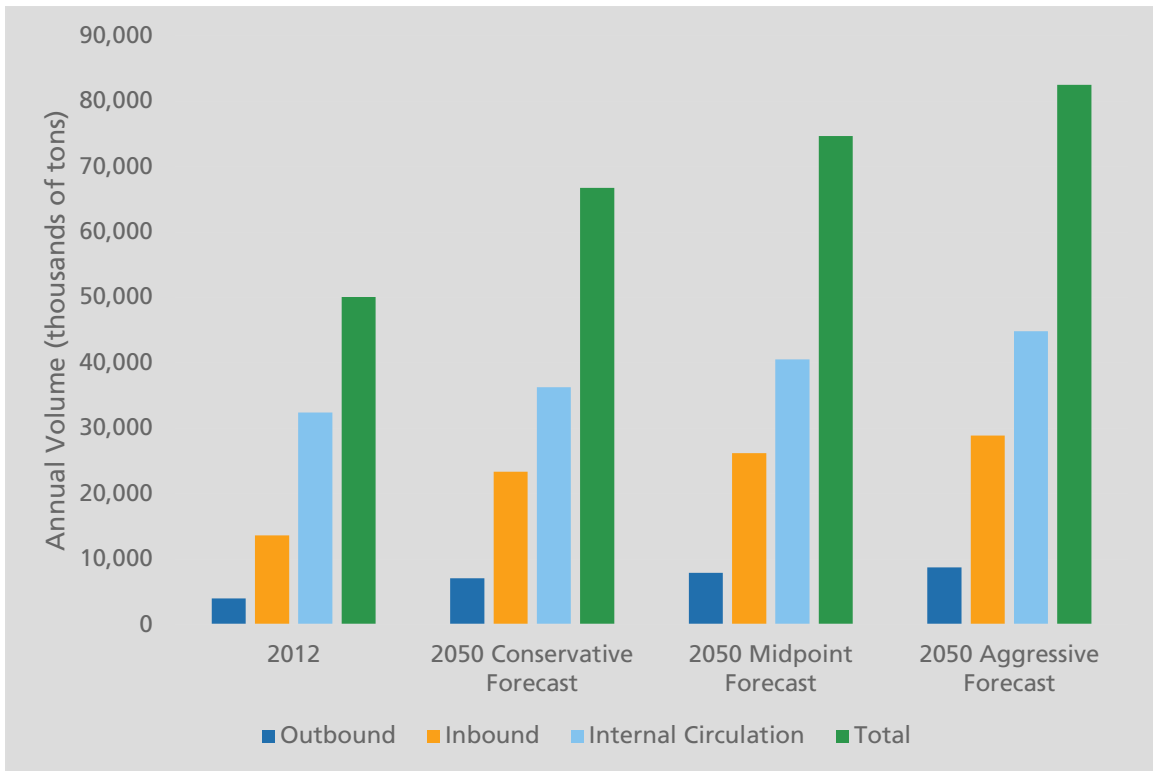

Source: FAF 4

When considering the commodities traversing the San Diego region from an internal and domestic tonnage perspective, and also factoring in international gateway flows, the case becomes clear regarding the importance of the I-5 and I-15 freeway corridors as the primary trucking arteries carrying the substantial majority of this tonnage. Whether looking at domestic or international goods movement flows, the majority of origin and destination pairs are between the Los Angeles metropolitan area and San Diego. This is most notably illustrated by the development of significant industrial clusters in Los Angeles and the Inland Empire which provide warehousing and distribution nodes that supply consumer-based product demand to San Diego County; as well as intermediary and value-added production of finished goods throughout southern California and the rest of the United States.

Figure 3.21 2012 San Diego Region Truck Tonnage Breakdown

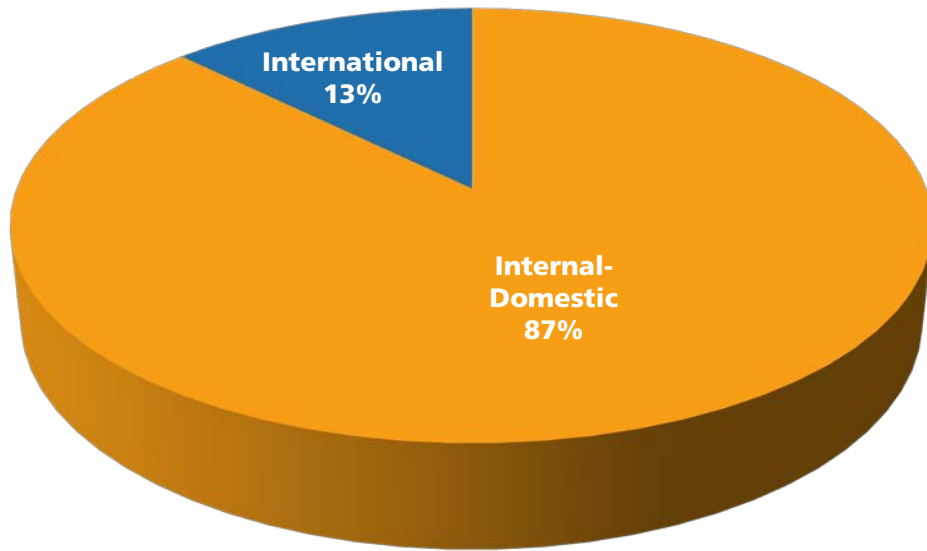

Source: FAF 4

Internal and domestic tonnage compared with international tonnage for 2012 as depicted in Figure 3.21 illustrates the fact that the region's consumption patterns generate a substantial majority of tonnage flows.

Figure 3.22 2050 Conservative Forecast San Diego Region Truck Tonnage Breakdown

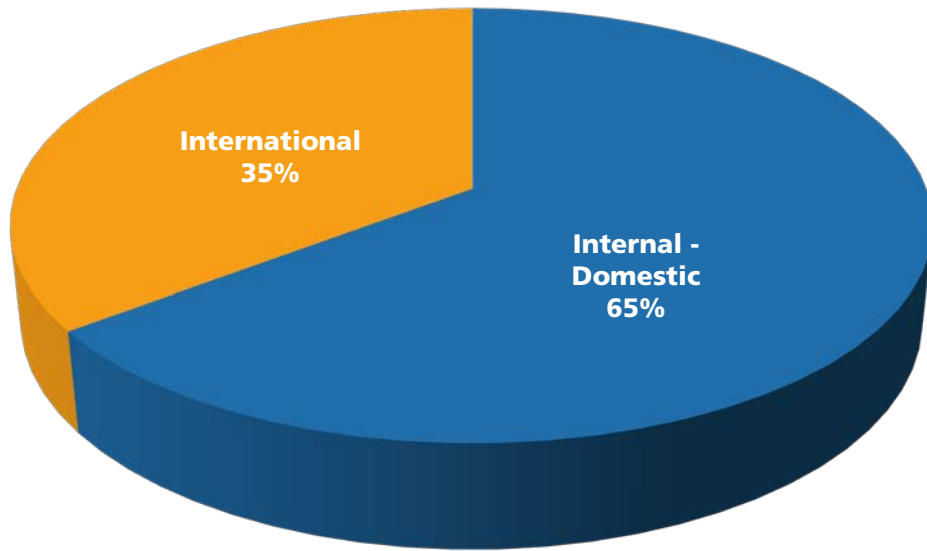

Source: FAF 4

Figure 3.23 2050 Midpoint Forecast San Diego Region Truck Tonnage Breakdown

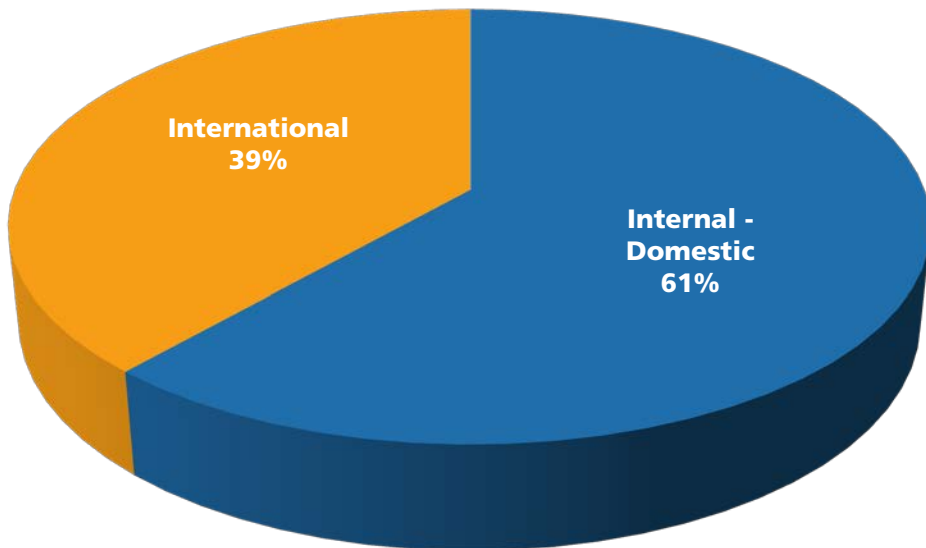

Source: FAF 4

Figure 3.24 2050 Aggressive Forecast San Diego Region Truck Tonnage Breakdown

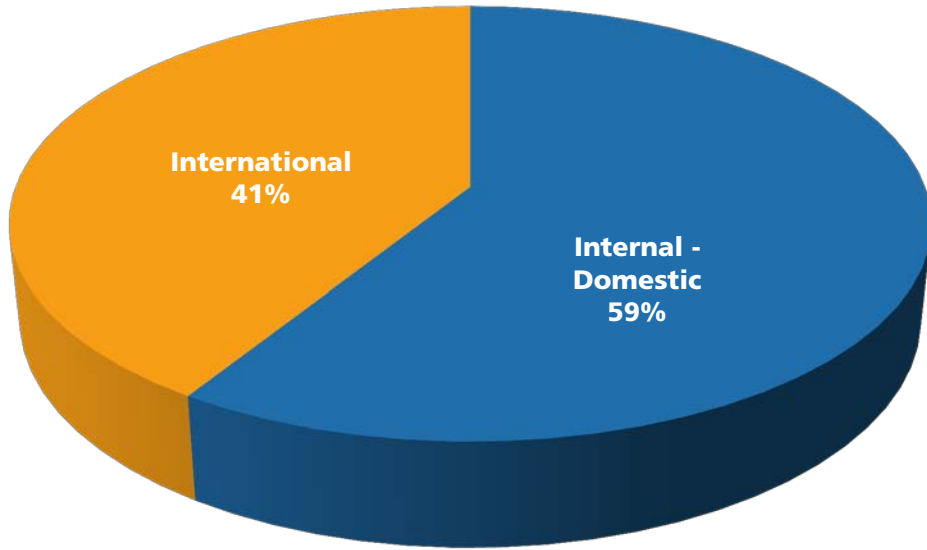

Source: FAF 4

Looking out to the forecast horizon year in 2050, the growth of international tonnage is expected to significantly outpace the portion of tonnage moved through the region internally and domestically. This dynamic greatly solidifies the statements made throughout this report that the importance of the I-5 and I-15 freeway corridors will be paramount as the region's truck tonnage continues to grow. As depicted in the Gateway Forecast Tables (Appendix B), international gateway truck mode growth is forecasted to grow over two times faster than internal and domestic truck annual tonnage growth.

Figure 3.25 Supply Chain Relationships Between: International Ports of Entry, the Ports of Los Angeles/Long Beach, and the Inland Empire



Source: IBI Group

As shown in Figure 3.24, international, domestic and internal truck flows are all interrelated. The Ports of Los Angeles and Long Beach, the warehousing and distribution of Los Angeles and the Inland Empire and the land ports of Otay Mesa and Calexico East form the key network nodes which generate truck flows throughout southern California. Based on these circumstances, the San Diego region should continue to prioritize the I-5 and I-15 freeway corridors when considering freight project needs.

Table 3.11: Otay Mesa POE Top Five Commodities by Trade Value

Otay Mesa POE Commodities	2015 Trade Value (millions)
Electrical machinery, equipment and parts	\$16,099
Vehicles and parts	\$5,015
Medical and other instruments	\$3,756
Machinery, mechanical appliances and parts	\$2,821
Plastics and articles	\$2,402

Source: Bureau of Transportation Statistics

The top five commodities by trade value imported and exported through the Otay Mesa POE are listed in Table 3.11 above. Notable products from these commodity categories included flat screen TVs and pick-up trucks, as well as medical devices for DJ Orthopedics. Many of the plastics and articles as well as parts from the other commodity categories are used as inputs to the manufacturing process.

Table 3.12: Otay Mesa POE Top Five Imported Commodities by Tons

Otay Mesa POE Commodities	2015 Short Tons
Edible vegetables	725,243
Vehicles and parts	685,476
Electrical machinery, equipment and parts	585,257
Edible fruit and nuts	417,569
Beverages including spirits and vinegar	337,164

Source: Bureau of Transportation Statistics

Short ton information is provided by the Bureau of Transportation Statistics (BTS) for imports only into the United States. The import information is telling in that the top trade value commodities are not all equally related to the top tonnage commodities crossing the border. Vegetables, fruit and nuts as well as beverages included some of the highest tonnage goods entering the United States through the Otay Mesa POE during 2015.

Table 3.13: Calexico East POE Top Five Commodities by Trade Value

Calexico East POE Commodities	2015 Trade Value (millions)
Electrical machinery, equipment and parts	\$5,895
Machinery, mechanical appliances and parts	\$2,194
Vehicles and parts	\$1,544
Medical and other instruments	\$900
Aircraft, spacecraft and parts	\$638

Source: Bureau of Transportation Statistics

The top five commodities by trade value imported and exported through the Calexico East POE are listed in Table 3.11 above. The majority of these commodities are similar to Otay Mesa, however with some proportional differences. Similarly, parts from the other commodity categories are used as inputs to the manufacturing process.

Table 3.14: Calexico East POE Top Five Imported Commodities by Tons

Calexico East POE Commodities	2015 Short Tons
Edible vegetables	316,613
Glass and glassware	216,284
Electrical machinery, equipment and parts	168,443
Beverages including spirits and vinegar	157,515
Vehicles and parts	138,019

Source: Bureau of Transportation Statistics

Similar to Otay Mesa, short ton information is provided by the BTS for imports only into the United States through Calexico East. The import information is very similar with the top trade value commodities are not all equally related to the top tonnage commodities crossing the border. Vegetables, glass and glassware as well as beverages included some of the highest tonnage goods entering the United States through the Calexico East POE during 2015.

3.6 International Freight: Key Commodities at the Port of San Diego by Tonnage

Table 3.15: Port of San Diego Top Imported Commodities

Port of San Diego Top Imported Commodities	2012 Short Tons	Percent of Total
Bananas & Plantains	433,628	37.5%
Vehicles & Parts	377,262	32.6%
Nitrogenous Fertilizers	100,233	8.7%
Fertilizers & Mixers	57,615	5.0%
Fruit & Nuts	51,220	4.4%
Aluminum Ore	28,660	2.5%
Other	24,476	2.1%
Metallic Salts	20,673	1.8%
Total Short Tons	1,155,552	100.0%

Source: U.S. Army Corps of Engineers

Roughly 70 percent of the imported short tons into the Port of San Diego include bananas, plantains, vehicles, and vehicle parts. For agricultural products, bananas, plantains, and fruit and nuts reflected roughly 42 percent of total short tons imported. For fertilizers, nitrogenous fertilizers, and other fertilizers and mixers reflected roughly 14 percent of the short tons imported during 2012. Aluminum ores, other unidentified commodities, and metallic salts also reflected higher short tons.

Table 3.16: Port of San Diego Top Exported Commodities

Port of San Diego Top Exported Commodities	2012 Short Tons	Percent of Total
Metallic Salts	16,455	57.6%
Alcoholic Beverages	3,170	11.1%
Rubber & Plastic Products	1,685	5.9%
Electrical Machinery	1,343	4.7%
Total Short Tons	28,587	100.0%

Source: U.S. Army Corps of Engineers

The majority of exported short tons included metallic salts during 2012. Other notable exported commodities included alcoholic beverages, rubber and plastic products, and electrical machinery. When compared to imported short ton totals, exported short tons reflected a 2 percent proportional volume during 2012.

3.7 Air Cargo Freight: Domestic, International, and Mail Cargo at the San Diego International Airport

Table 3.17: San Diego International Airport Domestic Cargo

San Diego International Airport Domestic Cargo	2012 Tons	Percent of Total
Enplaned⁸	67,132	50.9%
Deplaned⁹	64,693	49.1%
Total Tons	131,825	100.0%

Source: San Diego International Airport

During 2012, 51 percent of domestic air cargo tonnage was enplaned and shipped out of the county, while 49 percent was deplaned within the county as the shipping destination. Compared to international and mail air cargo, domestic total tonnage represents 85 percent¹⁰ of all air cargo tonnage (air cargo does not include U.S. mail traffic).

Table 3.18: San Diego International Airport International Cargo

San Diego International Airport International Cargo	2012 Tons	Percent of Total
Enplaned	4,213	71.6%
Deplaned	1,674	28.4%
Total Tons	5,887	100.0%

Source: San Diego International Airport

During 2012, 72 percent of international air cargo tonnage was enplaned and shipped out of the county, while 28 percent was deplaned within the county as the shipping destination. Compared to domestic and mail air cargo, international total tonnage represents less than 4 percent¹¹ of all air cargo tonnage.

⁸ Modified definition from the Port of Seattle Airport Statistics Glossary, "Enplaned cargo is defined as the total number of tons of air freight by airline, being loaded."

⁹ Modified definition from the Port of Seattle Airport Statistics Glossary, "Deplaned cargo is defined as the total number of tons of air freight by airline, being unloaded."

¹⁰ The 85% is calculated by combining the 2012 total air cargo tonnage (141,924) and total mail cargo tonnage (18,003) equaling 159,927 tons. Total domestic air cargo tonnage (131,825) is divided by 159,927 tons.

¹¹ The 4% is calculated by combining the 2012 total air cargo tonnage (141,924) and total mail cargo tonnage (18,003) equaling 159,927 tons. Total international air cargo tonnage (5,887) is divided by 159,927 tons.

Table 3.19: San Diego International Airport Mail Cargo

San Diego International Airport Mail Cargo	2012 Tons	Percent of Total
Enplaned	13,802	76.7%
Deplaned	4,202	23.3%
Total Tons	18,003	100.0%

Source: San Diego International Airport

During 2012, 77 percent of mail air cargo tonnage was enplaned and shipped out of the county, while 23 percent was deplaned within the county as the shipping destination. Compared to domestic and international air cargo, mail total tonnage represents less than 12 percent¹² of all air cargo tonnage.

Combined, the 155,715 tons for domestic, international, and mail air cargo have a corresponding relationship with the trucks bringing the packages which are enplaned and deplaned at the airport. As air cargo tonnage increases over time, truck volumes picking up and dropping off shipments will continue to grow.

3.8 Gateway Supply Chain Example Vignettes

Because freight flow activity within the Gateway region varies significantly by the type of commodity and the complexity of the supply chains it supports, it is helpful to focus on some key example commodities commonly shipped within the region. To illustrate, three vignettes follow which demonstrate the uniqueness of each category of goods in terms of how goods move as a network business and how goods utilize various modes of transportation, hence the term “supply chain” is now used to describe the multi-modal and intermodal movement of goods. The purpose of the commodity specific vignettes is to take the static commodity and tonnage tables previously cited, and tell a much more dynamic story about how real commodities flow across the region’s infrastructure. These vignettes represent supply chain activity with an emphasis on a specific year. Some information, while more current than the base year forecast, provides a one-year snapshot of the freight environment in San Diego County.

In Appendices 3 through 5, there are three detailed vignettes covering three import freight commodities moving in our region. The San Diego region hosts the specialized niche Port of San Diego, unique air cargo operations at San Diego International Airport, and specialized border cargo (reflecting key regional economic clusters) moving across the main commercial land POEs, Otay Mesa and Calexico East. The vignettes illustrate why certain cargoes function well in our region as well as how regional planning agencies should understand these supply chain network interactions.

¹² The 12% is calculated by combining the 2012 total air cargo tonnage (141,924) and total mail cargo tonnage (18,003) equaling 159,927 tons. Total mail cargo tonnage (18,003) is divided by 159,927 tons.

- Vehicles-Imported vehicles, vehicle parts, and exported vehicle parts pass through our region by truck, by ship, and by rail. The imported vehicle business is a key component of economic activity occurring at the Port of San Diego and across the Otay Mesa and Calexico East POEs; in fact there are interactions involving vehicle imports by truck across the border which leave the region by both rail and truck (Appendix C).
- Electronics-Advanced electronics, especially TV components, are a critical economic function for our border region. Significant tonnages of electronic components, which are inputs to TV production in Mexico, are produced within or enter our region. These electronic components cross the Otay Mesa and Calexico East POEs and then return for national distribution as finished products for nationwide distribution (Appendix D).
- Perishables-Perishables are another important commodity generating several rounds of economic activity and a commodity group that moves through several intricate supply chain connections. The perishable vignette will detail how fresh food commodities (primarily bananas) enter the Port of San Diego; the perishables are turned into mixed loads of fresh fruits (on or off the port) and trucked out on a just-in-time basis for consumption. Similarly, noteworthy tonnages of perishables are imported and exported across the Otay Mesa and Calexico East border crossings as depicted in Figure 3.25 (Appendix E).

Figure 3.26: San Diego Perishables Freight Flows

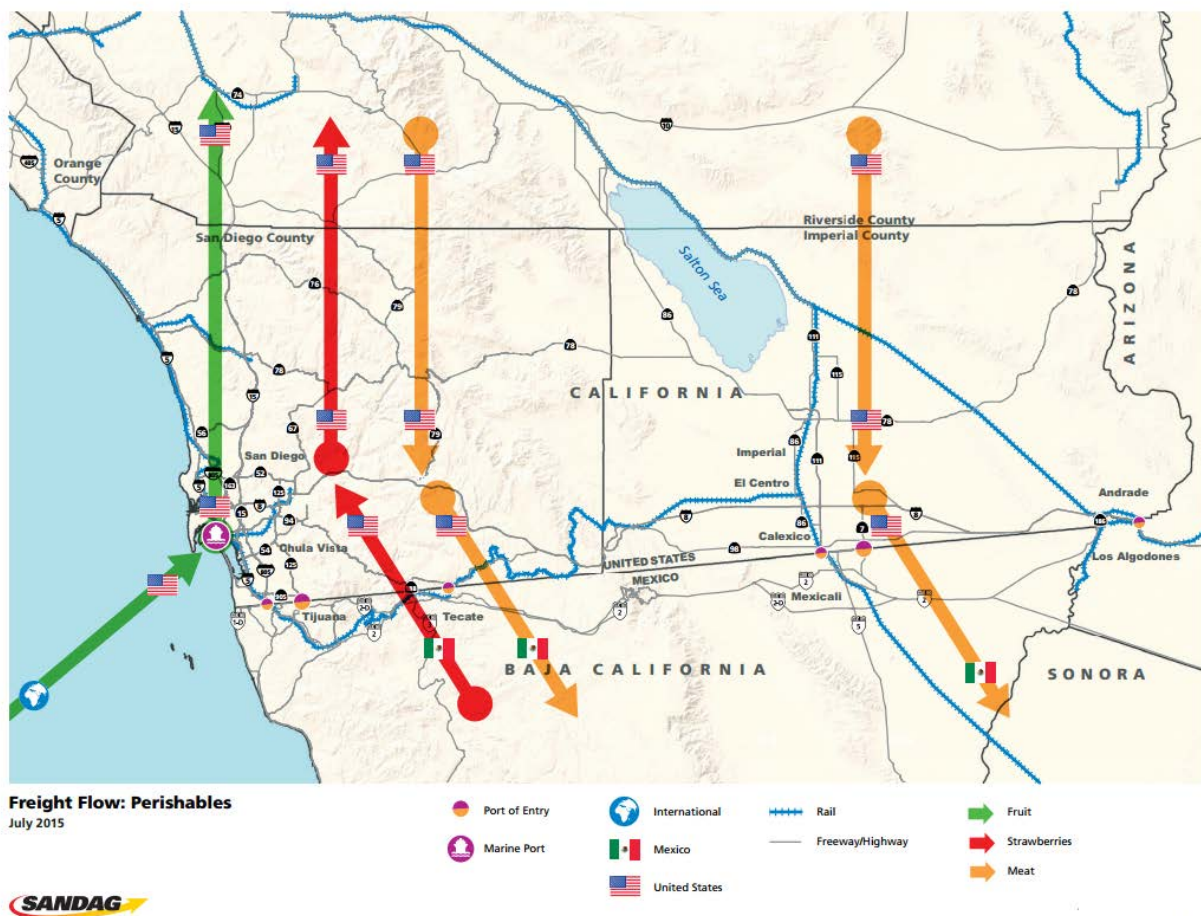

Source: San Diego Freight Rail Consulting

4 POLICY CONSTRAINTS, MARKET CONDITIONS, AND REGULATORY ISSUES

The primary focus of this Freight Gateway Study Update is to provide an updated economic forecast of anticipated long-term freight flows moving into, out of, within, and through the region. In addition to the underlying economic forces driving the forecasts, there are policy, market, and regulatory issues which can significantly affect how freight moves in the region. The results of the interplay of these issues cannot be fully captured in the quantitative forecasts, so freight planning agencies have to regularly monitor developments to consider the forecasts in context.

One can visualize the complexity of policy, market, and regulatory influences on freight planning almost as a freight dashboard. While the issues both change with circumstances, and a change in one area influences change in another area, use of a schematic “freight policy dashboard,” such as this, shows the breadth of the issues across international, national, state, and local levels, plus the private sector that operate the system subject to policy constraints.

Figure 4.1 Freight Schematic “Dashboard” Policy Challenges

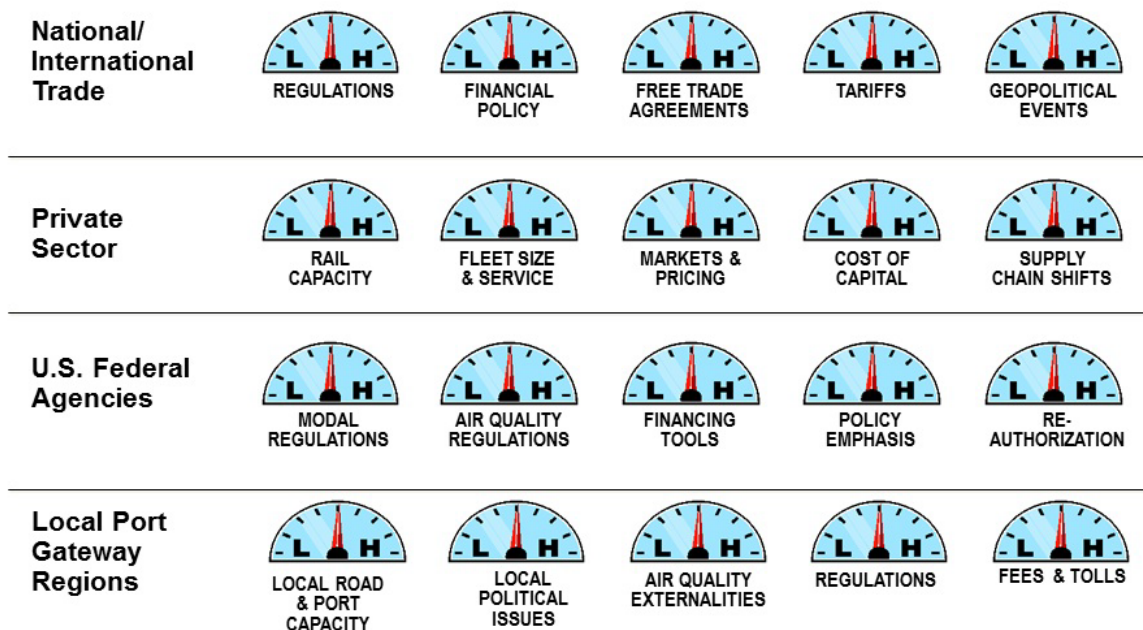

This report section highlights policy, market, and regulatory issues (inclusive of federal, state and local regulatory issues) that should be monitored. Each issue is presented individually, yet how they evolve will reflect their interdependencies. This section is an update to the set of issues presented in the original Comprehensive Border Gateway study in 2010 and reflects what is known at the time this Freight Gateway Study Update is written. This list will continue to change over time, and regular monitoring of freight-related trends must accompany interpretation of this updated Gateway Study.

4.1 Freight Policy Issues

4.1.1 Funding Availability and Funding Priorities

Freight planning in the public sector is receiving increasing attention from policymakers yet is still a developing discipline. The complexities of freight and logistics are driven by private sector entities, leaving public freight planners with additional challenges in both processing the logistical decisions and attempting to adjust public planning responses accordingly. The new attention to freight planning is still in the development of producing a coherent and consistent national, regional, or local freight framework to help organize the freight planning and funding activities of public agencies. Some freight projects clearly only have local dimensions. Other freight projects are regionally, nationally, or even internationally important, yet there is still a nascent institutional structure to consider them consistently or help local agencies having to deal with them in their own planning. Freight planners have to work with varying freight performance measures related to international seaports and airports, international border crossings, and rail operations that have both local and national benefits and impacts. Additionally, as most freight projects involve private interests, funding solutions often demand complex funding partnerships crafted on a case by case basis.

In 2012, Congress took initial steps toward making freight planning more comprehensive and national with a framework of performance-based state-driven freight planning. This included the goal of development of the first national freight transportation strategy, yet incomplete in both funding to implement it and in the details defining the network. In December 2015, Congress passed the Fixing America's Surface Transportation (FAST Act). The FAST Act authorized \$305 billion over fiscal years 2016 through 2020, including nearly \$11 billion in provisions focused on ensuring the safe, efficient, and reliable movement of freight. Specifically, for freight, the Fast Act:

- *Establishes a National Multimodal Freight Policy that includes national goals to guide decision-making.*
- *Requires the Development of a National Freight Strategic Plan to implement the goals of the new National Multimodal Freight Policy.* The National Strategic Freight Plan will address the conditions and performance of the multimodal freight system, identify strategies and best practices to improve intermodal connectivity and performance of the national freight system, and mitigate the impacts of freight movement on communities.
- *Creates a new discretionary freight-focused grant program that will invest \$4.5 billion over five years.* This new program allows States, Metropolitan Planning Organizations (MPOs), local governments, tribal governments, special purpose districts and public authorities (including port authorities), and other parties to apply for funding to complete projects that improve safety and hold the greatest promise to eliminate freight bottlenecks and improve critical freight movements.
- *Establishes a National Highway Freight Program.* The Act provides \$6.3 billion in formula funds over five years for States to invest in freight projects on the National Highway Freight Network. Up to 10 percent of these funds may be used for intermodal projects.

- *Includes new authorities and requirements to improve project delivery and facilitate innovative finance.* The FAST Act includes provisions intended to reduce the time it takes to break ground on new freight transportation projects, including by promoting best contracting practices and innovating financing and funding opportunities and by reducing uncertainty and delays with respect to environmental reviews and permitting.
- *Collects performance measures for leading U.S. maritime ports.* The FAST Act requires the Bureau and Transportation Statistics (BTS) to collect and annually report performance measures for the nation's top 25 ports, as measured by three methods (total tonnage, containers, and dry bulk tonnage).

Consistent with the evolving federal freight initiatives, the State of California recently published a statewide Freight Mobility Action Plan (FMAP) in response to MAP-21. Adjustments to the FMAP will be coordinated with the new FAST Act to ensure compliance. Despite the national attention to freight planning and recent provisions for federal freight funding availability state and local public sector agencies remain challenged to effectively address all of the freight mobility and sustainability financing needs. Another 2015 freight development in the State of California was the Issuance of Executive Order B-32-15 (EO), this EO mandated several state agencies, including Caltrans and the California Air Resources Board (among others), to jointly develop a Sustainable Freight Strategy. SANDAG has been active in the development and implementation of this EO in conjunction with the FAST Act freight provisions and the FMAP.

San Diego and Imperial Counties have had access to federal Coordinated Border Infrastructure Improvement funds, but not enough to address all of the border freight needs in the region. Similarly, there are no federal funds targeted directly at port landside access improvements. Starting in 2009, the Federal TIGER¹ discretionary grant program has made some awards to freight-related projects, but it is not assured of continuing beyond the last (6th round) of 2014. In 2007, the State of California created a dedicated bond bill in order to fund freight projects; it is called the Trade Corridor Improvement Funding (TCIF) program. As of 2014, the program resulted in programming of over \$250 million in the San Diego Border Region for port access, border highway improvements, and rail projects. While TCIF was a large down payment on the massive freight needs throughout the state, there is no current evidence that the State of California will undertake another bond bill like TCIF to provide further funding.

Local public agencies that tackle large scale freight projects must overcome inherent challenges of funding sources, funding priorities, and the need to develop unique funding partnerships.

Although freight transportation stakeholders have advanced projects and proposals to enhance freight mobility by building new infrastructure and increasing system efficiency, public planners face several challenges when advancing public freight improvement projects.

These challenges include competition from non-freight projects for public funds, limited community support in the freight planning process, building consensus among various government entities and private sector stakeholders, land use challenges, and limited or restricted availability of funds

¹ TIGER is the U.S. Transportation Investment Generating Economic Recovery discretionary grant program, administered by the U.S. Department of Transportation with its continuation and funding levels set by Congress.

available for freight transportation. It is in federal funding where the remaining challenges are perhaps the greatest.

4.2 Market Issues Impacting Freight

4.2.1 Changing Market Conditions and Supply Chain Drivers

Public agencies planning and financing complex freight projects work with limited influence over the freight demands and needs they are trying to help meet. This is because freight demands are almost entirely market driven and because the performance and character of the local economy is a primary factor in the demand for freight. Public agencies planning freight projects need to monitor and understand varied market issues around the evolution of supply chain management, including product sourcing, distribution network operations, and mode choice decision-making. For instance, as a result of the relative shifts in total delivered costs following the Great Recession in 2009, shippers have re-examined sourcing practices to optimize their supply chains, reduce risk, and add flexibility to their supply chains. In some cases, this is resulting in U.S. manufacturers reconfiguring their supply chains to move plant operations and sourcing suppliers closer to home or elsewhere within Asia, because of free trade agreements, lower North American energy costs, exchange rate shifts, and rising labor and production costs in Asia. Mexico has increased its share of U.S. imports, as China appears to have peaked as a source country for manufactured goods. U.S. Census Foreign Trade Statistics reported growth of 5.3 percent in the value of U.S. goods imported from Mexico in 2014 over 2013.

There are skeptics that the increases in delivered costs from China will result in a concentrated shift of U.S. sourcing to Mexico (referred to as 'near-sourcing'), but there is no question Mexico has increasingly attracted foreign investment in manufacturing for the North American market, and for export to the U.S. market in particular. There are others who point to additional emerging factors that suggest a more profound, long-term change in supply chain strategy. This thinking holds that the massive outsourcing to China over the past 20 years represented a single-minded goal of achieving only the lowest-cost manufacturing. Now the evidence is the pendulum is swinging toward a more sophisticated and complex supply chain management paradigm, one that is prompting major shifts in where goods are manufactured, taking into account supply chain risk and the value of time-to-market embedded in calculations of total delivered cost. This is an area for constant monitoring for regional planning agencies in San Diego and Imperial counties, due to the great importance of crossborder trade.

Optimizing around these supply chain management objectives incorporates a variety of additional factors, including transportation costs, environmental footprint, security costs, currency fluctuations, inventory costs, and the cost of credit and risks of supply chain disruption. For producers, shippers, and carriers, this approach incorporates the value of diversification of supply sources to mitigate risk from various suppliers. It also increases the emphasis on flexibility and responsiveness of the supply chain because demand forecasting has become more difficult, especially for those goods sold through multiple channels including eCommerce where consumer behavior in use of

'Omnichannel'² retailing is still evolving. When all those issues are considered, manufacturers may conclude that Mexico or some other near source location is preferable to Asian-country sources. A broader view of supply chain strategy has people thinking in terms of best-cost sourcing. This means looking at labor rates, but also other supply chain metrics such as worker productivity, production quality, transportation alternatives, emissions footprint, inventory costs, and improved speed and savings available from near-sourcing in Mexico.

4.3 Regulatory Issues Impacting Freight

There are many aspects of freight transportation system operations affected by regulation by government agencies. Among the regulatory issues are U.S. DOT regulations affecting Mexican truck access and truck safety, and regulations affecting freight emissions. There are a broad range of national level transportation regulations affecting equipment and their operators, most all of which affect available capacity of the system. The regulatory environment has been especially challenging for trucking, where changes to hours of service, driving record and driver health testing have combined to reduce the available driver capacity. There are regulations imposed on trucking at the state and local levels of government as well, each with different ranges of impacts.

4.3.1 National: U.S. Department of Transportation Mexican Trucking Regulations

Expanded access to the U.S. market for Mexican trucks has remained an unresolved issue since 1994. This has been one of the most contentious U.S. transportation policy issues for 20 years despite having been required by the North American Free Trade Agreement (NAFTA). Currently, this issue remains difficult for planners to account for despite there being a recently-completed pilot program for qualified Mexican truckers to gain access to the U.S. market. Following completion after three years, the latest pilot program had extremely limited participation by Mexican trucking companies, and the planned statistical evaluation of safety performance has been called into question because just two Mexican motor carriers accounted for 90 percent of the border crossing and 80 percent of the associated inspections under the program.³ There remains the threat of renewed retaliatory tariffs on U.S. exports applied by Mexico for the United States failure to comply with the terms of NAFTA for trucking access. Despite the good safety performance of the participating carriers approved for operations, it is not clear to either proponents of permanent adoption of the program or the continued opponents of Mexican truck access what the U.S. DOT will ultimately do beyond granting permanent operating authority to the few participating Mexican motor carriers. The advocates of permanent adoption of the program cite the positive safety performance by qualifying Mexican trucking companies as evidence the program can assure safe operations while delivering improvements to crossborder supply chain operations. Opponents still say truck safety is an unresolved concern and a threat to U.S. truck driving jobs. The future of Mexican truck access may

² Omnichannel retailing is using eCommerce, physical stores, call centers, and direct-to-home or direct-to-residential delivery in combination by the same retailer, in attempts to capture purchasing behavior through all available retail channels at the same time.

³ According to Federal Motor Carrier Safety Administration, in the recently-completed 3-year pilot program, just one Mexican carrier accounted for well more than half the border crossings. That carrier had 30 trucks in the program (out of 55 total trucks across all carriers operating in the program) with the Otay Mesa Port of Entry accounting for more than 75 percent of the crossings during the program across the entire U.S./Mexican border. These crossings were almost entirely to deliver auto parts to a location within San Diego, within the border commercial zone and; therefore, not representative of overall U.S./Mexico trade by truck.

depend on what the Mexican government does with the United States still not in full compliance with the terms of the original NAFTA accord.

The outcome of this policy issue can impact crossborder traffic in San Diego because apart from the pilot program, U.S. regulations limit most Mexican trucks to only entering a 30-mile commercial zone along the border. If the program use was expanded, the current crossborder truck traffic (called Mule services due to the constant back and forth haulage in and out of the 30-mile zone) could shift over time.

The right of Mexican trucks to operate in the United States was negotiated by President Bush and enacted into the NAFTA treaty under President Clinton and approved by the U.S. Senate. NAFTA includes provisions governing crossborder trucking between United States, Canada, and Mexico that would have allowed Mexican carriers to fully provide cross-boundary trucking services to the United States by January 1, 2001. Certain restrictions on the rights of Mexican nationals to invest in U.S. domestic trucking companies providing international cargo services between points in the United States also were scheduled to be phased out by the end of 1995. However, responding to interest group pressures, the Clinton and Obama Administrations have both cited outstanding safety concerns in the delays in implementing the treaty provisions. There were separate agreements in NAFTA to coordinate truck size and weight regulations between United States, Canada, and Mexico that have not been implemented either, though there has been less political (or economic) pressure to do so.

There is a long-standing alternative available to trucking companies wanting to operate on both sides of the border, which is to register trucks in both Mexico and California. This 'dual plating' operation incurs higher costs as motor carriers must pay for registration in two states at the same time, and are subject to laws and regulation on both sides of the border, but it is an alternative that pre-dated NAFTA and continues today. The use of this alternative makes the cost of crossborder trucking more expensive ultimately raising the cost of crossborder trade yet may continue to be the practical alternative until the original NAFTA harmonization of crossborder trucking is achieved.

4.3.2 State: California Air Resources Board Regulations

The State of California, with the help of affected industries and other interested parties, has long been advancing policies and programs to incrementally reduce congestion and to address the environmental impacts resulting from goods movement in California. The program is extensive and includes regulations and incentives including the following:

- Proposition 1B – Goods Movement Emission Reduction Program – the five-year-old partnership between the Air Resource Board (ARB) and local agencies (e.g., air districts, ports, and transportation agencies) has already substantially reduced air pollution emissions and health risk from freight movement along California's trade corridors. Local agencies provided financial incentives to owners of equipment used in freight movement to upgrade to cleaner technology.
- Goods Movement Planning – California state agencies including Caltrans and the California Environmental Protection Agency (EPA) brought stakeholders together to discuss and address goods movement and the reduction of their environmental impacts in California.

- Port Activities – In an effort to reduce emissions for port-related sources, ARB has pursued regulatory activity on cargo handling, commercial harbor craft, port trucks, ship auxiliary and main engines, on-board incineration, shore power, and vessel speed reduction. ARB developed Health Risk Assessments for the Ports of Los Angeles, the Port of Long Beach, and the Port of Oakland used in measuring impacts of emissions reduction efforts.
- Rail Yard Activities – these efforts include agreements with Union Pacific and Burlington Northern Santa Fe (BNSF) Railways to reduce locomotive emissions near rail yards and the development of new regulations to address on- and off-road vehicles at rail yards. The ARB approves major rail equipment fleet rules.
- Truck Retrofitting and Replacement – ARB’s detailed 2009 rules requiring retrofit or replacement of virtually the entire fleet of trucks operating in California plus mandated tire and aerodynamic-related specifications has been successful in reducing emissions. The statewide bus and truck rules required fleet owners to replace trucks operating in California or retrofit them with diesel exhaust filters by 2014. There is a remaining requirement that owners replace engines older than the 2010 model year under an implementation schedule running through 2022.

California freight warehouses and transportation companies are facing aggressive environmental regulations, which can influence supply chain decisions. Clearly, these programs need to be understood and monitored by those planning freight projects as they impact market competitiveness and prices to move freight around California.

Since the California freight regulations are more stringent than in other states, monitoring regulatory impacts and possible impacts to freight volumes moving in the state remain a challenge. Looking forward, the state focus is increasingly on reducing carbon from the freight supply chain. California, in the 1990s, was the center of efforts to reduce pollutants such as nitrogen oxide (NOx), sulfur oxide (SOx) and particulate matter (PM). NOx, SOx and PMs present health risks such as respiratory illnesses and cancer, while carbon dioxide emissions are associated with greenhouse gas (GHG) emissions contributing to global climate change.

California regulations are now increasingly focused on the reduction of GHG emissions and carbon footprints. The importance of transportation activity to the states’ carbon footprint has made supply chains a primary target in California's carbon emission regulatory efforts.

The 2006 Global Warming Solutions Act, or Assembly Bill 32 (Nunez, 2009) as it is known, continues in force providing deadlines for progressively stricter reductions in carbon emissions from every aspect of a company's operations. By 2020, California emissions must be rolled back to 1990 levels. The state also has a goal of reducing carbon emissions to 80 percent below 1990 levels by 2050, as reflected in Executive Order S-3-05 and Governor Brown’s Executive Order B-16-2012 (which is specific to the transportation sector).

California regulators intend to reach these emissions reduction goals primarily by reducing vehicle miles traveled, improving fuel efficiency in all modes of transportation, and burning cleaner fuel. For example, ARB implemented a timeline for replacing older trucks with 2007 and younger model trucks. Trailers are affected by regulations that follow the EPA’s SmartWay guidelines for increased fuel mileage performance. EPA's guidelines include low-resistance tires and more aerodynamic

trailers. They are voluntary under the Federal EPA SmartWay Program, but these measures are mandatory in California. Out-of-state trucks, as well as trucks that enter the state from Mexico and Canada, are subject to California's regulations for trucks and domestic 53-foot trailers.

Another dimension to California's emissions reductions efforts is the move to vehicles having no net increase in emissions. The state first introduced a Zero Emissions Vehicle Program back in 1990 for passenger and light-trucks initially. Modified several times subsequently, the no-net increase target for emissions remains an element of state vehicle emissions policy to meet the California's long-term emission reduction goals. The policy requires manufacturers to offer for sale specific numbers of the cleanest propulsion technologies available, which include: battery electric, fuel cell, and plug-in hybrid electric vehicles. Due to technological challenges originally, heavy-duty trucks were not the initial focus for these vehicle emission regulations. More recently, ARB is moving forward with plans for advancing regulations for no net increase in emissions from heavy-duty vehicles. ARB is looking to new standards where natural gas (NG) trucks will likely have to be deployed in large numbers, and hybrid electric vehicles will begin to be used more commonly.

Heavy-duty vehicle fleet regulations increase costs of equipment and can create infrastructure challenges for new fuel facility locations or the re-working of trucking networks to address limits on vehicle range or power.

Warehouses and distribution centers are also affected by state environmental regulations. Regulations mandate more efficient lighting, a move to electric forklifts, and other energy reduction measures. Southern California, with over 1.5 billion square feet of industrial real estate, is by far the largest distribution complex in the country and substantial investment is being made to improve the energy profile of this sector.

ARB introduced a Sustainable Freight Plan in 2014 (finalized in 2015) with the intention of producing a freight system that meets national air quality standards, meets long-term climate change goals for 2050, integrates with state energy policy, and maintains freight competitiveness. This includes a future vision, in which technology, system-wide efforts, and stakeholder engagement are the three components to a long-term sustainable freight plan for California. Their regulatory program for freight will be intended to achieve sustainable freight objectives in the future.

4.3.3 State: California Sustainable Community Strategies Planning Requirements

Beyond California's air quality regulatory policy, there is a broader shift in state law toward implementation of steps toward environmental sustainability in planning, integrating transportation as one element of sustainable communities.

A step towards encouraging more sustainable communities, state Senate Bill 375 (Steinberg, 2008) (SB 375) requires each major metropolitan area in the state to align transportation, housing, and land use plans for their region. Among the requirements affecting transportation, the Metropolitan Planning Organization for each metropolitan area, such as SANDAG for San Diego, is to prepare a Sustainable Communities Strategy (SCS) that demonstrates how the region will meet per capita GHG emission reduction targets for passenger and light-duty trucks in the region set by ARB. While SB 375 does not focus on goods movement, it could have a substantial impact on freight transportation and international trade. A challenge for regional SCS development is to adequately address urban freight needs in the community planning strategies to be adopted. Common SCS approaches such as reducing building footprints, use of dense in-fill redevelopment, increased space devoted to pedestrian and bicycle transit all provide challenges for urban goods movement activity. If adopted without appropriate consideration for urban goods movement, these strategies risk congestion, increased emissions, increased noise, higher energy consumption, and greater crash risks for goods movement activity. This would be primarily from trucks including their interaction with passenger vehicles, cyclists, and pedestrians.

4.3.4 Local: Land Use Conflicts and Land Use Availability for Freight

With the San Diego region's population expected to grow from 3 million to over 4 million by 2050, it also is expected that there will be a further decrease in supply of available industrial land and that the continued gentrification of commercial and industrial lands will exacerbate land use conflicts between freight and non-freight uses. Industrial land uses may be pushed out of the urban core areas accompanied by negative transport system and environmental impacts. This is likely to be most acute for the Port of San Diego operations which are located along the region's working waterfront area as well as the downtown rail yard for BNSF railway. Additionally, land use conflicts are emerging in the border region now, as the southern part of the county continues to develop.

In addition to land use conflicts, land use availability, land use cost for freight projects, and land use prices will likely present major challenges for freight facilities, especially in coastal San Diego County. The region continues to grapple with "not in my back yard" (NIMBY) issues related to existing and new freight projects. To compound the land use conflict and land price issues, currently there are inadequate land use regulatory protections for freight and freight-related facility land use. As freight-related facilities get driven away from the urban core, which is also the commodity consuming core of a region, the phenomena of freight sprawl already observed can increase. If freight facilities were put out of business or moved away from consumers, then additional truck miles can be expected so that goods can be delivered to consumers and businesses remaining in the region.

4.4 International Developments Impacting Freight

With the importance of international trade to the economy and freight demand of San Diego, international developments are of great and increasing importance to the future of the region. Among these are such once-in-a-lifetime events such as the expansion of the Panama Canal as well as evolutions of transportation systems for railroads and ports in North America.

4.4.1 Expansion of Panama Canal

The Panama Canal expansion project was completed and opened for operation in June 2016. The new third set of locks, will allow the canal to handle container ships with nominal capacities of up to about 13,000 20-foot equivalent container units (TEUs), more than double the approximately 5,000 TEUs capacity ships that are now the largest that can fit through the current locks (called 'Panamax' size ships). The prospect of the expansion of the Panama Canal has long drawn attention to potential for diversion from California and Mexican Pacific ports, particularly the Ports of Los Angeles and Long Beach. There remains the potential for Panama Canal shipping routes to affect the need for expansion in Southern California or alternative ports in Mexico. Shifts to follow the expansion are not clear at this time, but several possible shifts will require monitoring. Among these shifts could be diversion of additional freight originating or destined for the Eastern portion of the United States, potential increases in Southern California port trade with the East Coast of Latin America, and/or potential increases in sea cargo handled by Baja California ports such as Ensenada. From these sea trade shifts there could be impacts to crossborder truck traffic; or even more significantly consequences from consequential changes in global sourcing and shipping routes that could impact the growth forecast for cargos moving through California ports, thereby further altering supply chain patterns as we know them today.

During the course of the Panama Canal expansion project over the last six years, the prospects for significant additional shifts in trade to Panama Canal routes have diminished. Manufacturers and retailers have already largely adjusted their shipping practices, taking advantage of existing vessel services through the Panama Canal as well as alternative routes such as shipping from Asia to the Eastern United States via the Suez Canal. Some of these adjustments to shipping practices were seen during the 2014-2015 U.S. West Coast container port congestion, when shippers used alternative gateway ports on the East Coast, or in Canada and Mexico.

Another aspect of the Panama Canal expansion is on the world vessel fleet and the port infrastructure serving those vessels. In the time since the expansion was approved by Panama a decade ago, ocean carriers and large container ports have continued to invest in larger capacity. The carriers and the ports that service them have not constrained themselves to the capacity constraints of the expanded Canal. On the vessel side, as of 2014, Lloyds List Intelligence reports that there are already over 150 container ships in the world fleet that are over 13,000 TEU in capacity, including some operating on transpacific routes from Asia. These are ships that are already larger than will fit through the unfinished new locks of the Panama Canal, or 'New Post-Panamax' size. There are more than an additional 100 of these size vessels on order, adding to share of world container fleet capacity unable to use the newly expanded Canal. These ships will be used increasingly on transpacific trade routes, being 'cascaded' into Asia-U.S. trades following introduction of the largest current 19,000 TEU vessels⁴ into the Asia – Europe trade routes.

The changing economics of ocean shipping provided by larger ships, and the large port terminals and infrastructure needed to handle the surges of cargo that accompany these large ship calls are challenging the Southern California Ports of Los Angeles and Long Beach as behemoths of North American ocean trade. Challenges with U.S. port labor and port terminal productivity remain, but it

⁴ Additional increases in the maximum capacity of newly ordered containerships to 20,000 TEU are reported and designs for 22,000 TEU capacity container ships are already being marketed by Asian shipyards, showing no end to the industry trend towards even-larger ships.

is unlikely that those obstacles will outweigh the concentration of container trade in the large vessels calling the large ports that can handle them. The Panama Canal expansion, most likely, will have at most a moderate additional impact on waterborne trade in the Port of San Diego.

4.4.2 Intermodal Rail Service Growth

The North American intermodal rail business is continuing to receive investment totaling billions of dollars from the Class 1 railroads. Overtaking coal shipping, the intermodal rail business is now the largest business segment for the railroads and; therefore, the most important for the railroads going forward. The rail system investment is an international one across Mexico, United States, and Canada, with substantial growth in north-south intermodal traffic lanes, avoiding border trucking issues and adding security while reducing costs. The influence on San Diego from the growth in international intermodal rail service is indirect for two reasons: there currently is no significant crossborder intermodal rail service between Baja California and the United States, and the Port of San Diego is not a large container port that requires intermodal rail service. Factories in Central Mexico linked to the U.S. market by efficient rail service can be more competitive than border factories, such as those in Baja California, which is still dependent on crossborder truck service for their freight needs. Continued north-south intermodal rail system investment to the east (Texas in particular) may grow cross border trade by rail faster than the Baja California-located production which moves by truck. This is due to the geography of production in Baja California where the distance south of the border is less than 100 miles. The Desert Line rail route is often cited as a route to grow Baja California rail traffic moving eastward, with private interests suggesting that they will rehabilitate the line. In spite of freight rail economics generally more favorable for rail to be able to compete with truck over longer-distances, the relatively close proximity of the Maquiladoras in Baja California make such rail service competing with truck more challenging. Ultimately, market forces will determine if and when such freight rail becomes a viable crossborder option for freight.

Limitations on U.S./Mexican rail capacity have another potential impact, already seen in the auto manufacturing business which are finished vehicles made in Mexico being shipped by vessel to U.S. ports, instead of using capacity-constrained north-south rail. It is likely there will be opportunities for existing auto handling ports, such as the Port of San Diego to capture some of the growing U.S./Mexican vehicle trade, at least in the medium-term, because most Mexican auto production is now in Central Mexico and the distances are long enough to make the ocean shipping cost competitive. Longer term, the cost and speed of the international intermodal rail service will be preferred by shippers for most manufactured products from Central Mexico where the shipping distances can justify use of rail service.

4.4.3 Port Developments in Baja California

Prior to the Great Recession, Mexico had advanced plans for port development on its Pacific Coast. The sharp decline in transpacific trade during the recession and then the weak recovery in the trade that followed changed the potential outlook for those ports. The global financial market environment for private sector investment in ports also became much more difficult with significant reduction in the available private capital for developing country port investments. In combination with an accelerated pace of change in the global container industry, the prospects for major development of ports in Baja California changed. The long-term potential geographically for a Baja

California, Mexico port to serve some of the U.S. market remains, but the likelihood of this happening within even a medium-term planning horizon is diminished.

Mexico as a location for distribution centers and warehouses, remains increasingly important, especially in Central Mexico in service to the domestic Mexican market. In Baja California, the role of distribution centers and warehousing is to serve the smaller regional population as well as the growing manufacturing-for-export. Much of the domestic Mexican distribution and warehousing is now served for international ocean trade through Mexico's seaports of Lazaro Cardenas, Manzanillo, and Veracruz. The Mexican port of Ensenada remains as an existing alternative gateway into the U.S. market. Capturing just a slice of the substantial U.S. import trade would be a boon to smaller ports such as Ensenada. However, the previous plans in Mexico to develop a Baja California container port at Punta Colonet are effectively on hold. So current logic suggests that if we look for significant port growth that could impact the San Diego freight network, we would want to closely watch growth at the Port of Ensenada. The opportunities for Mexican ports to serve U.S. trade may have increased due to potential shipper reactions to the 2014-2015 container port congestion in the Southern California ports. After years of adequate performance in handling the post-recession pace of ocean trade growth, a combination of operational factors resulted in severe congestion, delaying ships and cargo and disrupting trade. The Baja California ports were not used as significant alternative overflow ports for California ports, but if congestion problems linger, the potential interest in the Mexican ports for handling U.S. trade could be renewed. Conversely, if adequate performance of the Southern California ports is restored, it will add competitive pressure on Mexican ports serving Baja California, with the potential for transshipment⁵ by truck across the California border into Baja California.

From a North American perspective, there are now competitor ports to Southern California serving the U.S. Midwest through British Columbia in Canada and through the U.S. East Coast ports served by Suez-route vessel services from Asia connected with improved East-West intermodal rail connections into the Mid-West. The prospect of Baja California ports being viable as needed capacity additions to the Southern California ports has been diminished by the advances made by these other gateways in serving North American sea trade.

The acceleration in the container shipping industry moving to larger capacity vessels since the Great Recession adds to the challenges faced by Baja California ports becoming viable U.S. container port gateways for California. Container lines have quickly introduced ever-larger vessels into the transpacific trade, shifting from vessels of 8,000-TEU capacity to those with 10,000-TEU and now 12,500-TEU and even 14,000 TEU of capacity. In theory, these very large container ships (VLCs) can be today physically handled at key U.S. West Coast port terminals having the large cranes, deep berths, and land-side terminal space requirements these vessels require. If port terminal and port trucking operational challenges can be overcome, the VLCs make competition by smaller ports or new ports more difficult. As these large vessels have replaced strings of smaller vessels, the lower operating costs and potential for lower rates has seen a re-concentration of market share into the

⁵ Dictionary of International Trade definition: "The transfer of merchandise from the country-of-origin to an intermediary country prior to shipment to the destination country for purposes of 1) achieving a lower transportation cost, 2) legally or illegally achieving new country of origin status for the merchandise, or 3) circumventing the foreign trade policies of the country of origin or the country of destination."

few ports that are handling these large ships. This has also had the impact of raising the bar for entry into the market for new competitive container services via the ports in Baja California.

Central Mexican port planners have continued development projects, but with the understanding and strategy of leveraging Mexico's lower costs for land, labor, and inland transport in handling Mexican trade. The Port of Lazaro Cardenas is still promoting its Kansas City Southern Railroad connection to the U.S. heartland, but the rail route into the United States has not gained traction in the market for transshipped cargo. Instead the success of these Mexican ports has been in serving the growing Mexican ocean trade, some of which is trade in components shipped into or out of central Mexico for use in manufacturing, such as for automobiles. There is not the equivalent growth in the Mexican manufacturing trade through the Port of Ensenada, likely because of the proximity to the large number of vessel services calling⁶ the Southern California ports and the option to handle that trade via truck crossborder through San Diego.

4.4.4 Port of San Diego Issues

The international and domestic marine cargo operations at the San Diego Unified Port District (Port) face continued pressures due to the proximity of the marine terminals to other commercial waterfront property and issues such as gentrification.

The port is a public benefit corporation and special district government entity that was created in 1962 by an act of the California state legislature. The Port manages San Diego harbor and administers the public lands along San Diego Bay.

The Port owns and operates two industrial marine cargo terminals on San Diego Bay.⁷ These terminals, the Tenth Avenue Marine Terminal (TAMT) and the National City Marine Terminal (NCMT), serve as regional marine cargo facilities.

The Port is a specialized niche port which handles automobiles, containerized cargo (primarily fruit imported by Dole Fresh Fruit), break-bulk cargo, military cargo, oversized wind energy cargo, steel (primarily used by National Steel and Shipbuilding Company - NASSCO), forest products, fertilizer, dry bulk

Figure 4.2 TAMT with Downtown San Diego in Background



Source: City of San Diego

⁶ Dictionary of International Trade definition: "A port at which a vessel loads or unloads some or all of its cargo or passengers during a voyage."

⁷ The San Diego Unified Port District also operates two maritime cruise passenger shipping facilities, B Street and Broadway Pier, which include the servicing and loading of supplies for the cruise ships when calling on San Diego.

cargo such as sand and cement, and petroleum products (primarily used by the San Diego International Airport and the cruise ship industry).

There has been a focused effort to improve the operations of the port's TAMT, and a TAMT Optimization Plan is being implemented by the Port. The intent of these improvements has included adoption of a strategy to produce sustainable benefits. Like in other historic port cities, the Port has grappled with urban gentrification pressures, due to their historic locations on the waterfront in the urban core. Ports were in place first and cities grew up around the Port operations, producing today's gentrification pressures. TAMT in particular, is a case study in urban gentrification, with TAMT located on some of the most valuable waterfront property in the country. Due to the terminal's strategic location and the large fixed capital investment already made, prudent management has dictated that port investment in sustainable in-terminal operational improvements is a key strategy. In addition to serving as a key element of the region's freight transportation system, it also provides for military responsiveness and readiness and as an economic driver for the local, state, and national economy.

Sustainable port strategy at TAMT has led to the port pursuing two initiatives for the terminal: one is optimizing internal terminal cargo operations so that more rail traffic can be accommodated and so that the community will experience less truck traffic; the other is to explore options to develop Marine Highway connections to the terminal. Marine Highway cargo vessel operations serving TAMT have the potential to reduce local truck traffic by shifting some cargo to water from highway for transportation in and out of San Diego. The cargo optimization objective requires demolition of dockside sheds which will maximize cargo layout areas and promote in-terminal rail car loading for both commercial and military cargo needs.

The TAMT Planning District is a developed, marine-related industrial area that directly abuts Barrio Logan. This proximity is an issue because this community is considered a "Community of Concern" for San Diego.

Currently, in the TAMT Planning District the tidelands and uplands of this industrial area provide over 40,000 jobs.⁸ These jobs are important in the region's economy. More important, this is the only area in the San Diego region providing established waterfront industrial sites with railroad service, freeway access nearby, commercial port-related support functions, and deep water berthing. The existing water depth of 42 feet near the marine terminal and 35 feet in the industrial area would be expensive and very difficult to replace elsewhere, so optimizing existing marine cargo operations is critical to the region.

⁸ Source: San Diego Unified Port District

APPENDIX A: FREIGHT GATEWAY STUDY UPDATE TECHNICAL MEMORANDUM

This technical memorandum for the Freight Gateway Study Update documents data sources, forecast sources, and references to freight flows used in the update. The material is organized separately for the baseline historic commodity freight flow data and the forecasts.

Updated Gateway Region Historic Commodity Flow Base Year Data

For the most comprehensive publicly available coverage of freight activity, the U.S. Department of Transportation's (U.S. DOT) multimodal Freight Analysis Framework (FAF) has been used as the default source of historic data in the Freight Gateway Study Update project. The FAF is published by the U.S. DOT, Federal Highway Administration (FHWA). This annual data covers multimodal freight flows, domestic and international, of the United States, with commodity and origin and destination (O/D) region detail. This is the most comprehensive and frequently-used public freight flow data source used in public sector planning around the country. The current version is referred to by the FHWA as FAF. Every five years, the FHWA releases annual updates. Of these updates, version 4 of the FAF is the latest and the primary freight flow data source used in this update study.

The FAF data is annual frequency data, whose foundation is the U.S. Commodity Flow Survey (CFS), conducted by the U.S. Census Bureau as part of the U.S. Economic Census every five years. The O/D geographic detail in the CFS is reflected in the FAF, with major metropolitan regions reported as a whole, and the remainder of each state having flows aggregated into regions. O/Ds include a total of 132 FAF regions for U.S. domestic flows, and eight foreign regions (including Mexico, for imports and exports). San Diego County is its own CFS region and, consequently, also its own region in the FAF. The FAF does not include information on the O/D, or routing of movements below the county level. Therefore, the data covers San Diego domestic and international freight flows by O/D with other metropolitan areas and/or other state areas in the country. Flows originating or destined for Imperial County are not available at the county level in the FAF, but are included in a broader "remainder of state" region. Thus, for Imperial County, the FAF does not provide domestic freight flows by origin and destination in Imperial County with other metropolitan areas and/or other state areas in the country. However, when considering the truck and rail modes, specific Imperial County freight flows can be derived between Mexico at land port of entry border crossings and other metropolitan areas and/or other state areas in the country. Figure A.1 has the U.S. FAF zone map, with San Diego and Rest of State of California indicated.

Figure A.1: U.S. Department of Transportation Freight Analysis Framework Region Zone Map

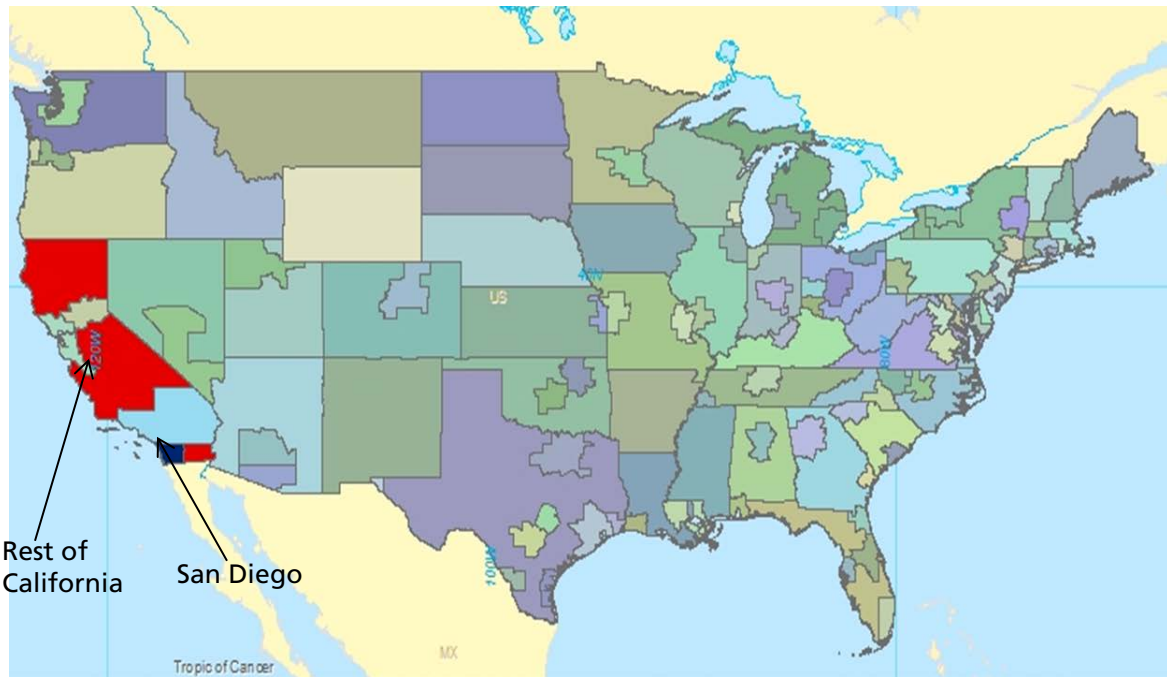

Source: FAF version 4

For purposes of comparison across transportation modes, the FAF data is measured in short tons and dollar value. This means units of equipment, such as the numbers of trucks, rail cars, aircraft, or vessels, whether loaded or empty, are not provided in the FAF data. In truck traffic data, such as from Caltrans, the truck types can include varying sizes (two axle, three axle, five axle, etc.) that carry different quantities (weight in tons) of cargo. Furthermore, five axle tractor trailer trucks can carry 20', 40', 45', 48', or 53' containers of varying weights. For each category of container dimension, there are multiple routes possible for truck drivers between O/Ds, as they relate to San Diego and Imperial counties. Due to these routing uncertainties, truck flow data has not been assigned to specific road segments.

The initial objective of the study was to utilize the FAF freight flow data throughout the development of the freight gateway forecasts including the base year and forecast information. As a means to validate and supplement the FAF data, other public historic data sources have been used to improve upon the detail available for individual modes and geography of FAF freight flows. Where base year discrepancies between data sources exist, other historic data sources were relied upon when footnoted in the Gateway Tables.

These other data sources are summarized in Appendix Table A.1. In this table, the organizational source for the data is listed in the first column with the common name for the data set in the second column. In the first section of the table, the third column provides a short description of the data available. In the second section of the table, there are columns for the dimensions of the data available including volume and value units and commodity classifications, O/Ds of commodity flows, measures of the economy in Gross Domestic Product (GDP) terms, the commodity classification used when there is commodity detail, and the years(s) used from what is available for each source. The commodity classifications references with abbreviations are the Harmonized Tariff System (HTS), the Standard Classification of Transported Goods (SCTG), the Standard Transportation Commodity

Classification (STCC), and the Waterborne Commerce Statistics Code (WCSC). The sources for the data are listed in the Sources and References citations listed at the end of this Appendix.

Table A.1: Historic Commodity Data Sources Overview

Source Organization	Data Name	Data Description
U.S. Army Corps of Engineers (ACE)	Port tonnages	Annual tons, by commodity, by port, from Waterborne Commerce statistics
U.S. ACE	Tonnages by lane	State to state, and state to export, by commodity, from Waterborne Commerce statistics
U.S. Customs and Border Protection (CBP)	Rail border crossing data	Carloads & trains crossed, by border crossing (San Ysidro, Tecate, Mexicali)
U.S. CBP	Truck border crossing data	Containers & trucks crossed by border crossing (Otay Mesa, Tecate, Mexicali)
U.S. DOT Bureau of Transportation Statistics (BTS)	Transborder freight	Commodity (HTS classification) value for rail, by border crossing (San Ysidro, Tecate, Mexicali)
U.S. DOT BTS	Transborder freight	Commodity (HTS classification) value for truck, by border crossing (Otay Mesa, Tecate, Mexicali)
U.S. DOT FHWA	FAF	Commodity (O/D by state); volume & value for rail
U.S. DOT FHWA	FAF ³	Commodity (O/D by state); volume & value for truck
U.S. Surface Transportation Board	Waybill sample	Rail tons, carloads, & commodity (STCC classification) by business economic area region
Caltrans	Truck Average Annual Daily Truck (AADT)	Average annual daily truck volume by truck type
U.S. Bureau of Economic Analysis	Regional GDP	GDP by metro area, by industry sector (North American Industry Classification System (NAICS) (San Diego, Los Angeles, Riverside)
U.S. Census Bureau	Manufacturing Census	Manufacturing facility, employment, & value added by NAICS classification (San Diego, Los Angeles, Riverside)
U.S. Census Bureau	Wholesale Census	Wholesaler facility, employment, & value added by NAICS (San Diego, Los Angeles, Riverside)
U.S. Census Bureau	Transportation Census	Transportation & distribution facility, employment, & value added by NAICS (San Diego, Los Angeles, Riverside)
U.S. Census Bureau	U.S. Trade Online Data	Commodity Harmonized System, in value and volume, by customs district and trade partner country

Table A.2: Historic Data Source Concept Coverage and Timeframes

Organization Source	Data Name	Volume	Value	Commodity	O/D	GDP	Commodity Classification	History
U.S. ACE	Port Tonnage	X		X			WCSC	2007 2012
U.S. ACE	Tonnage by lane	X		X			WCSC	2007 2012
U.S. CBP	Rail crossing data	X						2007 2012
U.S. CBP	Truck crossing data	X						2007 2012
BTS	Trans-border freight		X	X			HTS	2007 2012
BTS	Trans-border freight		X	X			HTS	2007 2012
FHWA	FAF ³	X	X	X	X		SCTG	2007 2012 (est.)
FHWA	FAF ³	X	X	X	X		SCTG	2007 2012 (est.)
Surface Transportation Board	Rail waybill sample	X		X	X		STCC	2007 2012
Caltrans	Truck AADT	X						2007 2012
Bureau of Economic Analysis	Regional GDP					X		2007 2012
U.S. Census	Manu-facturing Census		X			X		2007
U.S. Census	Whole-sale Census					X		2007
U.S. Census	Trans- portation Census		X			X		2007
U.S. Census	U.S. Trade Online Data	X	X				HTS	2012

Updated Gateway Region Forecast Data

The primary source for the underlying forecast growth rates used in this update is the same as used for most of the historic flows, the FAF, version 4, from the U.S. FHWA. Use of these forecasts provides consistency because the FAF long-term commodity flow forecasts are available across transportation mode, geography, and commodity classification. No other publicly available freight flow data source provides this extensive coverage of U.S. freight flow activity.

This national modal freight commodity forecast database is updated every five years using a comprehensive set of historic freight statistical inputs. The FAF adds forecasts consistent with commodity flows by transport mode for domestic freight and international trade moving to, from, within, and through the United States. The import and export flows by commodity and mode are detailed by country/region trade partner including Mexico specifically. The freight forecasts are annual frequency with a long-term planning forecast horizon out to 2045. The models used in generating the FAF forecasts are macroeconomic, industry, and international commodity trade forecasts produced by commercial economic forecasters IHS from their economic, trade, and industry statistics databases and forecasting models on behalf of the U.S. DOT.

To produce forecasts to 2050 for this Freight Gateway Study Update, the growth rates forecast in the FAF from 2040-2045 were extended to the 2050 forecast horizon, with no adjustment to increase or decrease the growth rates for the last five years of the forecast period. The Gateway Tables, which are part of this study, contain the growth rates between the years 2012 and 2035, and the years 2035 and 2050. Tonnage and value in the FAF include the years 2012, 2035, and 2045 (the final year for FAF forecast). The forecast growth rates for this Freight Gateway Update Study were derived by using the FAF's future estimated tonnage and value for each of the years (2035 vs. 2012, then 2045 vs. 2040).

The Compounded Average Growth Rate (CAGR) used for each freight flow forecast in this study was determined for the years 2012 to 2035 by mathematically calculating the rate between the volumes for 2035 and 2012. For the years 2040 to 2045, the rate was determined and then applied out to the year 2050 to obtain the 2050 values. The CAGR for this forecast period was the same one obtained between the years 2040 to 2045.

The resulting freight and trade forecasts for the Gateway Border region capture the influences of regional industry growth, population, employment growth, and composition of trade growth. The forecasts assume no new interventions to affect traffic and they are unconstrained by infrastructure supply limits. This means they reflect a baseline of demand consistent with projected growth in the economy, but they do not reflect new policies, strategies, or programs that may come from ongoing regional planning processes. Not being a business plan forecast nor a development-potential forecast, other transportation forecasting analysis being conducted in the region, for other specific purposes and projects, may show different forecasts for traffic. That is appropriate where those analyses are attempting to estimate the impacts of changes to the system from alternative interventions contemplated to affect transportation activity in the forecast period. A consequence is that the Comprehensive Freight Gateway Study Update forecasts may underestimate potential future market share gains (and associated traffic) for San Diego and the Gateway Border region.

Updated Gateway Border Data

United States merchandise trade data from the U.S. Census Bureau provides more specific detail on crossborder commodities and value. U.S. Census' U.S.A. Trade Online data is an import database, which provides detail down to a ten-digit commodity code and provides volume in weight or units. This data was used to provide some detailed commodity information contained in the Freight Gateway Study Update.

Because Imperial County is grouped together with a geographic region in the FAF called Rest of California, specific domestic O/Ds for Imperial County were not able to be evaluated. However, any flow into and out of the Rest of California FAF zone to/from Mexico would have to cross through Imperial County. Therefore, border data for Imperial County for truck and rail was estimated using FAF by this method.

Updated Gateway Study Base Year Freight Flow Data

The following sections provide the methods utilized to generate base year data for each of the modes as they relate to the freight gateways in the San Diego and Imperial County regions. Where FAF data was determined to be inadequate, other sources were used to provide base year information. Each modal section includes specific details, tables, and explanations as to the particular method incorporated into the study.

Updated Border Modal Port of Entry Base Year Data

The FAF data for the U.S./Mexico border imports and exports are in tons. The U.S. DOT BTS publishes Transborder Data for Truck and Rail that reports the value and tonnage of U.S./Mexico trade monthly. The BTS data has been used where there were anomalies in the FAF data, such as for liquefied petroleum gas rail exports at San Ysidro. The U.S. CBP Agency also collects border crossing data measured in numbers of trucks, containers, and empty containers. This truck and rail border crossing count data is published by the U.S. BTS. Traffic and revenue studies for border crossings for trucks are based on truck counts rather than commodity flows in tons.

Updated Domestic Truck Base Year Data

In this Freight Gateway Study Update, there was a need to create a separate section to address the domestic truck flows within and to/from the region. This specifically illustrates the significant flow of trucks that circulate only in San Diego (those truck shipments not directly associated with a specific trade gateway). These truck flows had to be identified separately from those that flow domestically through San Diego, those that originate in San Diego and terminate domestically elsewhere, and those that terminate in San Diego and originate domestically elsewhere.

The process to estimate the different types of domestic truck flows is:

Internally circulating truck flows:

- Determine the tons/value from either inbound or outbound, single direction specific to the San Diego FAF zone only. This value represents internal truck circulation for San Diego County.

For inbound truck flows data:

- Determine total tons/value for domestic inbound to the San Diego FAF zone

For outbound truck flows data:

- Determine total tons/value for domestic outbound from the San Diego FAF zone

For through truck flows data:

- The only through truck traffic is predominantly from the flows to/from the Mexico border and the rest of the United States, excluding flows which originate/terminate in San Diego. Using FAF data that excluded the San Diego FAF zone provides this information for tons/value.

Updated Rail Base Year Data

Unlike the border, seaport and airport freight that have other public data sources to check against, the rail freight element in San Diego is reliant on FAF version 4. While the Burlington Northern Santa Fe railroad cargo volumes are published nationally, cargo volumes are not published with detail for the San Diego region.

However, there are some serious anomalies seen in the FAF version 4 for San Diego rail base year data. Some of these are substantial enough to make it difficult using FAF version 4 data for the base year as part of a published table in the Freight Gateway Study Update.

San Diego County rail traffic consists of four FAF version 4 components:

- Crossborder import/export (counted under San Ysidro rail)
- Crossborder import/export transferred to rail on the U.S. side of the border, such as from Toyota Motor Corporation (counted under Otay Mesa truck)
- Waterborne import export from the seaport transferred to rail such as by Pasha (counted under port)
- Domestic rail

Each of these elements is listed below and has discussion of the data issues associated with them.

1. Crossborder Rail (San Ysidro)

The crossborder rail can be validated by using BTS Transborder Freight (value), BTS Border Crossing Data (measured in units of rail carloads), and the U.S. Census Bureau U.S.A. Trade Online data.

Crossborder rail movements of freight at San Ysidro are entirely export-based with no inbound or imported rail loads. FAF underestimates freight volumes across the border, especially for liquefied petroleum gas (LPG). According to FAF, total export rail tons equate to almost 89,000 tons for the 2012 base year, which is equivalent to almost 1,110 carloads per year. Carloads per year can be calculated by using the CDM Smith/San Diego Freight Rail Consulting assumption of 80 tons per carload, which reflects an average carload weight.

Table A.3: 2012 and 2015 Rail Total Tons Exported to Mexico

FR_DEST	FR_OUTMODE	DMS_DEST	SCTG2	DMS_MODE	Total Ktons in 2012
Mexico	Rail	San Diego, CA MSA	Cereal grains	Rail	13.5915
Mexico	Rail	San Diego, CA MSA	Other ag prods.	Rail	0.4153
Mexico	Rail	San Diego, CA MSA	Animal feed	Rail	5.177
Mexico	Rail	San Diego, CA MSA	Milled grain prods.	Rail	6.9658
Mexico	Rail	San Diego, CA MSA	Other foodstuffs	Rail	7.8334
Mexico	Rail	San Diego, CA MSA	Alcoholic beverages	Rail	0.0665
Mexico	Rail	San Diego, CA MSA	Fuel oils	Rail	0.3388
Mexico	Rail	San Diego, CA MSA	Basic chemicals	Rail	0.0356
Mexico	Rail	San Diego, CA MSA	Pharmaceuticals	Rail	0.0559
Mexico	Rail	San Diego, CA MSA	Fertilizers	Rail	0.296
Mexico	Rail	San Diego, CA MSA	Chemical prods.	Rail	0.768
Mexico	Rail	San Diego, CA MSA	Plastics/rubber	Rail	31.4035
Mexico	Rail	San Diego, CA MSA	Wood prods.	Rail	6.5638
Mexico	Rail	San Diego, CA MSA	Newsprint/paper	Rail	5.6031
Mexico	Rail	San Diego, CA MSA	Textiles/leather	Rail	0.002
Mexico	Rail	San Diego, CA MSA	Nonmetal min. prods.	Rail	0.0333
Mexico	Rail	San Diego, CA MSA	Base metals	Rail	0.8104
Mexico	Rail	San Diego, CA MSA	Articles-base metal	Rail	0.5168
Mexico	Rail	San Diego, CA MSA	Machinery	Rail	0.2819
Mexico	Rail	San Diego, CA MSA	Electronics	Rail	0.2838
Mexico	Rail	San Diego, CA MSA	Precision instruments	Rail	0.0043
Mexico	Rail	San Diego, CA MSA	Waste/scrap	Rail	0.0424
				Totals	88.9109
				Carloads	1,110

Source: FAF version 4

The issue rests primarily with the FAF version 4 estimated volumes for Fuels oils (LPG). The volume of 340 tons is substantially underestimated. The tonnage volume is equivalent to about 4 rail cars. This indicates errors in volume for FAF version 4 for this rail freight segment.

The value can be cross-checked by using BTS Transborder Freight (value) and U.S.A. Trade Online. By determining the BTS proportional value of San Ysidro rail exports across modes and determining the U.S.A. Trade Online barrels (bbls) of LPG, the number of resulting rail cars to San Ysidro can be compared. This comparison is seen in the Tables A.4 and A.5 below.

Table A.4: 2012 Petroleum Product Barrels Exported to Mexico

Commodity	2012 (bbls)
Petroleum Products	3,448,215

Source: U.S.A. Trade Online

The actual volume of petroleum products as depicted in Table A.4, crossed into Mexico (primarily LPG) was 3,448,215 bbls in 2012 per U.S.A. Trade Online data from the U.S. Census Bureau, Foreign Trade Division. For that same year, the volume by value split by crossing and mode was provided by the BTS Transborder freight for 2012, which is shown in Table A.5 below.

Table A.5: 2012 Mineral Fuels Trade Value Exported to Mexico

Value (in Actual U.S. Dollars)				
Trade Type and Mode	Port/District Description	Commodity	2012	% Share
Exports Value by Truck	Tecate - California	Mineral fuels	\$320,365	0.11%
Exports Value by Truck	Otay Mesa Station - California	Mineral fuels	\$101,282,900	33.90%
Exports Value by Truck	Calexico-East - California	Mineral fuels	\$43,154,596	14.44%
Exports Value by Rail	San Ysidro - California	Mineral fuels	\$86,195,629	28.85%
Exports Value by Rail	Calexico-East - California	Mineral fuels	\$67,808,672	22.70%
			\$298,764,174	100.00%

Source: BTS Transborder Freight

From this table, the modal split for San Ysidro rail can be calculated as about 28.5 percent. Using this share multiplied by 3,448,215 bbls, it is 980,000 bbls. With each LPG tank car holding 770 bbls (average capacity per tank car per San Diego Freight Rail Consulting), the total crossing at San Ysidro is estimated to be only 1,275 rail cars. This matches the BTS source information.

These calculations demonstrate that the FAF version 4 data in 2012 are inaccurate. Therefore, FAF version 4 for crossborder should only be used to develop the forecast period CAGRs.

2. Crossborder Truck-Rail (Otay Mesa)

There is a substantial amount of Toyota vehicles that depart by rail from San Diego, but arrive initially into San Diego through the Otay Mesa border crossing via truck. FAF version 4 reflects this as a truck move in its entirety. However, in reality, about half of the imported vehicle volume from Mexico is loaded onto rail cars and leaves San Diego by rail. The remainder of the vehicles is transferred to other trucks.

Table A.6: 2012 Motorized Vehicles Imported from Mexico, Destined throughout the United States, by Tonnage

FR_INMODE	DMS_ORIG	SCTG2	DMS_MODE	KTons in 2012
Truck	San Diego, CA MSA	Motorized vehicles	Truck	364.8336

Source: FAF version 4

Rail cars of vehicles are unique in that their weight in the rail car is much lower than the average rail car loaded with other commodities. Loaded specialized rail cars for vehicles called auto racks average about 20 tons per load according to San Diego Freight Rail Consulting. This happens to be the same as the average weight on a truck loaded with vehicles.

The 365,000 tons is equivalent to 17,180 rail car/truck loads. This is higher than the actual volume, indicating that there is underrepresentation in the total tonnage by water. However, the key concern is that FAF version 4 does not provide an appropriate mode assignment to rail of these motorized vehicle shipments. The U.S. Census Bureau's U.S.A. Trade Online data table for inbound trucks from Mexico in 2012 is listed in Table A.7 below.

Table A.7: 2012 Motorized Vehicles Imported from Mexico, Destined to San Diego, by Value/Quantity/Unit Price

District	Country	Commodity	Measures	2012
San Diego, CA	Mexico	8704310020 Motor Vehicle For Transportation Of Goods, gross vehicle weight; 2.5 Metric Tons	Value (Dollars)	\$1,329,692,934
			Quantity	55,687
			Unit Price	\$23,877.98

Source: U.S.A. Trade Online

Table A.8 illustrates all vehicle imports into San Diego.

Table A.8: 2012 and 2015 Motorized Vehicles Imported to San Diego, Destined throughout the United States, by Transportation Mode and Tons

FR_INMODE	DMS_ORIG	SCTG2	DMS_MODE	KTons in 2012
Truck	San Diego, CA MSA	Motorized vehicles	Truck	364.8336
Water	San Diego, CA MSA	Motorized vehicles	Truck	295.0324
Water	San Diego, CA MSA	Motorized vehicles	Rail	1.6946
Water	San Diego, CA MSA	Motorized vehicles	Water	1.8291
Water	San Diego, CA MSA	Motorized vehicles	Multiple modes & mail	22.899
Air (include truck-air)	San Diego, CA MSA	Motorized vehicles	Truck	0.0043
Air (include truck-air)	San Diego, CA MSA	Motorized vehicles	Air (include truck-air)	0.0124
Multiple modes & Mail	San Diego, CA MSA	Motorized vehicles	Multiple modes & mail	0.5281

Source: FAF version 4

3. Import Water-Rail (Seaport)

A substantial volume of vehicles arrive by vessel at the Port of San Diego’s National City Marine Terminal (NCMT). According to the Unified Port of San Diego, about half of this volume moves out by rail with the remainder moving out by truck. However, the FAF data set from Table A.8 shows almost the entire volume departing by truck in 2012 and 2015.

FAF version 4 shows a total volume of nearly 325,000 tons of vehicles arriving in San Diego by water. Using the 20 tons per carload/truckload assumption means these imports generate approximately 16,000 truckloads/rail carloads. Although this calculation is lower than the actual, it is a close enough estimate to use in further analysis.

The issue is again the mode assignment for the further shipment domestically inland of motorized vehicles. Determining total rail carloadings for automotive vehicles can be elaborated on in more detail as with the crossborder truck example. Using the U.S. Census U.S. Trade Online data, total automotive vehicles imported into the NCMT during 2012 was 169,649. Determining how many rail carloads were required to handle these vehicle imports depends upon motor vehicle type and rail car type used. Table A.9 below shows vehicles per carload.

Table A.9: Rail Car Types and Motor Vehicle Capacity

Rail Car Type	Vehicles
Tri-level	15
Bi-level	10
Bi-level (Toyota truck)	8

Source: San Diego Rail Consulting

The NCMT has an even split between tri-level and bi-level rail cars. Therefore, the average NCMT carloading would be 12.5 vehicles. For Toyota trucks, it would be eight vehicles. Using the estimate of 50 percent volume to rail would give the following volumes as illustrated in Table A.10.

Table A.10: Assumed Rail Car Volumes from Vehicle Imports, Units, and Rail Carloads

2012	Total Volume (Units)	Rail Volume (Units)	Rail Carloads
Toyota	55,687	27,843	3,480
NCMT	169,649	84,824	6,786

Source: San Diego Rail Consulting

4. Domestic Rail

The remainder of the rail volume is domestic rail, which originates or terminates in San Diego, without being transferred via the Port of San Diego or across the Mexico border. With the exception of a small amount of scrap and perishable fruit carloads, the San Diego rail market is a terminating market with the rail freight flowing into San Diego from elsewhere in the United States. The table for domestic inbound rail is shown in Table A.11.

Table A.11: 2012 Domestic Inbound Rail Freight, by Commodity, Tons, and Value

DMS_DEST	SCTG2	MODE	KTons in 2012	M\$ in 2012
San Diego, CA	Other foodstuffs	Rail	5.1945	0.9754
San Diego, CA	Gasoline	Rail	85.1348	52.0331
San Diego, CA	Coal-n.e.c.	Rail	0.2011	0.0009
San Diego, CA	Basic chemicals	Rail	79.335	4.418
San Diego, CA	Plastics/rubber	Rail	1.7712	1.4682
San Diego, CA	Wood prods.	Rail	41.778	10.189
San Diego, CA	Textiles/leather	Rail	0.0348	0.0099
San Diego, CA	Machinery	Rail	3.4689	28.816
San Diego, CA	Motorized vehicles	Rail	37.395	275

Source: FAF version 4

The SCTG commodity classification for gasoline includes ethanol, which is the commodity inbound to San Diego under this category. The total volume equates to 3,180 carloads. This is slightly low, but sufficient for this analysis. The outbound rail freight flow data is shown below in Table A.12.

Table A.12: 2012 Domestic Outbound Rail Freight, by Commodity, Tons, and Value

DMS_ORIG	SCTG2	DMS_MODE	Total KTons in 2012	Total M\$ in 2012
San Diego, CA MSA	Motorized vehicles	Rail	104.76	\$1,301

Source: FAF version 4

Motor vehicles are a transfer to rail and truck as mentioned in the above sections. It is best to zero out the outbound domestic rail due to these data inaccuracies.

Summary of San Diego Rail Volume

Table A.10 and A.11 contain rail volumes which originate and terminate within San Diego County. Total rail volumes include the crossborder rail export (arriving inbound to San Diego by rail from elsewhere in the United States), crossborder vehicles by truck (shipped outbound by rail from San Diego), motor vehicles handled through the port of San Diego (shipped outbound by rail from San Diego), and domestic rail inbound and outbound. Table A.13 provides total rail volumes below.

Table A.13: 2012 San Diego Rail Flow Summary, by Direction

2012 Rail Flow	Inbound Rail	Outbound Rail
Crossborder Rail (San Ysidro)	3,552	0
Crossborder Truck (Toyota)	0	3,480
Port Inbound (Vehicles Handled by Pasha)	0	6,876
Domestic Inbound Rail	5,217	0
Domestic Outbound Rail	0	0
Totals	8,679	10,356

Source: San Diego Rail Consulting

Updated Seaport Base Year Data

For the Unified Port of San Diego, maritime cargo base year data was sourced from the U.S. Army Corps of Engineers (U.S. ACE) Waterborne Commerce Statistics. While not differentiating in the public data between the Tenth Avenue Marine Terminal and NCMT, this tonnage data captures international and domestic marine freight with detail unavailable in FAF.

Due to the relatively small freight tonnage (when compared to the truck mode) for the Port of San Diego, the FAF version 4 data was compared to and correlated with the more accurate U.S. ACE Waterborne Statistics for the year 2012. This data was in tons without any value assigned. Value was estimated by using the equivalent average dollar value per ton for the same commodity derived from FAF version 4 data for the Port of San Diego. The detailed procedure for arriving at seaport freight data is described below.

Data outputs for the tables are in **Bold**.

- 1) Obtain U.S. ACE Waterborne Commerce Statistics data for 2012 (tons)
- 2) Obtain FAF version 4 waterborne import and export data, 2012-2045 (tons and value)
- 3) Obtain FAF version 4 waterborne domestic data, inbound/outbound, 2012-2045 (tons, value)
- 4) Add inbound total tons to import total tons by year in MS Excel
- 5) Determine CAGR for total inbounds for 2015-2035 and 2035-2045 **Inbound CAGRs**
- 6) Add outbound total tons to export total tons by year in MS Excel
- 7) Determine CAGR for total outbounds for 2015-2035 and 2035-2045 **Outbound CAGRs**
- 8) Determine total inbound tons for Port in 2012 using U.S. ACE data **2012 Inbound Tons**
- 9) Determine total outbound tons for Port in 2012 using U.S. ACE data **2012 Outbound Tons**

- 10) Determine 2012 inbound value by multiplying FAF version 4 2012 total inbound value by the ratio of U.S. ACE total inbound tons by FAF version 4 total inbound tons **2012 Inbound Value**
- 11) Determine 2012 outbound value by multiplying FAF version 4 2012 total outbound value by the ratio of U.S. ACE total outbound tons by FAF version 4 total outbound tons **2012 Outbound Value**
- 12) Determine 2035 tons by using 2015-2035 CAGR, multiplied by 2012 tons **2035 Tons**
- 13) Determine 2050 tons by using 2035-2045 CAGR multiplied by 2035 tons **2050 Tons**
- 14) Determine 2035 value by using 2015-2035 CAGR, multiplied by 2012 value **2035 Value**
- 15) Determine 2050 value by using 2035-2045 CAGR multiplied by 2035 tons **2050 Value**
- 16) Determine value per ton in each cell by dividing value by tons for each year **Average Value**

Updated Airport Base Year Data

For the San Diego International Airport, air cargo handling data detail from the airport authority unavailable in the FAF version 4 was used as a supplement to the FAF data. This is because the relatively small volumes (when compared to the truck mode) associated with the San Diego air freight market in the FAF version 4 are not as accurate as the airport authority statistics. Air cargo value was estimated using FAF version 4 value per ton for San Diego air freight and compound annual growth rates (CAGRs).

Updated Pipeline Base Year Data

For the base year, the second-highest volume tonnage of any transport mode (after truck) in San Diego is pipeline. Because this mode was not analyzed in the original Comprehensive Freight Gateway Study, it has been added newly in this update. The San Diego pipeline tonnage volume data for gasoline, diesel, and natural gas have been derived from industry sources.

San Diego County petroleum products are fed into the county by the Santa Fe Pacific Pipeline (owned by Kinder Morgan, Inc.) which receives products from refineries in the Los Angeles basin. Those petroleum products include gasoline, diesel, and jet fuel.

Pipeline volumes were estimated in this study. Starting with an annual report for the Kinder Morgan Santa Fe Pacific Pipeline for the year 1995, the report indicated that the San Diego Line moved 31.9 million barrels of product. The FAF version 4 data provides a volume via pipeline into San Diego for the year 2012 of 4.5 million tons.

The procedure used to estimate the baseline pipeline volume is as follows:

- Convert gasoline barrels to tons using gasoline weight-to-volume of six pounds (lbs) per gallon (gal); $6 \text{ lbs/gal} \times 42 \text{ gal/bbl} \times 1 \text{ ton}/2,000 \text{ lbs}$ is equal to 0.126 tons per bbl.

The reported pipeline volume for 1995 was 31.9 million bbls.

- $31.9 \text{ million bbls} \times 0.126$ is equal to 4.02 million tons.

This is very close to the FAF version 3.5 2012 value. Assuming the pipeline operates at about the same annual average capacity utilization, the FAF version 4 data for pipelines was deemed accurate enough for this study.

Sources and References

California Department of Finance, "Occupational Employment Statistics, Labor Market Information, 2014, www.labormarketinfo.edd.ca.gov/data/occupations-data.html#Data

California Department of Transportation, CALTRANS District 11, "California-Baja California Border Master Plan Update," San Diego, CA, July 2014

California Department of Transportation, CALTRANS, Truck Traffic Volumes, Annual Average Daily Traffic, Truck AADT, 2010-2013, www.dot.ca.gov/hq/traffops/saferesr/trafdata/index.htm

Imperial Valley Association of Governments, "San Diego-Imperial Valley I-8 Corridor Study," El Centro, CA, February 2009

Imperial County Transportation Commission, "Imperial County 2013 Transportation Plan," El Centro, CA, November, 2013

Kinder Morgan, Petroleum Product Pipelines and Terminals Information, 2014, www.kindermorgan.com/business/products_pipelines/sfpp.aspx

Mexican Secretariat of Economic Development, "Infrastructure Statistics of Baja California," Mexicali, Baja California, 2014, www.investinbaja.gob.mx/

Mexican Secretariat of Economic Development, "Key Economic Indicators of Baja California," Mexicali, Baja California, 2014, www.investinbaja.gob.mx/en/profile/statistics#economical-characteristics

Mexican Secretariat of Economic Development, "Population Statistics of Baja California," Mexicali, Baja California, 2014, www.investinbaja.gob.mx/en/profile/statistics#population

San Diego Association of Governments, "Activity Centers in the San Diego Region," San Diego, CA, August 2007

San Diego Association of Governments, "Building a Foundation to Include Competitiveness: San Diego Regional Economic Prosperity Strategy," San Diego, CA, March 2008

San Diego Association of Governments, "Comprehensive Freight Gateway Study" Final Report, December 2009.

San Diego Association of Governments, Fact Sheets on: Bi-national Coordination (March 2006); Otay Mesa-Mesa de Otay Bi-national Corridor Strategic Plan (November 2007); and U.S.-Mexico Border (March 2006)

San Diego Association of Governments, "Indicators of Sustainable Competitiveness: A Quality of Life Index for San Diego" San Diego, CA, June 2005

San Diego Association of Governments, "Building a Foundation to Achieve Global Competitiveness: San Diego Regional Economic Prosperity Strategy," San Diego, CA, March 2008

San Diego Association of Governments, "Survey Analysis of Trade and Goods Movement between California and Baja California, Mexico," September 2003

San Diego Association of Governments, "Traded Clusters in the San Diego Region" San Diego, CA, September 2006

San Diego County Regional Airport Authority, "Air Traffic Statistics," San Diego, CA 2010-2014
www.san.org/sdia/at_the_airport/education/airport_statistics.aspx

U.S. Department of Agriculture, "Gross Values by Commodity Groups: USDA NASS California County Agricultural Commissioners' Report," 2011, 2012, 2013,
www.nass.usda.gov/Statistics_by_State/California/Publications/AgComm/Detail/index.asp

U.S. Department of Commerce, Bureau of Economic Analysis, "National Income and Product Accounts Table, Contributions to Percent Change in Real Gross Domestic Product," 2014,
www.bea.gov/iTable/iTable.cfm?ReqID=9&step=1#reqid=9&step=3&isuri=1&903=2

U.S. Department of Commerce, Economics and Statistics Administration, Bureau of the Census; County Population Estimates, Estimates of the Components of Resident Population Change for Counties: April 1, 2010 to July 1, 2012, Washington, D.C. 2013,
www.census.gov/popest/data/counties/totals/2012/CO-EST2012-01.html

U.S. Department of Commerce, Economics and Statistics Administration, Bureau of the Census; U.S. Department of Transportation, Bureau of Transportation Statistics, "2012 Commodity Flow Survey," Washington D.C., December 2014

U.S. Department of Commerce, Economics and Statistics Administration, Bureau of the Census, "U.S. International Services: Cross-Border Trade 2012, and Services Supplied Through Affiliates, 1987-2012," Washington D.C., October 2013

U.S. Department of Commerce, Economics and Statistics Administration, Bureau of the Census, "Annual Survey of Manufacturers," Washington D.C., September 2013,
www.census.gov/econ/manufacturing.html

U.S. Department of Commerce, Economics and Statistics Administration, Bureau of the Census, "Economic Census, 2007," Washington D.C., 2010, www.census.gov/econ/census/data

U.S. Department of Commerce, Economics and Statistics Administration, Bureau of the Census, Foreign Trade Division, "U.S.A. Trade® Online," Washington D.C., 2012-2015 U.S.A.trade.census.gov

U.S. Department of Defense, U.S. Army Corps of Engineers, Navigation Data Center, Waterborne Commerce Statistics Center, "Waterborne Commerce of the United States," New Orleans, LA, November, 2014, www.navigationdatacenter.us/data/datawucus.htm

U.S. Department of Homeland Security, Customs and Border Protection, Operations Management Report (OMR) database, Border Crossing/Entry Database, 2010-2014, available from the U.S. Department of Transportation, Bureau of Transportation Statistics,
transborder.bts.gov/programs/international/transborder/TBDR_BC/TBDR_BC_Index.html

U.S. Department of Labor, Bureau of Labor Statistics, "Detailed Industry Employment Ranked by Change," 2014, www.bls.gov/web/empsit/tab2.txt

U.S. Department of Transportation, Bureau of Transportation Statistics (BTS), North American Transborder Freight Data, www.bts.gov/programs/international/transborder/TBDR_QA.html

U.S. Department of Transportation, Federal Highway Administration, "Freight Analysis Framework (FAF³)," Washington D.C. 2014, ops.fhwa.dot.gov/Freight/freight_analysis/faf/index.htm

U.S. Department of Transportation, Federal Highway Administration, "Freight Transportation Improvements and the Economy," Washington D.C. June 2004

U.S. Department of Transportation, Federal Motor Carrier Safety Administration, "United States-Mexico Cross-Border Long-Haul Trucking Pilot Program Report to Congress," Washington, D.C. January 2015

U.S. Department of Transportation, Surface Transportation Board, "Carload Rail Waybill Sample," Washington D.C. 2012, www.stb.dot.gov/stb/industry/econ_waybill.html

APPENDIX B: FREIGHT GATEWAY STUDY UPDATE

FORECAST TABLES

The freight gateway forecast tables below reflect the study's combined methodologies articulating freight tons, value, and value per ton for all of the primary border region freight gateways.

San Diego County Border Truck & Rail Import Tonnage Forecast

Import Growth Scenario	Units	2012-2035		2050	2035-2050	
		2012	2035		CAGR	CAGR
Conservative	Thousand Tons	3,900	9,000	3.7%	13,900	3.0%
	Truckloads	195,000	451,000	3.7%	698,000	3.0%
	\$Millions	\$22,000	\$50,900	3.7%	\$70,000	2.1%
	\$ per Ton	\$5,700	\$5,600	0.0%	\$5,000	-0.8%
Mid	Thousand Tons	3,900	10,700	4.5%	19,900	4.2%
	Truckloads	195,000	537,000	4.5%	993,000	4.2%
	\$Millions	\$22,000	\$65,600	4.9%	\$122,700	4.3%
	\$ per Ton	\$5,700	\$6,100	0.3%	\$6,200	0.1%
Aggressive	Thousand Tons	3,900	12,200	5.1%	24,400	4.7%
	Truckloads	195,000	611,000	5.1%	1,220,000	4.7%
	\$Millions	\$22,000	\$76,600	5.6%	\$156,400	4.9%
	\$ per Ton	\$5,700	\$6,300	0.4%	\$6,400	0.2%

San Diego County Border Truck & Rail Export Tonnage Forecast

Export Growth Scenario	Units	2012-2035		2050	2035-2050	
		2012	2035		CAGR	CAGR
Conservative	Thousand Tons	3,400	6,200	2.6%	10,900	3.9%
	Truckloads	172,000	308,000	2.6%	546,000	3.9%
	\$Millions	\$12,500	\$24,900	3.0%	\$42,900	3.7%
	\$ per Ton	\$3,600	\$4,000	0.5%	\$3,900	-0.2%
Mid	Thousand Tons	3,400	7,000	3.1%	12,500	3.9%
	Truckloads	172,000	351,000	3.1%	626,000	3.9%
	\$Millions	\$12,500	\$29,800	3.9%	\$55,800	4.3%
	\$ per Ton	\$3,600	\$4,30	0.7%	\$4,500	0.3%
Aggressive	Thousand Tons	3,400	7,700	3.6%	15,300	4.7%
	Truckloads	172,000	387,000	3.6%	766,000	4.7%
	\$Millions	\$12,500	\$35,800	4.7%	\$80,800	5.6%
	\$ per Ton	\$3,600	\$4,600	1.1%	\$5,300	0.9%

- San Diego County Border tonnage forecast includes Otay Mesa and Tecate truck and San Ysidro rail information.
- FAF 4 data used to develop tonnage, value, value per ton, and compound annual growth rates (CAGRs).
- Truckloads are derived by using an average of 20 tons per 40 or 53-foot trailer. This calculation only captures hypothetical full 40 or 53-foot trailing truckloads, and does not include empties or small-duty trucks.
- The tonnage levels for exports reflect high U.S. content (40%) going into North American Free Trade Agreement (NAFTA) trade.
- The CAGR is different from the SANDAG Traffic and Revenue Study for Otay Mesa East due to the fact that it is based on tonnage; the Traffic and Revenue Study is based on truck traffic.
- Customs and Border Protection (CBP) statistics may vary slightly as they count trucks, empty containers, and loaded containers, not just tonnage.

Imperial County Border Truck & Rail Import Tonnage Forecast

Import Growth Scenario	Units			2012-2035		2035-2050	
		2012	2035	CAGR	2050	CAGR	
Conservative	Thousand Tons	1,900	4,100	3.4%	6,600	3.3%	
	Truckloads	94,000	203,000	3.4%	332,000	3.3%	
	\$Millions	\$6,700	\$16,300	3.9%	\$24,500	2.8%	
	\$ per Ton	\$3,600	\$4,000	0.5%	\$3,700	-0.6%	
Mid	Thousand Tons	1,900	4,700	4.0%	8,400	4.0%	
	Truckloads	94,000	233,000	4.0%	419,000	4.0%	
	\$Millions	\$6,700	\$20,400	4.9%	\$38,400	4.3%	
	\$ per Ton	\$3,600	\$4,400	0.9%	\$4,600	0.3%	
Aggressive	Thousand Tons	1,900	5,300	4.6%	10,000	4.4%	
	Truckloads	94,000	263,000	4.6%	503,000	4.4%	
	\$Millions	\$6,700	\$23,400	5.6%	\$47,800	4.9%	
	\$ per Ton	\$3,600	\$4,500	1.0%	\$4,800	0.4%	

Imperial County Border Truck & Rail Export Tonnage Forecast

Export Growth Scenario	Units	2012-2035		2012-2035 CAGR	2050	2035-2050 CAGR
		2012	2035			
Conservative	Thousand Tons	1,800	2,900	2.1%	5,000	3.7%
	Truckloads	90,000	143,000	2.1%	248,000	3.7%
	\$Millions	\$7,500	\$13,400	2.6%	\$22,600	3.5%
	\$ per Ton	\$4,200	\$4,700	0.5%	\$4,600	-0.2%
Mid	Thousand Tons	1,800	3,300	2.7%	6,000	4.0%
	Truckloads	90,000	166,000	2.7%	299,000	4.0%
	\$Millions	\$7,500	\$16,600	3.5%	\$31,500	4.4%
	\$ per Ton	\$4,200	\$5,000	0.8%	\$5,300	0.3%
Aggressive	Thousand Tons	1,800	3,800	3.3%	7,800	4.9%
	Truckloads	90,000	189,000	3.3%	389,000	4.9%
	\$Millions	\$7,500	\$20,700	4.5%	\$48,200	5.8%
	\$ per Ton	\$4,200	\$5,500	1.2%	\$6,200	0.8%

- San Diego County Border tonnage forecast includes Otay Mesa and Tecate truck and San Ysidro rail information.
- FAF 4 data used to develop tonnage, value, value per ton, and compound annual growth rates (CAGRs).
- Truckloads are derived by using an average of 20 tons per 40 or 53-foot trailer. This calculation only captures hypothetical full 40 or 53-foot trailing truckloads, and does not include empties or small-duty trucks.
- The tonnage levels for exports reflect high U.S. content (40%) going into North American Free Trade Agreement (NAFTA) trade.
- Customs and Border Protection (CBP) statistics may vary slightly as they count trucks, empty containers, and loaded containers, not just tonnage.

San Diego County Domestic Inbound Truck Tonnage Forecast

Inbound Growth Scenario	Units			2012-2035		2035-2050
		2012	2035	CAGR	2050	CAGR
Conservative	Thousand Tons	13,600	20,000	1.7%	23,400	1.0%
	Truckloads	682,000	1,000,000	1.7%	1,200,000	1.0%
	\$Millions	\$46,100	\$59,600	1.1%	\$74,000	1.5%
	\$ per Ton	\$3,400	\$3,000	-0.6%	\$3,200	0.4%
Mid	Thousand Tons	13,600	22,000	2.1%	26,200	1.2%
	Truckloads	682,000	1,100,000	2.1%	1,300,000	1.2%
	\$Millions	\$46,100	\$65,400	1.5%	\$82,800	1.6%
	\$ per Ton	\$3,400	\$3,000	-0.6%	\$3,200	0.4%
Aggressive	Thousand Tons	13,600	23,700	2.4%	28,900	1.3%
	Truckloads	682,000	1,200,000	2.4%	1,500,000	1.3%
	\$Millions	\$46,100	\$70,500	1.9%	\$91,400	1.7%
	\$ per Ton	\$3,400	\$3,000	-0.6%	\$3,200	0.4%

San Diego County Domestic Outbound Truck Tonnage Forecast

Outbound Growth Scenario	Units			2012-2035		2035-2050
		2012	2035	CAGR	2050	CAGR
Conservative	Thousand Tons	4,000	5,600	1.5%	7,100	1.6%
	Truckloads	201,000	280,000	1.5%	354,000	1.6%
	\$Millions	\$30,800	\$50,500	2.2%	\$65,700	1.8%
	\$ per Ton	\$7,700	\$9,000	0.7%	\$9,300	0.2%
Mid	Thousand Tons	4,000	6,100	1.9%	7,900	1.7%
	Truckloads	201,000	307,000	1.9%	396,000	1.7%
	\$Millions	\$30,800	\$55,400	2.6%	\$73,400	1.9%
	\$ per Ton	\$7,700	\$9,000	0.7%	\$9,300	0.2%
Aggressive	Thousand Tons	4,000	6,600	2.2%	8,700	1.9%
	Truckloads	201,000	331,000	2.2%	437,000	1.9%
	\$Millions	\$30,800	\$59,600	2.9%	\$80,800	2.0%
	\$ per Ton	\$7,700	\$9,000	0.7%	\$9,200	0.2%

- FAF 4 data used to develop tonnage, value, value per ton, and CAGRs.
- Truckloads are derived by using an average of 20 tons per 40 or 53-foot trailer. This calculation only captures hypothetical full 40 or 53-foot trailing truckloads, and does not include empties or small-duty trucks.
- The table illustrates domestically generated tonnage entering/leaving San Diego County. Table does not double count tonnage entering through land POEs or the seaport, nor does it count tonnage of internal circulation.

San Diego County Domestic Internal Truck Tonnage Forecast

Internal Growth Scenario	Units	2012-2035		2035-2050	2012-2035		2035-2050	
		2012	2035		CAGR	2050	CAGR	
Conservative	Thousand Tons	32,400	33,400	0.1%	36,300	0.5%		
	Truckloads	1,600,000	1,700,000	0.1%	1,800,000	0.5%		
	\$Millions	\$24,200	\$30,400	1.0%	\$35,200	1.0%		
	\$ per Ton	\$750	\$900	0.9%	\$1,000	0.4%		
Mid	Thousand Tons	32,400	36,700	0.5%	40,500	0.7%		
	Truckloads	1,600,000	1,800,000	0.5%	2,000,000	0.7%		
	\$Millions	\$24,200	\$33,400	1.4%	\$39,300	1.1%		
	\$ per Ton	\$750	\$900	0.9%	\$1,000	0.4%		
Aggressive	Thousand Tons	32,400	39,600	0.9%	44,800	0.8%		
	Truckloads	1,600,000	2,000,000	0.9%	2,200,000	0.8%		
	\$Millions	\$24,200	\$36,000	1.7%	\$43,500	1.3%		
	\$ per Ton	\$750	\$900	0.9%	\$1,000	0.4%		

- FAF 4 data used to develop tonnage, value, value per ton, and CAGRs.
- Truckloads are derived by using an average of 20 tons per 40 or 53-foot trailer. This calculation only captures hypothetical full 40 or 53-foot trailing truckloads, and does not include empties or small-duty trucks.
- The table illustrates domestically generated tonnage within San Diego County defined as internal circulation.
- Excludes any inbound to San Diego and outbound from San Diego domestic truck tonnage.

Port of San Diego Seaport Import Tonnage Forecast

Import Growth Scenario	Units	2012-2035		2050	2035-2050	
		2012	2035		CAGR	CAGR
Conservative	Thousand Tons	1,100	2,100	2.9%	3,400	3.2%
	Truckloads	55,000	106,000	2.9%	169,000	3.2%
	\$Millions	\$5,100	\$7,400	1.6%	\$7,200	-0.2%
	\$ per Ton	\$4,700	\$3,500	-1.2%	\$2,100	-3.3%
Mid	Thousand Tons	1,100	2,400	3.5%	4,300	3.9%
	Truckloads	55,000	122,000	3.5%	216,000	3.9%
	\$Millions	\$5,100	\$10,500	3.2%	\$16,000	2.9%
	\$ per Ton	\$4,700	\$4,300	-0.3%	\$3,700	-1.0%
Aggressive	Thousand Tons	1,100	2,800	4.1%	5,500	4.7%
	Truckloads	55,000	138,000	4.1%	275,000	4.7%
	\$Millions	\$5,100	\$13,300	4.2%	\$28,300	5.2%
	\$ per Ton	\$4,700	\$4,800	0.1%	\$5,100	0.4%

Port of San Diego Seaport Export Tonnage Forecast

Export Growth Scenario	Units	2012-2035		2050	2035-2050	
		2012	2035		CAGR	CAGR
Conservative	Thousand Tons	30	135	6.9%	250	4.3%
	Truckloads	1,400	6,700	6.9%	12,500	4.3%
	\$Millions	\$150	\$400	4.5%	\$650	3.1%
	\$ per Ton	\$5,300	\$3,100	-2.3%	\$2,600	-1.1%
Mid	Thousand Tons	30	150	7.4%	275	4.2%
	Truckloads	1,400	7,400	7.4%	13,700	4.2%
	\$Millions	\$150	\$480	5.1%	\$820	3.6%
	\$ per Ton	\$5,300	\$3,300	-2.1%	\$3,000	-0.6%
Aggressive	Thousand Tons	30	155	7.6%	295	4.4%
	Truckloads	1,400	7,700	7.6%	14,700	4.4%
	\$Millions	\$150	\$550	5.8%	\$1,100	4.6%
	\$ per Ton	\$5,300	\$3,600	-1.7%	\$3,700	0.2%

Port of San Diego Seaport Domestic Inbound Tonnage Forecast

Inbound Growth Scenario	Units	2012-2035		2050	2035-2050	
		2012	2035		CAGR	CAGR
Conservative	Thousand Tons	150	210	1.5%	180	-1.0%
	Truckloads	7,300	10,300	1.5%	8,800	-1.0%
	\$Millions	\$705	\$780	0.4%	\$770	-1.0%
	\$ per Ton	\$4,800	\$3,800	-1.1%	\$4,400	0.9%
Mid	Thousand Tons	150	230	1.9%	200	-0.9%
	Truckloads	7,300	11,300	1.9%	9,900	-0.9%
	\$Millions	\$705	\$860	0.9%	\$860	0.0%
	\$ per Ton	\$4,800	\$3,800	-1.1%	\$4,400	0.9%
Aggressive	Thousand Tons	150	240	2.3%	220	-0.7%
	Truckloads	7,300	12,200	2.3%	10,900	-0.7%
	\$Millions	\$705	\$925	1.2%	\$950	0.2%
	\$ per Ton	\$4,800	\$3,800	-1.0%	\$4,400	0.9%

Port of San Diego Seaport Domestic Outbound Tonnage Forecast

Outbound Growth Scenario	Units	2012-2035		2050	2035-2050	
		2012	2035		CAGR	CAGR
Conservative	Thousand Tons	4	2	-1.8%	1	-7.4%
	Truckloads	180	120	-1.8%	4	-7.4%
	\$Millions	\$2	\$2	-1.8%	\$1	-7.4%
	\$ per Ton	\$670	\$670	0.0%	\$670	0.0%
Mid	Thousand Tons	4	3	-1.4%	1	-7.2%
	Truckloads	180	130	-1.4%	45	-7.2%
	\$Millions	\$2	\$2	3.0%	\$1	2.1%
	\$ per Ton	\$670	\$670	0.0%	\$670	0.0%
Aggressive	Thousand Tons	4	3	-1.1%	1	-7.1%
	Truckloads	180	140	-1.1%	50	-7.1%
	\$Millions	\$2	\$2	-1.1%	\$1	-7.1%
	\$ per Ton	\$670	\$670	0.0%	\$670	0.0%

- Tonnage 2012 base year was derived from the U.S. Army Corps Waterborne data.
- Value was calculated using both FAF 4 value and tonnage and U.S. Army Corps Waterborne tonnage data. Assumed CAGRs from FAF 4.
- Truckloads are derived by using an average of 20 tons per 40 or 53-foot trailer. This calculation only captures hypothetical full 40 or 53-foot trailing truckloads, and does not include empties or small-duty trucks.
- Tonnage is for both TAMT and NCMT combined.

- The Port will implement a TAMT Redevelopment Plan likely to project higher forecast information; this study will be based on significant modifications to the marine terminal to enable such growth.
- Similarly, the Port expects to launch an aggressive export promotion campaign, which would cause the export forecast numbers to rise.
- FAF 4 only predicts tonnage, for reference actual 2012 TEUs were 102,156 per the American Association of Port Authorities.
- Domestic inbound/outbound is defined as domestically produced and shipped to another domestic destination, aka Jones Act trade.

San Diego International Airport Import Cargo Tonnage Forecast

Import Growth Scenario	Units	2012-2035			2035-2050	
		2012	2035	CAGR	2050	CAGR
Conservative	Thousand Tons	2	9	7.6%	12	1.9%
	Truckloads	85	450	7.6%	595	1.9%
	\$Millions	\$230	\$800	5.7%	\$1,300	2.9%
	\$ per Ton	\$134,800	\$90,800	-1.7%	\$105,700	1.0%
Mid	Thousand Tons	2	12	8.8%	21	4.1%
	Truckloads	85	580	8.8%	1,100	4.1%
	\$Millions	\$230	\$1,000	6.8%	\$1,900	4.3%
	\$ per Ton	\$134,800	\$88,200	-1.8%	\$90,800	0.2%
Aggressive	Thousand Tons	2	14	9.7%	28	4.8%
	Truckloads	85	700	9.7%	1,400	4.8%
	\$Millions	\$230	\$1,200	7.5%	\$2,500	4.9%
	\$ per Ton	\$134,800	\$86,200	-1.9%	\$88,100	0.2%

San Diego International Airport Export Cargo Tonnage Forecast

Export Growth Scenario	Units	2012-2035			2035-2050	
		2012	2035	CAGR	2050	CAGR
Conservative	Thousand Tons	4	9	3.6%	17	4.1%
	Truckloads	210	470	3.6%	860	4.1%
	\$Millions	\$640	\$1,900	4.8%	\$3,400	4.1%
	\$ per Ton	\$150,900	\$198,700	1.2%	\$197,700	0.0%
Mid	Thousand Tons	4	11	4.3%	21	4.4%
	Truckloads	210	550	4.3%	1,100	4.4%
	\$Millions	\$640	\$2,300	5.7%	\$4,500	4.6%
	\$ per Ton	\$150,900	\$208,000	1.4%	\$213,000	0.2%
Aggressive	Thousand Tons	4	13	4.9%	28	5.4%
	Truckloads	210	640	4.9%	1,400	5.4%
	\$Millions	\$640	\$2,900	6.8%	\$7,000	6.1%
	\$ per Ton	\$150,900	\$227,300	1.8%	\$251,500	0.7%

San Diego International Airport Domestic Inbound Cargo Tonnage Forecast

Inbound Growth Scenario	Units	2012-2035		2012-2035 CAGR	2050	2035-2050 CAGR
		2012	2035			
Conservative	Thousand Tons	65	80	0.8%	95	1.4%
	Truckloads	3,200	3,900	0.8%	4,800	1.4%
	\$Millions	\$5,400	\$7,100	1.2%	\$9,100	1.7%
	\$ per Ton	\$83,200	\$90,900	0.4%	\$94,600	0.3%
Mid	Thousand Tons	65	85	1.2%	110	1.6%
	Truckloads	3,200	4,300	1.2%	5,400	1.6%
	\$Millions	\$5,400	\$7,800	1.6%	\$10,200	1.8%
	\$ per Ton	\$83,200	\$90,700	0.4%	\$94,300	0.3%
Aggressive	Thousand Tons	65	90	1.6%	120	1.7%
	Truckloads	3,200	4,600	1.6%	6,000	1.7%
	\$Millions	\$5,400	\$8,400	1.9%	\$11,200	2.0%
	\$ per Ton	\$83,200	\$90,600	0.4%	\$94,000	0.2%

San Diego International Airport Domestic Outbound Cargo Tonnage Forecast

Outbound Growth Scenario	Units	2012-2035		2012-2035 CAGR	2050	2035-2050 CAGR
		2012	2035			
Conservative	Thousand Tons	67	105	1.9%	130	1.6%
	Truckloads	3,400	5,100	1.9%	6,500	1.6%
	\$Millions	\$5,800	\$10,500	2.6%	\$14,000	2.0%
	\$ per Ton	\$87,000	\$101,700	0.7%	\$107,300	0.4%
Mid	Thousand Tons	67	110	2.3%	145	1.7%
	Truckloads	3,400	5,600	2.3%	7,300	1.7%
	\$Millions	\$5,800	\$11,500	3.0%	\$15,700	2.1%
	\$ per Ton	\$87,000	\$102,000	0.7%	\$107,600	0.4%
Aggressive	Thousand Tons	67	120	2.6%	160	1.9%
	Truckloads	3,400	6,100	2.6%	8,000	1.9%
	\$Millions	\$5,800	\$12,400	3.3%	\$17,300	2.3%
	\$ per Ton	\$87,000	\$102,200	0.7%	\$108,000	0.4%

- Tonnage derived from SDIA 2012 published air cargo information which was more precise than FAF 4.
- Value was derived from FAF 4; assumed CAGRs from FAF 4.
- Truckloads are derived by using an average of 20 tons per 40 or 53-foot trailer. This calculation only captures hypothetical full 40 or 53-foot trailing truckloads, and does not include empties or small-duty trucks.
- Does include belly-cargo in passenger service and passenger planes and all air cargo courier services, but does not include U.S. mail cargo.

San Diego Pipeline Inbound Cargo Tonnage Forecast

Inbound Growth Scenario	Units	2012-2035			2035-2050	
		2012	2035	CAGR	2050	CAGR
Conservative	Thousand Tons	4,000	1,700	-3.7%	670	-5.9%
	Million Bbls	31,900	13,300	-3.7%	5,300	-5.9%
	\$Millions	\$3,100	\$1,300	-3.7%	\$510	-5.9%
	\$ per Ton	\$765	\$765	0.0%	\$765	0.0%
Mid	Thousand Tons	4,000	1,800	-3.3%	750	-5.8%
	Million Bbls	31,900	14,600	-3.3%	6,000	-5.8%
	\$Millions	\$3,100	\$1,400	-3.3%	\$570	-5.8%
	\$ per Ton	\$765	\$765	0.0%	\$765	0.0%
Aggressive	Thousand Tons	4,000	2,000	-3.0%	825	-5.7%
	Million Bbls	31,900	15,700	-3.0%	6,600	-5.7%
	\$Millions	\$3,100	\$1,500	-3.0%	\$630	-5.7%
	\$ per Ton	\$765	\$765	0.0%	\$765	0.0%

- Tonnage and value derived from FAF 4 and validated by industry data;
- A Bbls represents one stock tank barrel of 42 gallons of liquid volume. Millions of Bbls was derived by converting tons/bbl where .126 tons is equivalent to one barrel.
- Assumed CAGRs from FAF 4.
- Primarily gasoline and diesel; natural gas is considered a utility; and is measured in millions of Bbls and tons.

APPENDIX C: FREIGHT GATEWAY STUDY UPDATE

REGIONAL VEHICLE IMPORT, EXPORT, PROCESSING, AND DISTRIBUTION

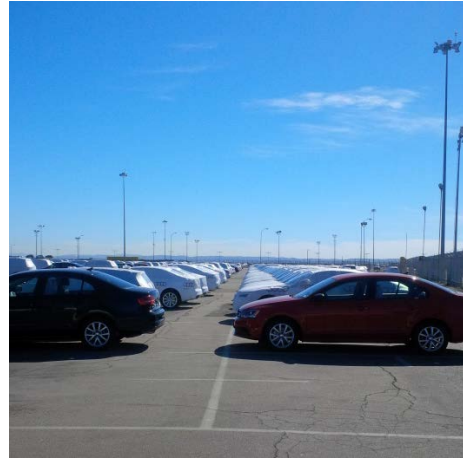

By:

SD Freight Rail Consulting

Introduction

San Diego is a major transportation, processing, storage, and distribution center for finished vehicles. In terms of US Customs District vehicle volumes, the San Diego Customs District ranks 8th in imports, 12th in exports, and 9th in total volume.

This “vignette” is a component of the SANDAG 2015 Freight Gateway Study Update. Its purpose is to highlight the characteristics of the San Diego vehicle logistics industry and its freight elements.

San Diego vehicle import trends are shown in the chart below:

Figure C.1: 2009-2014 San Diego Vehicle Imports by Seaport and Land Port

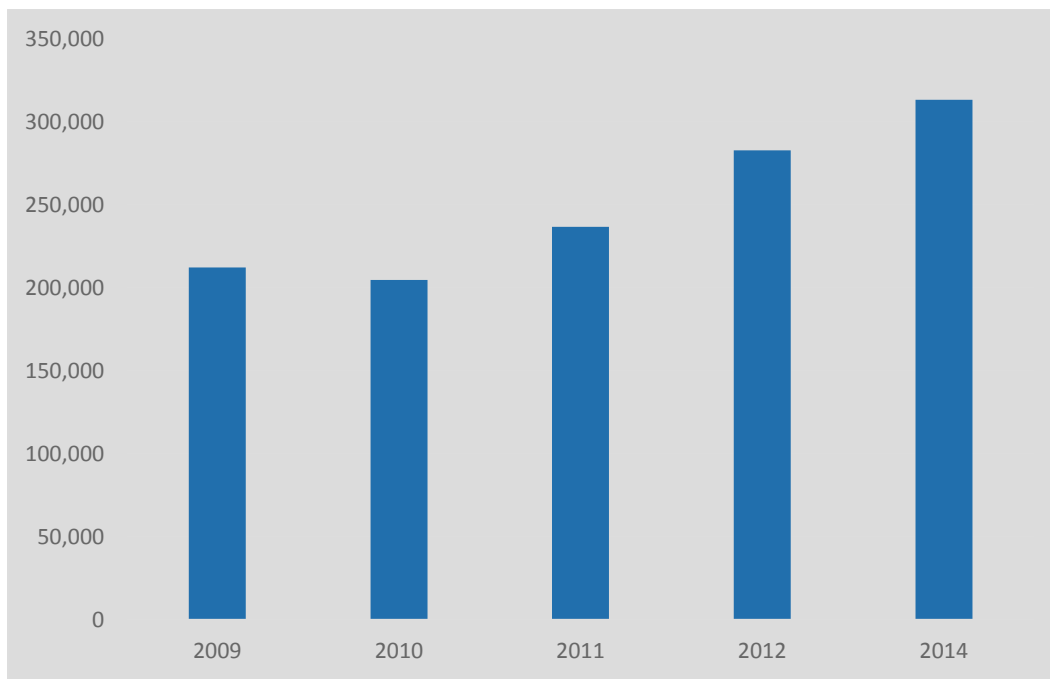

Source: U.S. Census

Vehicle operations include all major modes of transportation including vessel, rail, and truck. Key parts for vehicle processing are shipped via air freight. Major stakeholders include the Port of San Diego and Burlington Northern Santa Fe (BNSF) Railway.

This report is a description of this major freight activity. It is divided into three sections:

- Physical description of facilities
- Process description
- Data

Physical Description of Facilities

San Diego vehicle operations consist of two transportation, processing, and distribution facilities; the BNSF San Diego Auto Facility and the Pasha National City Marine Terminal (NCMT).

Figure C.2: San Diego Vehicle Operations Facilities



Source: SD Freight Rail Consulting

Table C.1: San Diego Vehicle Operations Facilities Information

Information Items	BNSF San Diego Auto Facility	Pasha NCMT
Acres	20	160
Vehicle Bays	1,025	22,000
Rail car spots	41	143
Berths	None	4
2013 Volume	60,000	361,372

Source: SD Freight Rail Consulting

Figure C.3: San Diego Area Vehicle Freight Flow

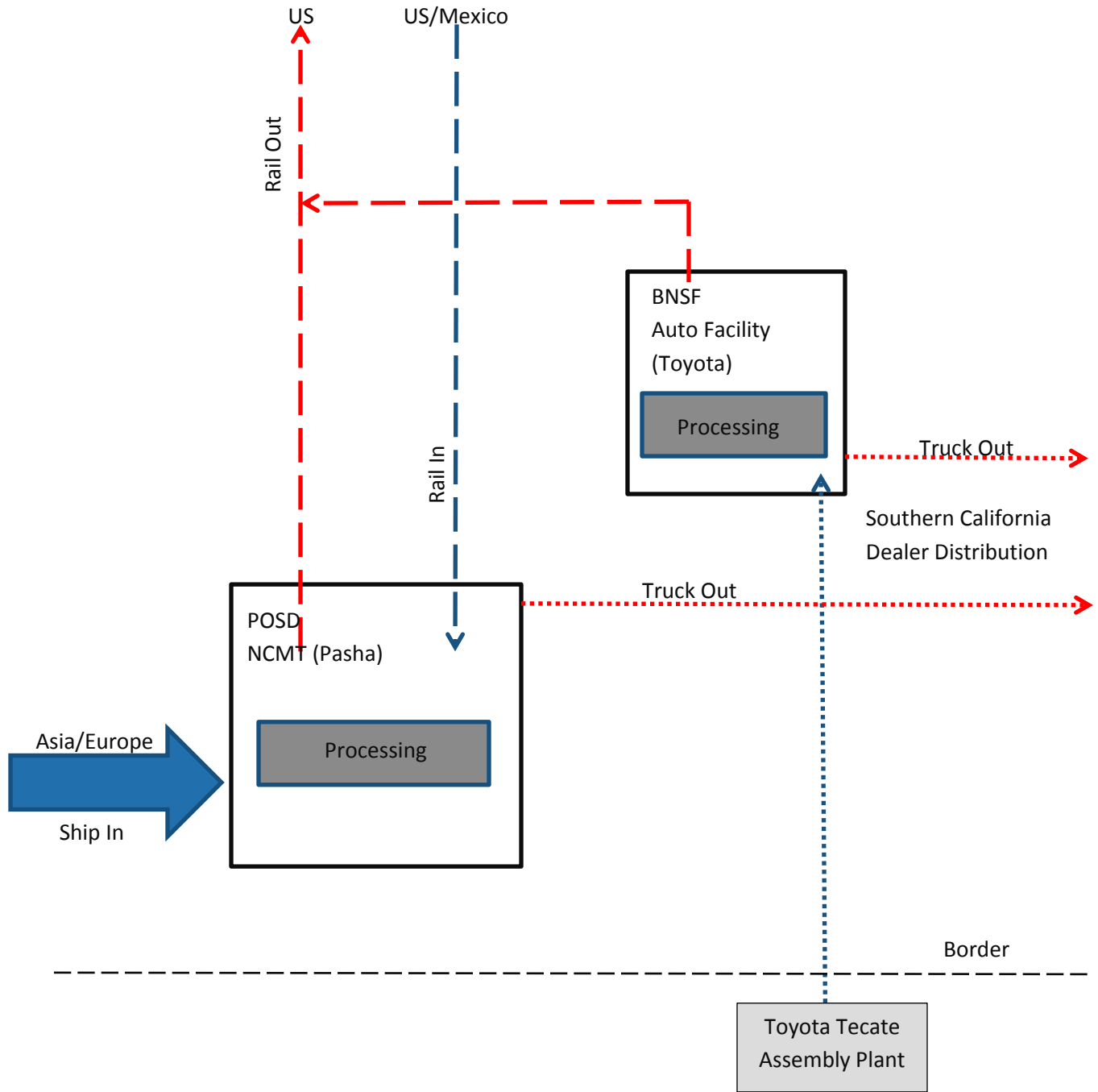

Source: SD Freight Rail Consulting

Figure C.4: BNSF San Diego Auto Facility



Source: SD Freight Rail Consulting

The BNSF facility is located south of downtown San Diego and is adjacent to the Tenth Avenue Marine Terminal (TAMT) and BNSF San Diego rail yard.

Presently the facility is used exclusively for processing and distributing Toyota Tacoma vehicles produced in Mexico and processed in San Diego. The vehicles are trucked from the plant at Tecate to the facility. After processing the trucks are shipped by rail to national rail heads or loaded on trucks for regional distribution to dealers.

Domestic outbound vehicle volumes are approximately 25% by truck and 75% by rail.

Services:

- Vehicle processing
- Rail car loading
- Rail car repair

Figure C.5: BNSF San Diego Auto Facility Process

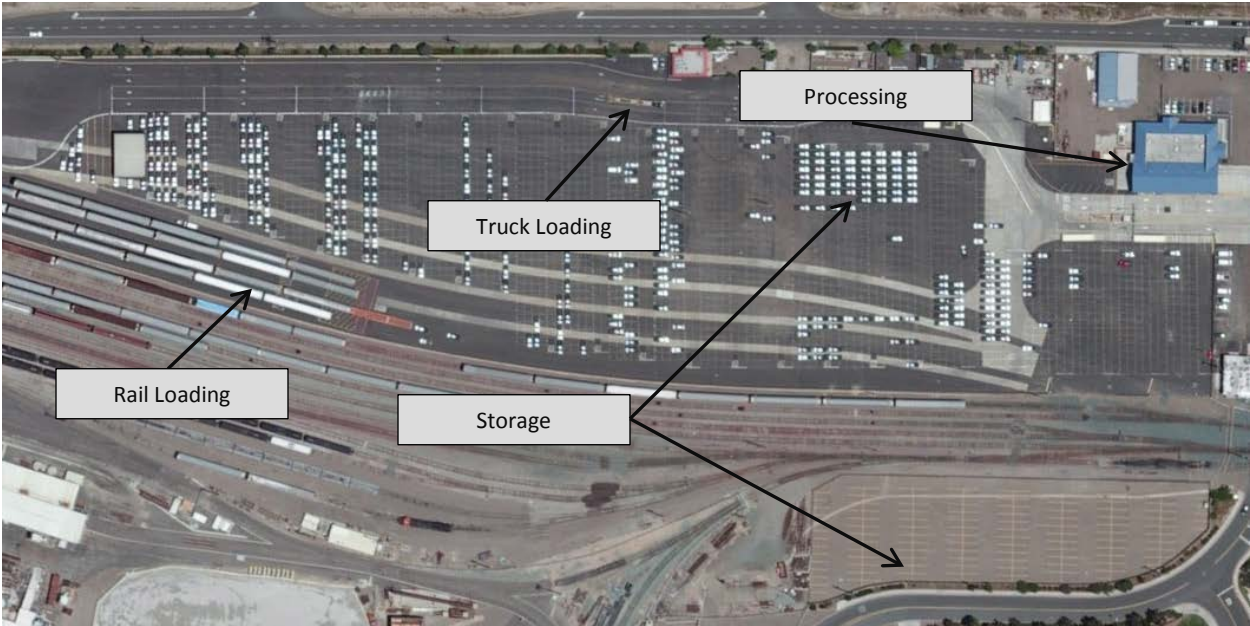

Source: SD Freight Rail Consulting

Figure C.6: San Diego BNSF Auto Facility Vehicle Flow

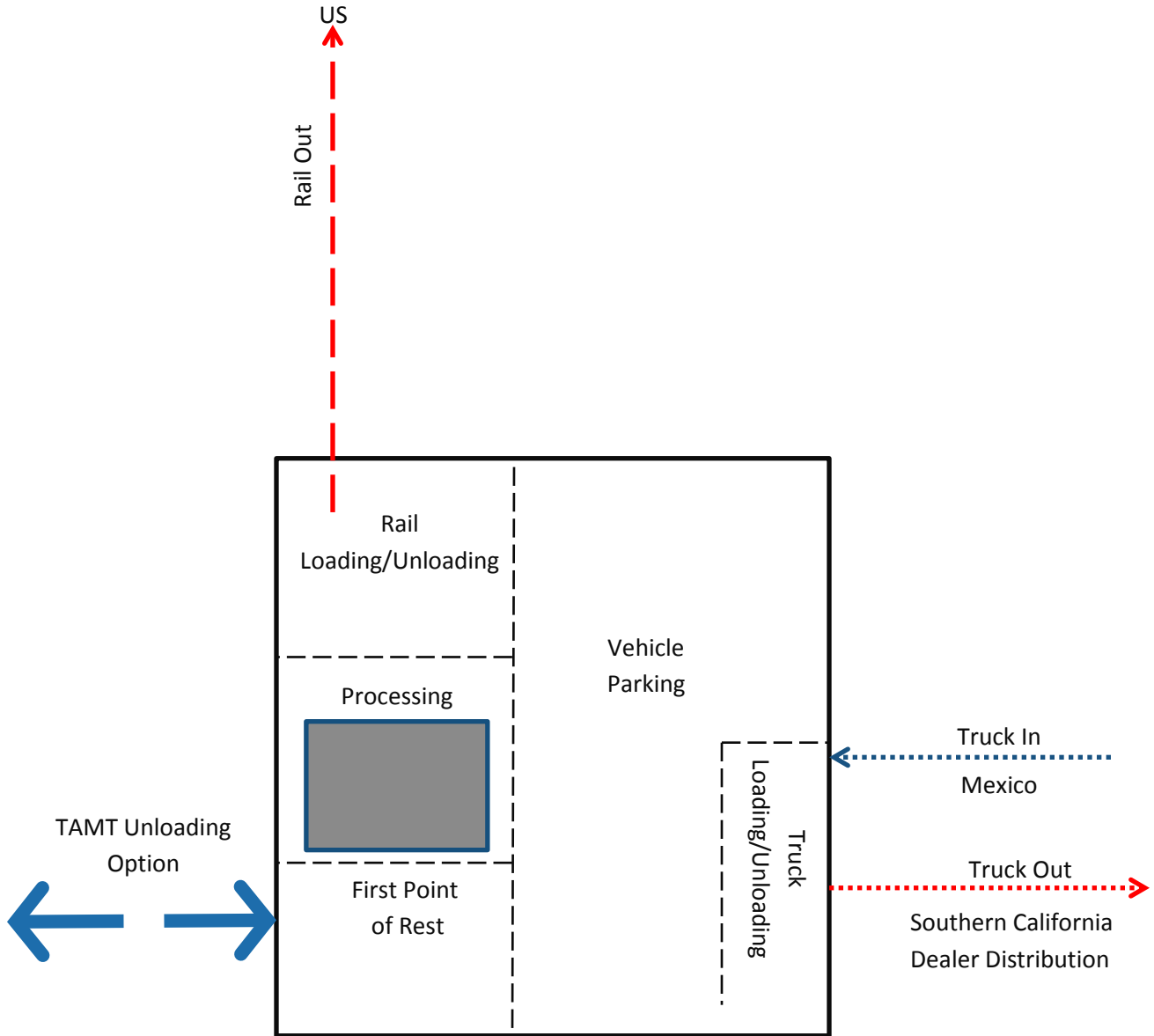

Source: SD Freight Rail Consulting

Figure C.7: Pasha NCMT



Source: SD Freight Rail Consulting

The Pasha NCMT facility is located on the Port of San Diego National City Marine Terminal. It also includes the BNSF Tidelands Auto Facility which is outside of Port tidelands.

The facility accommodates all modes, both inbound. It is one of the largest auto facilities on the US West Coast. Major customers include Mazda, Glovis (Hyundai/Kia), Volkswagen, Toyota, Fiat, Audi, and Porsche.

The multiple ship berths, major rail loading with loop track, and access to freeways make this a preferred location to serve the Southern California vehicle market.

Domestic outbound vehicle volumes are approximately 25 percent by truck and 75 percent by rail.

Services:

- Vehicle processing
- Ship loading and unloading
- Rail car loading and unloading
- Truck loading and unloading
- Rail car repair
- Rental car reconditioning

Figure C.8: Pasha NCMT Vehicle Process

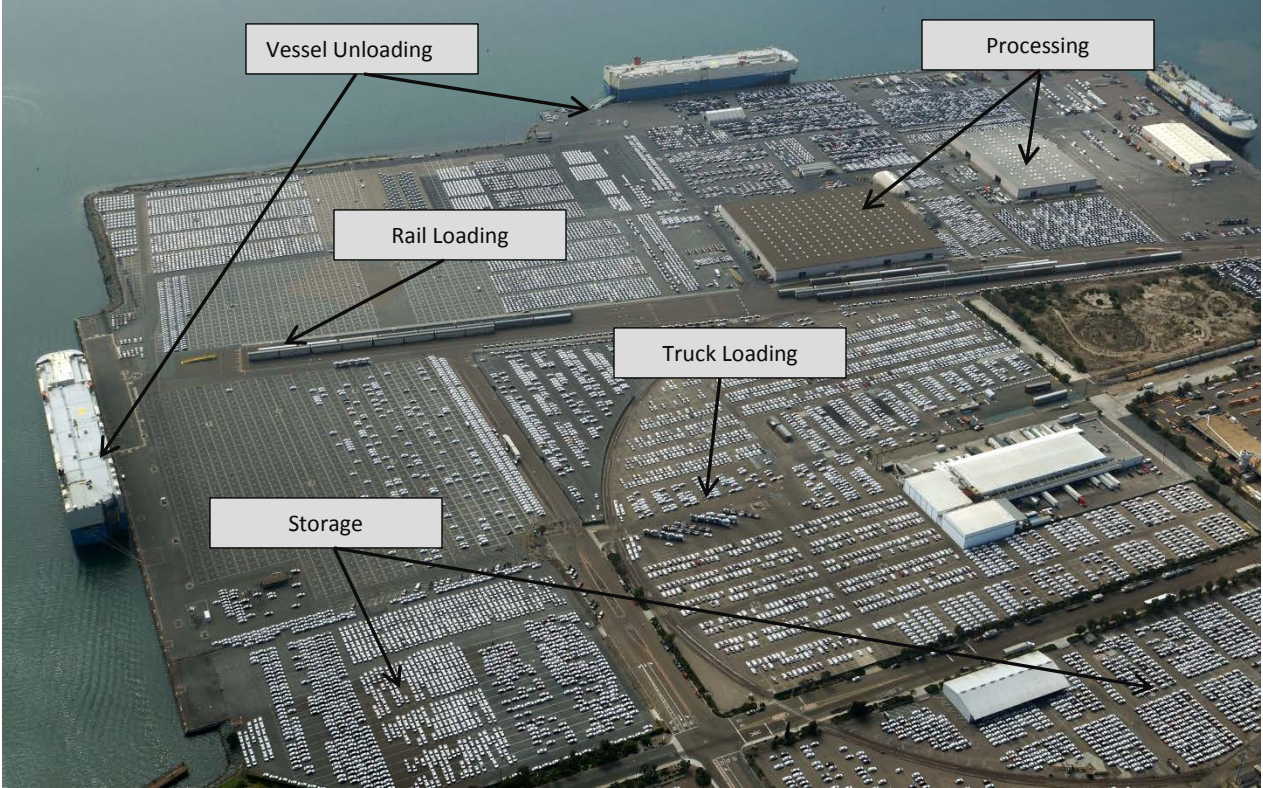

Source: SD Freight Rail Consulting

Figure C.9: Pasha National City Marine Terminal Vehicle Flow

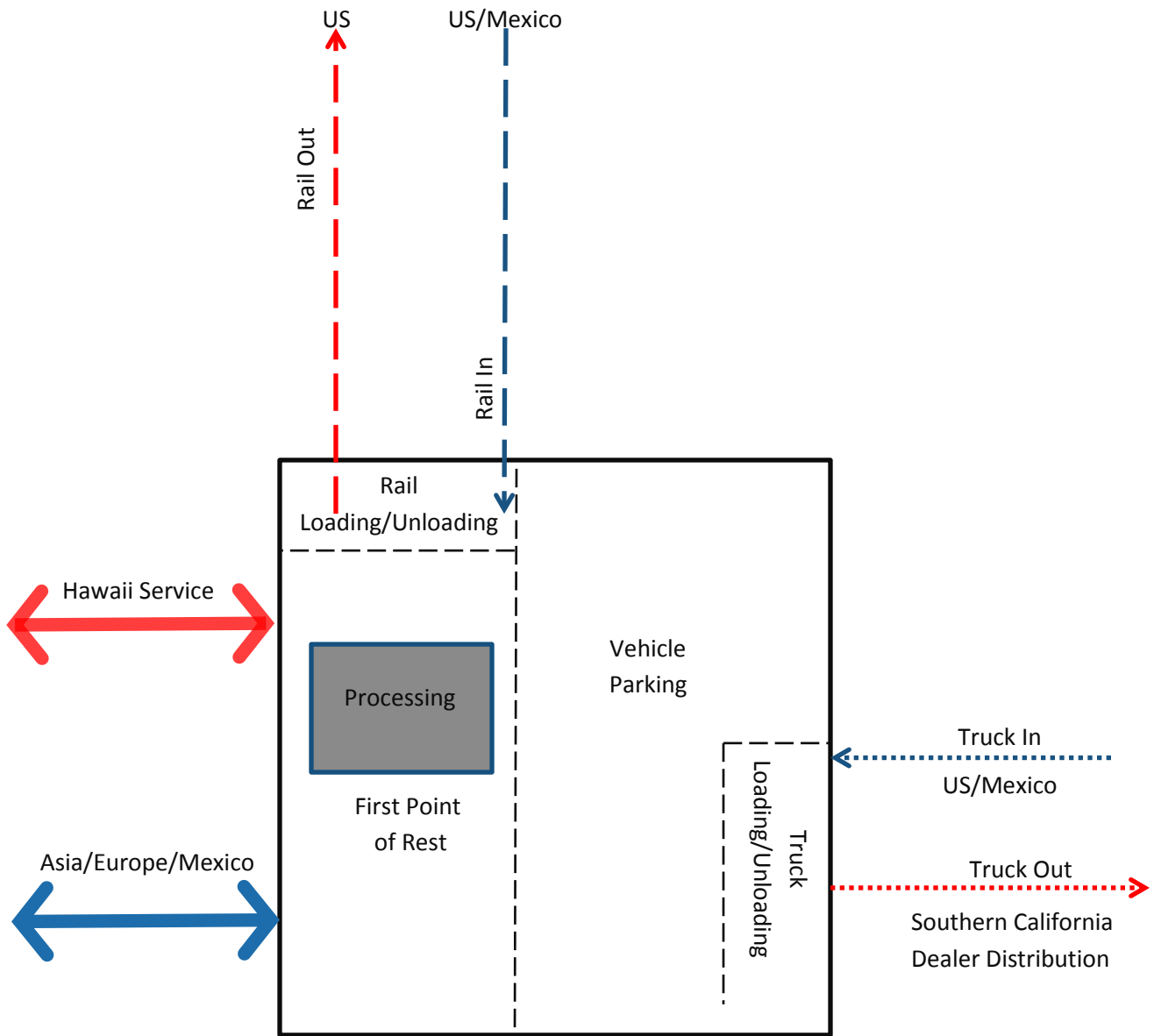

Source: SD Freight Rail Consulting

Rail Infrastructure

Both auto facilities use the same common rail facilities provided by BNSF.

Figure C.10: BNSF Rail Track Operations

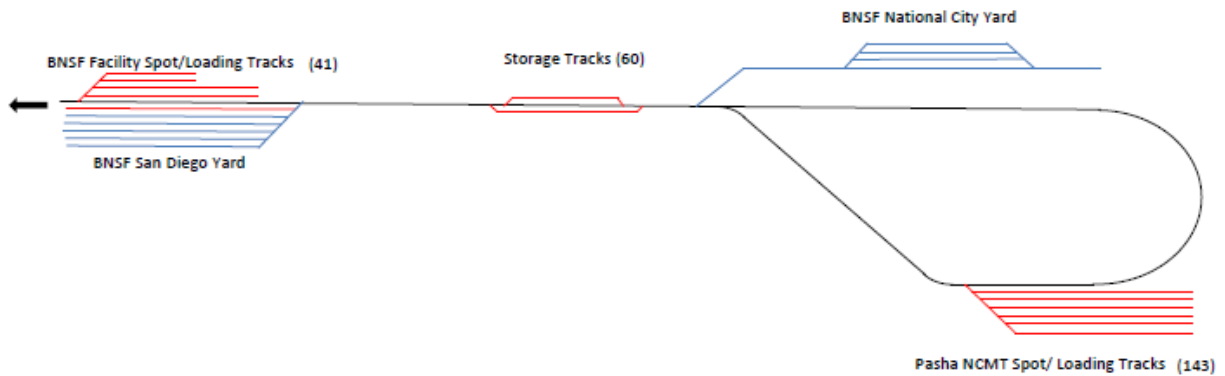

Source: SD Freight Rail Consulting

Both facilities utilize a daily outbound loaded train and inbound empty train.

Process Description

The vehicle logistics facility operations include the following processes; transportation, processing, storage, and distribution.

Inbound vehicle transportation includes vessel, rail, and truck. After the vehicles are unloaded, they are stored prior to final distribution, or sent to processing. After processing, vehicles are placed into storage for final distribution. Final distribution can be by vessel, rail, or truck.

Figure C.11: Vehicle Process Description

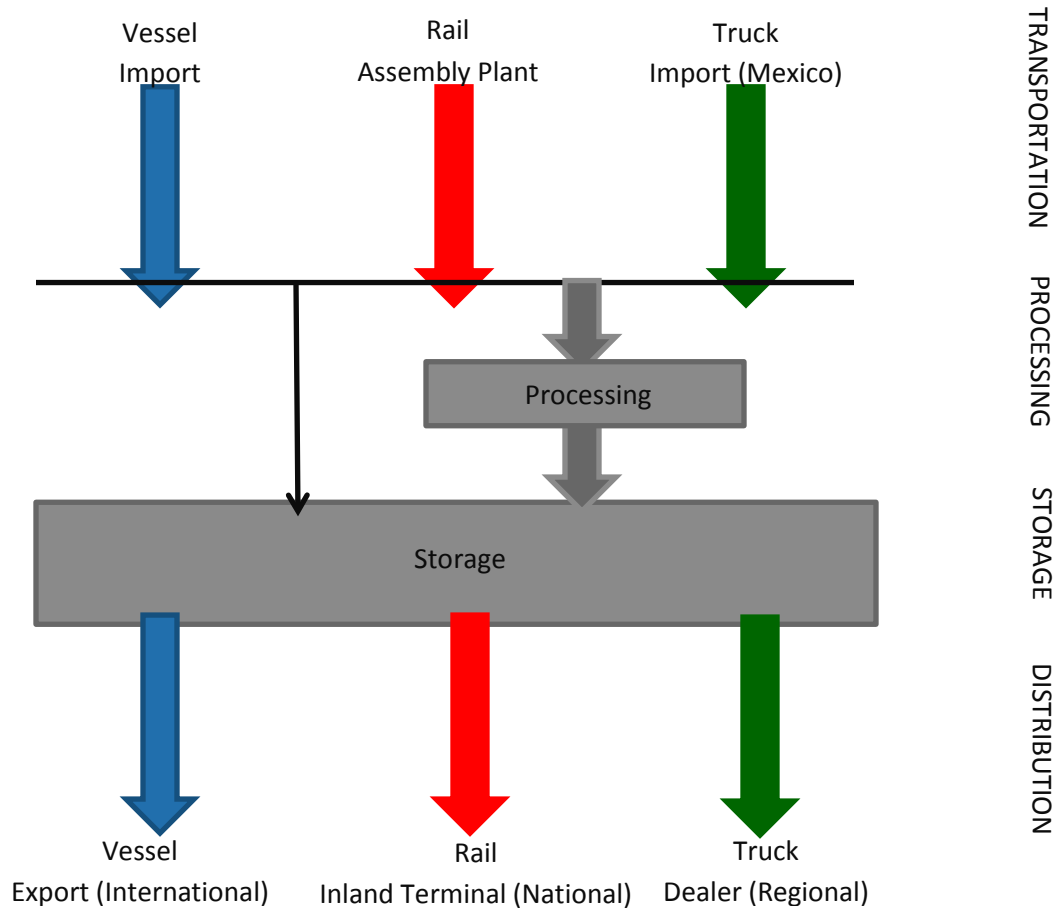

Source: SD Freight Rail Consulting

Figure C.12: Transportation & Distribution - Vessel



Vehicle driving of stern ramp



Deck storage inside ship



Pure Car/Truck Carrier (PCTC) Vessel



Vehicle unloading on ramp

Source: SD Freight Rail Consulting

Car carrier ship capacity is measured in CEUs (Car Equivalent Units). Most existing car carriers are over 3,000 CEU. Recent trends have been for shipping companies to use larger ships and make fewer calls with a greater number of vehicles loaded and carried per trip. The most recent expansion has been in the 5000+ CEU category with newer 6000+ CEU vessels being built to take advantage of economies of scale. There are 768 car carriers in the fleet and 569 have a capacity of 4,000 or more cars (74% of the fleet).

Vessels are typically loaded to near capacity and discharge cargo at 2-3 ports before returning to the port of origin.

Vehicles are unloaded and drive to the first point of rest prior to processing or storage. A vessel usually unloads within one shift. Discharge volumes can exceed 2,000 vehicles per vessel.

Figure C.13: Transportation & Distribution - Rail



Cars driving on rail car lower deck



Mobile "Buck Loader"



Trilevel autoracks

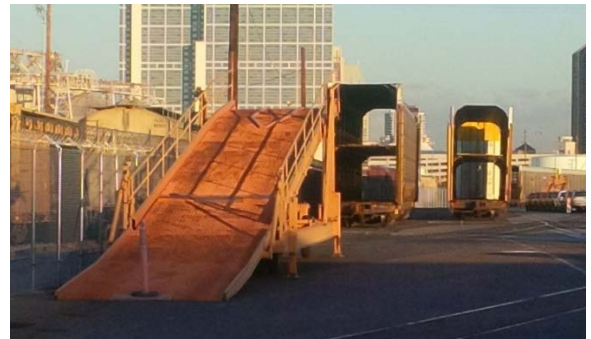

Bilevel autoracks

Source: SD Freight Rail Consulting

There are three major rail car configurations; bilevel (two decks), trilevel (three decks), and the articulated AutoMax (two or three decks).

Loading is accomplished using a "Buck Loader" which is a mobile ramp which elevates to the deck height of a rail car in order to drive vehicles off and on the rail car.

The capacities of the rail cars are dependent upon the size of the vehicle model carried. The ranges are below:

- Bilevel 8-10
- Trilevel 12-15
- Automax 19-22

Loaded trains leaving San Diego are usually between 60 and 73 loaded railcars.

Figure C.14: Transportation & Distribution - Truck



Pasha car carrier



Truck Unloading

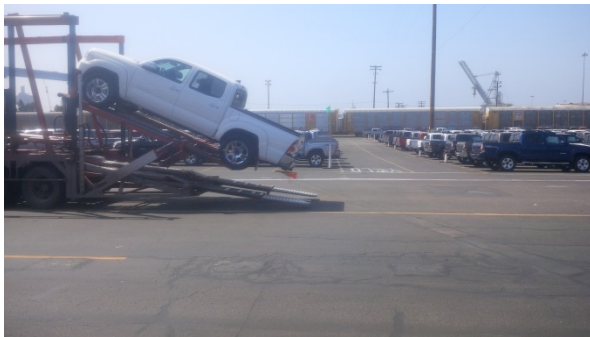

Lowering vehicle on truck



Empty car carrier exiting at BNSF Facility

Source: SD Freight Rail Consulting

Truck auto carriers typically carry eight to eleven vehicles. Final delivery to dealers, short distance inter-terminal shuttle, and short haul moves (<500 miles) are usually done by truck.

Vehicles are driven onto trucks and lifted or positioned using hydraulically operated ramps. Truck drivers move the vehicles on and off of the car carriers.

Figure C.15: Processing



Source: SD Freight Rail Consulting

Processing encompasses value added services to vehicles before they are shipped to dealers. This can include inspection, installation of options, and minor repairs to transit related damage.

The major component of processing involves installation of custom options such as CD players, wheels, or trim. This activity is performed at labor intensive processing centers rather than automated assembly plants due to the vehicle specific work required.

Figure C.16: Vehicle storage



Lot storage a vehicles



Inventory process in storage lot

Source: SD Freight Rail Consulting

This holding of cars can be done by densely packed such as for rail or less dense arrangements for picking of individual vehicles for truck-away to dealers. Typically storage is 150 to 200 vehicles per acre.

Data

The freight movements through the San Diego vehicle logistics facilities are shown below:

Figure C.17: Freight Movements Through San Diego Vehicles Logistics Facilities

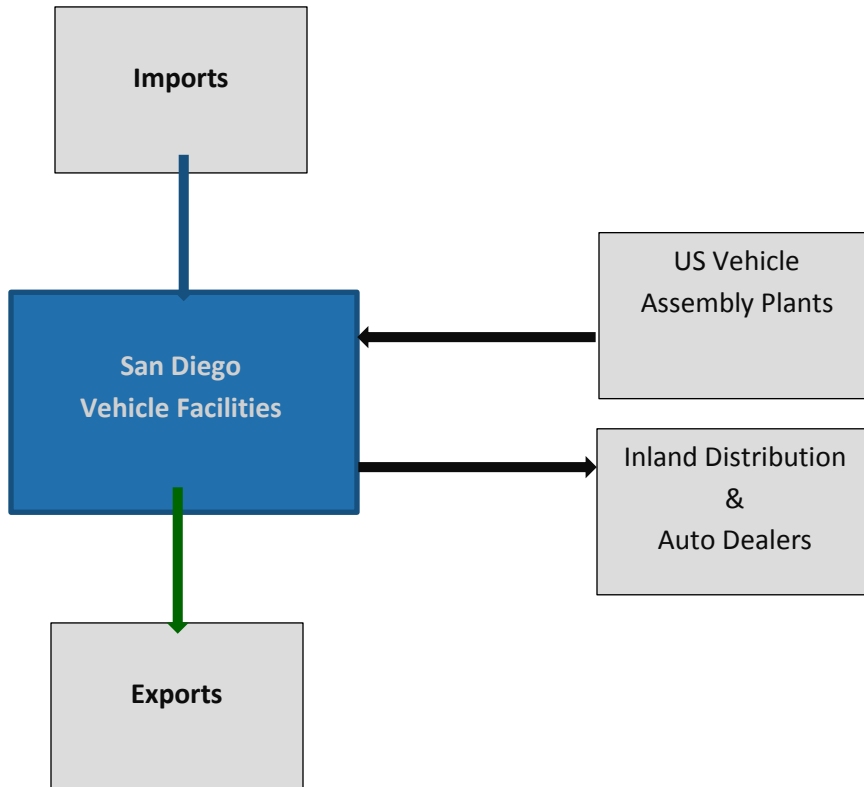

Source: SD Freight Rail Consulting

In terms of US Customs District vehicle volumes (border and seaport), the San Diego Customs District ranks 8th in imports, 12th in exports, and 9th in total volume.

Imports

The San Diego customs District imported 313,294 vehicles in 2014. The country of origin is shown in the chart below:

Figure C.18: 2014 San Diego Imported Vehicles by Origin

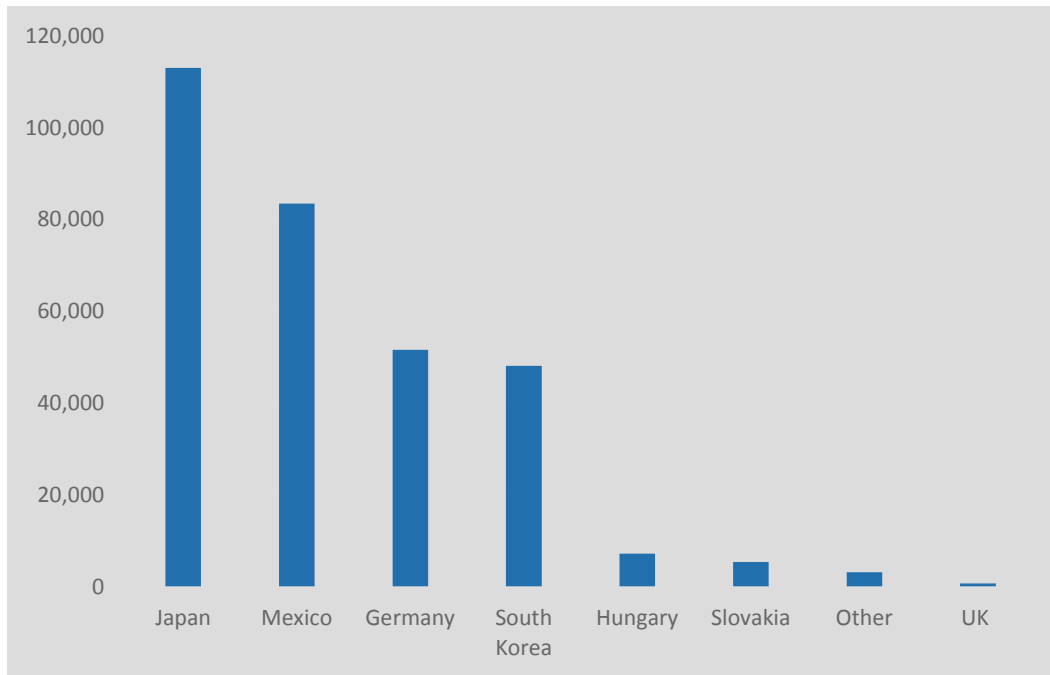

Source: U.S. Census

The major brands by country of origin are as follows:

- Japan – Mazda, Honda
- Mexico – Toyota (Tecate Plant), Volkswagen (Puebla Plant), by water, truck or rail
- Germany – Volkswagen
- South Korea – Hyundai/Kia

The mode of transportation for San Diego vehicle imports is shown in the chart below:

Figure C.18: 2014 San Diego Imported Vehicles by All Ports

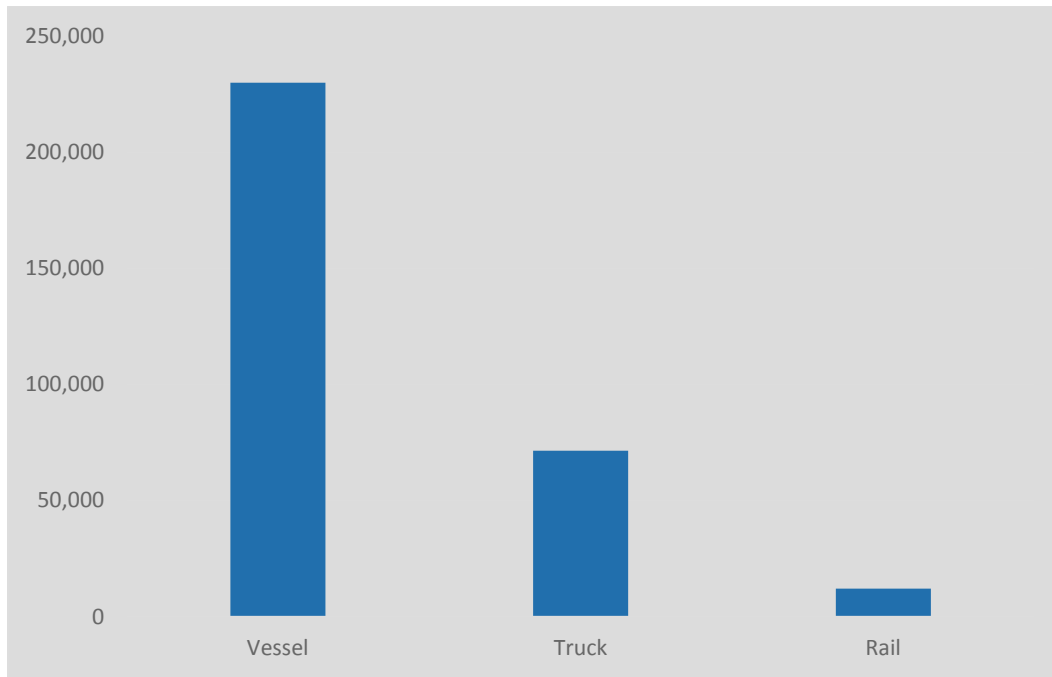

Source: U.S. Census

Exports

Vehicle exports from San Diego are well below the import vehicle volumes. There were 33,929 vehicles exported from the San Diego Customs District in 2014. The majority of these were US manufactured vehicles exported to Asia.

Figure C.19: 2014 San Diego Imported Versus Exported Vehicles

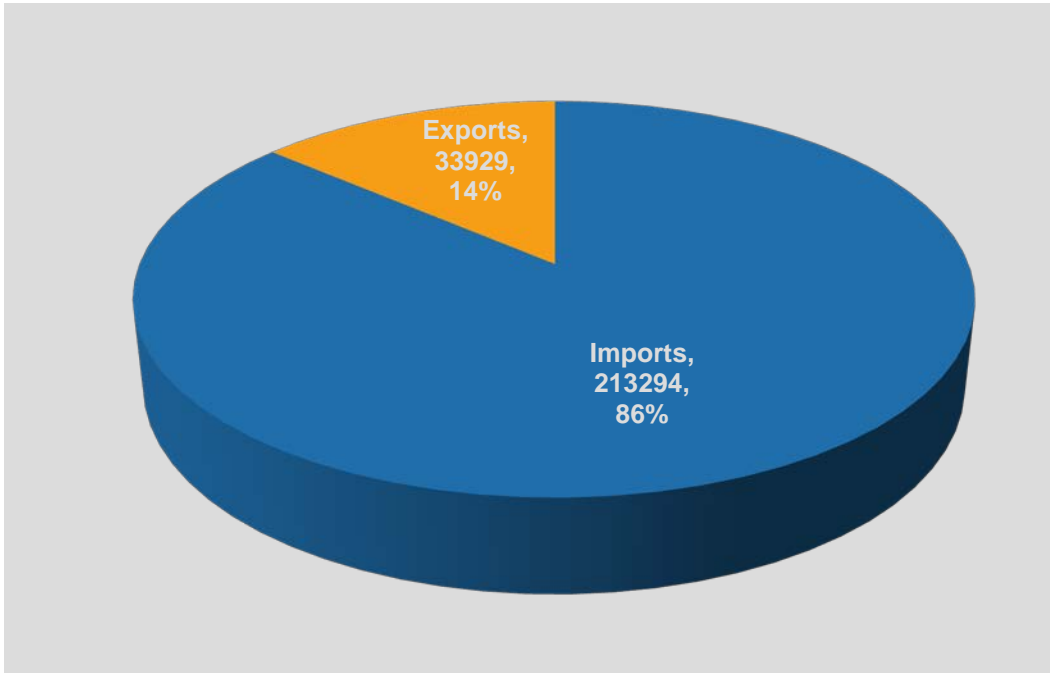

Source: U.S. Census

Figure C.20: 2012 San Diego Inbound Vehicles by Truck Origins

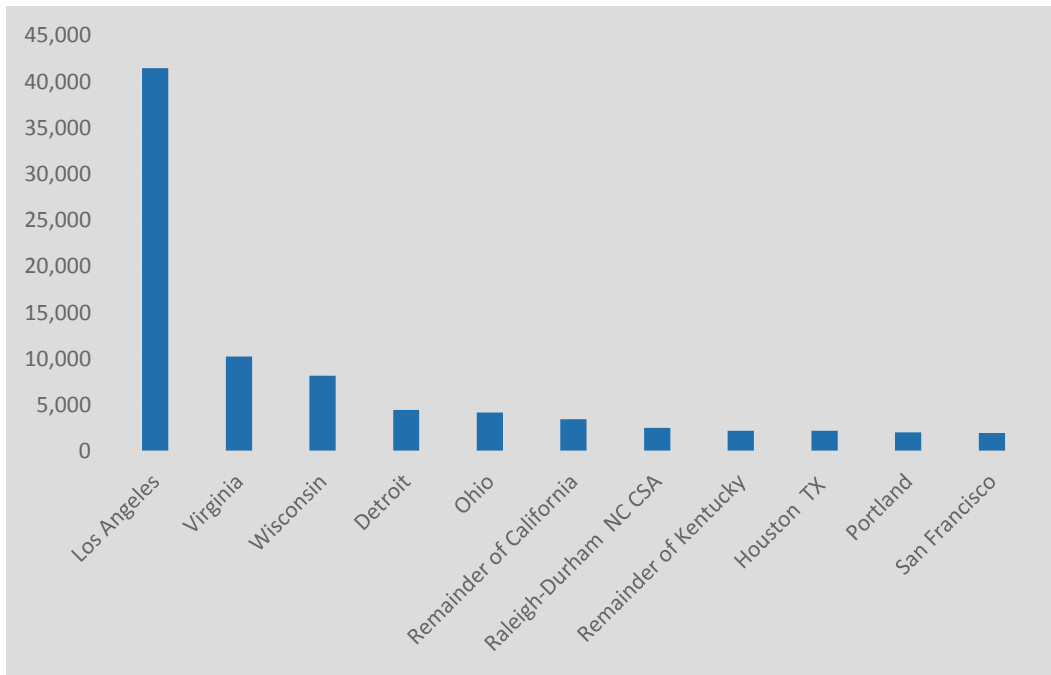

Source: FAF 3.5

FAF3 data has estimates of approximately 100,000 vehicles trucked into San Diego County.

The majority of the Los Angeles volume is delivery to dealers from the inbound rail heads at Mira Loma (UP) and San Bernardino (BNSF), along with regional deliveries from the Ports of LA and Long Beach.

Figure C.21: 2012 San Diego Outbound Truck Distribution

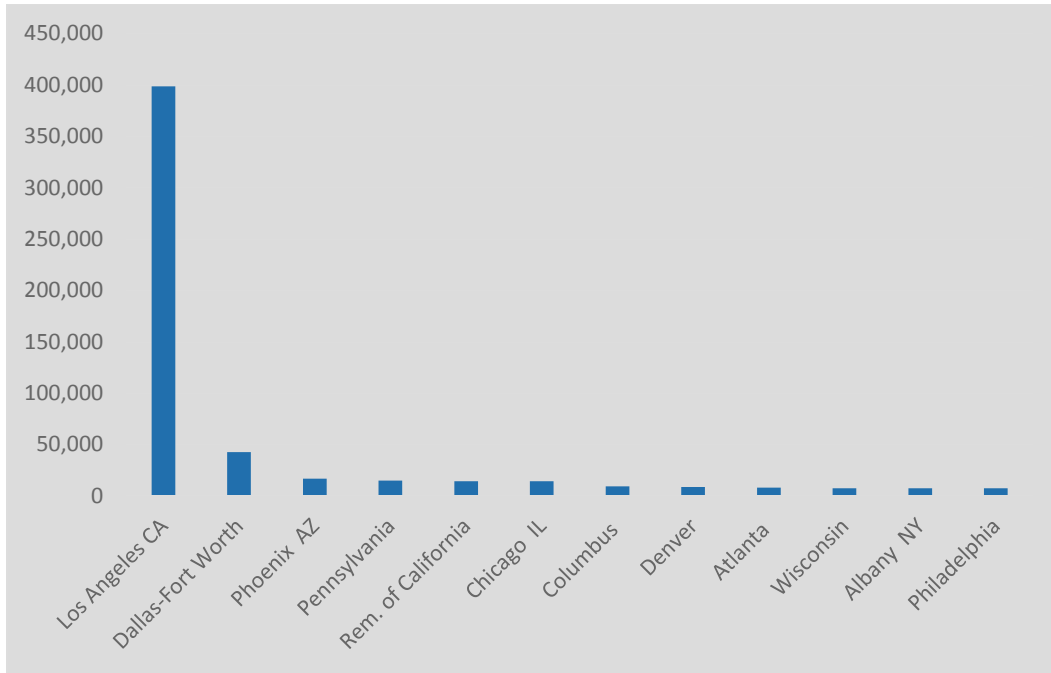

Source: FAF 3.5

The primary destination for outbound vehicles is San Diego and Los Angeles by truck. The remainder of California and Phoenix, AZ are also within a trucking radius of San Diego.

Rail moves to inland distribution centers have destinations of Fort Worth, Chicago, Denver, and other eastern terminals.

**APPENDIX D: FREIGHT GATEWAY STUDY UPDATE
ELECTRONICS IMPORT, EXPORT, AND DISTRIBUTION
2012 & 2013**



By:

SD Freight Rail Consulting

Introduction

Imports of Asian consumer electronics along with electronic components is a major component of Southern California imports, especially via container through the Ports of Los Angeles and Long Beach. These two ports have been the traditional gateway for Asian produced consumer products. This report shows the integration between San Diego and Los Angeles in accommodating this trade.

The electronics components moving through Los Angeles are primarily imported finished consumer electronics which are either consumed in the regions or forwarded for further repackaging and distributions throughout the entire United States.

The electronics components moving through San Diego are primarily electronic sub-components for export to the maquiladora industries in northern Baja California and finished consumer products from those same industries for distribution into the United States.

The following pages provide detailed data on the flows of electronics through the Los Angeles and San Diego gateway regions.

Regional Electronics Trade

Los Angeles is the major import point for electronics in southern California. San Diego serves as a cross-border import and export link for the Baja California maquiladora electronics assembly plants. Final distribution of both Asian imports and Mexico produced electronics is accomplished through distribution centers and intermodal facilities in the Los Angeles Basin.

Figure D.1: 2013 Regional Electronics Trade

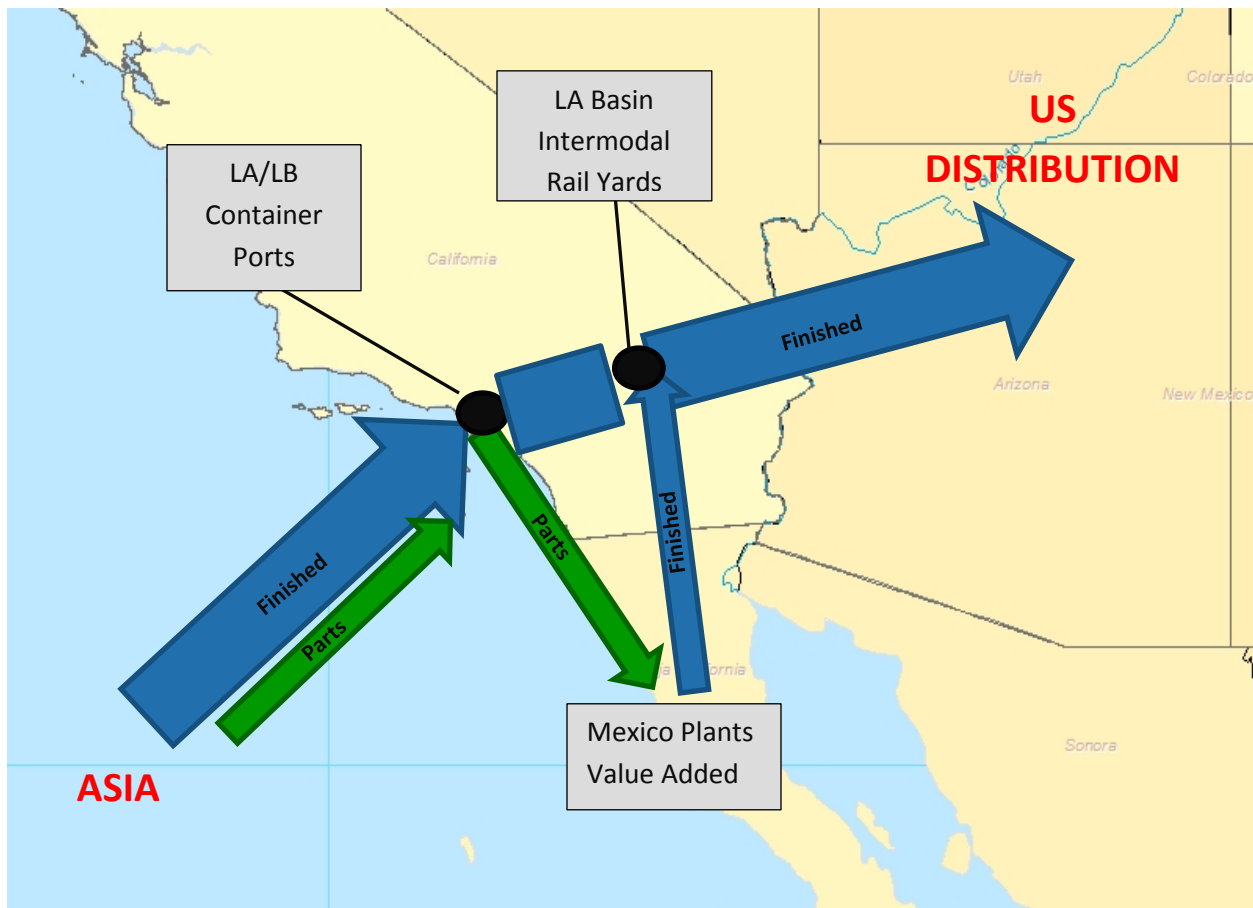

Source: SD Freight Rail Consulting

The majority of the imports are through the Ports of Los Angeles.

Figure D.2: 2013 Southern California Electronics Imports by Trade Value

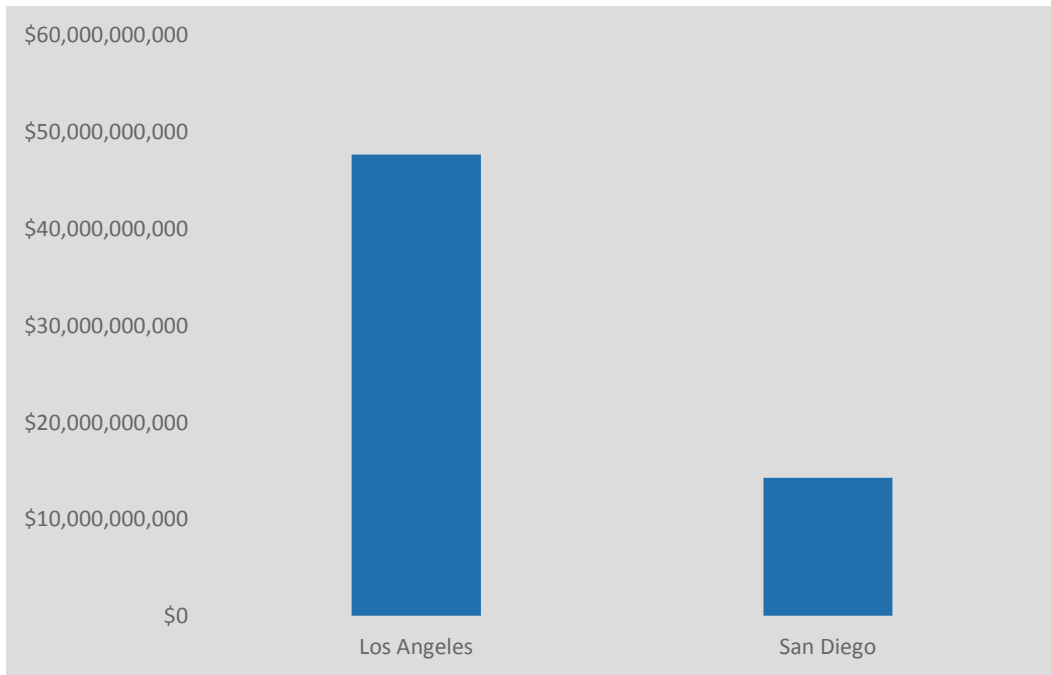

Source: FAF 3.5

Los Angeles

The major origin of electronics into Los Angeles is China. Additional volumes in much smaller value arrive from the Asian nations of Japan, Malaysia, Taiwan, South Korea, Thailand, and the Philippines.

Figure D.3: 2013 Los Angeles Electronics Imports by Country of Origin & Trade Value

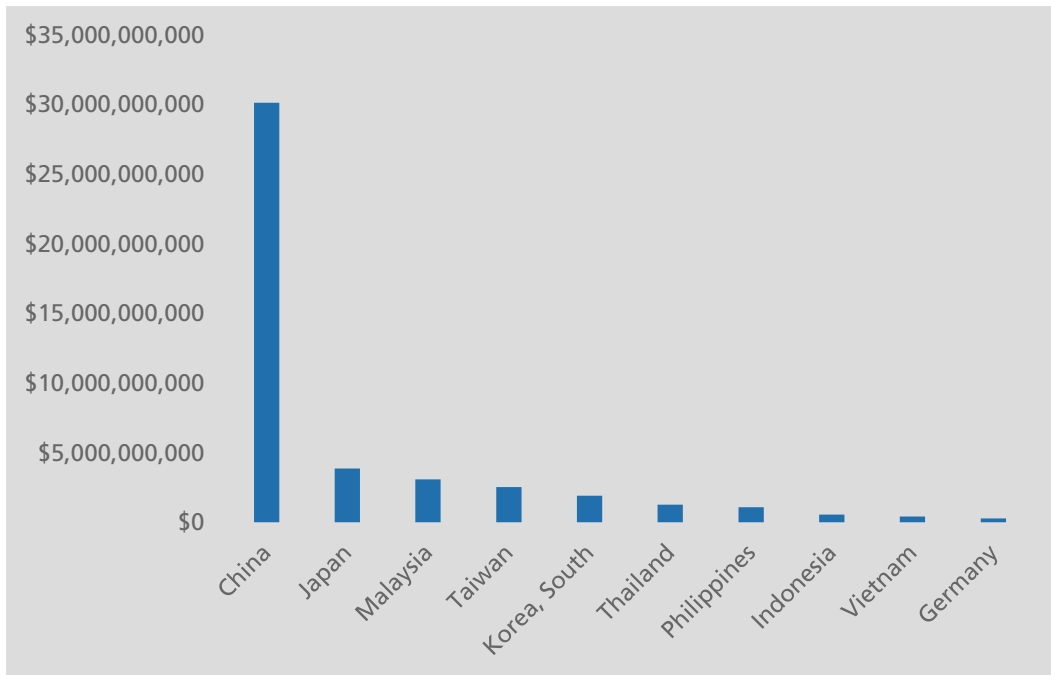

Source: FAF 3.5

The electronics imports into Los Angeles are predominantly display monitors and phones.

Figure D.4: 2013 Los Angeles Electronics Imports by Commodity Type & Trade Value

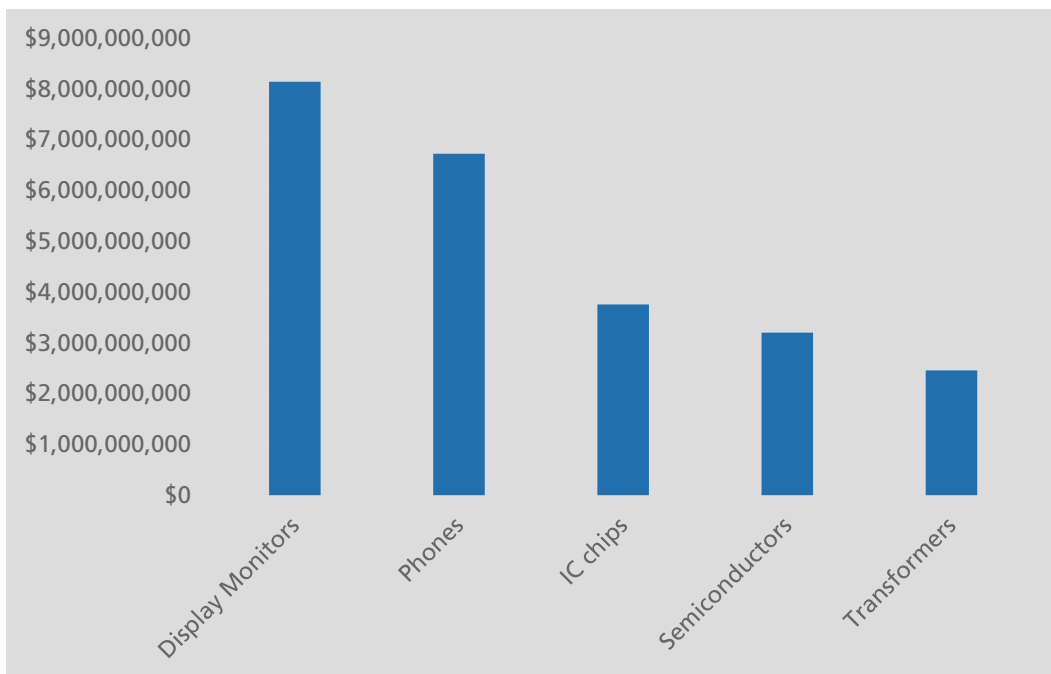

Source: FAF 3.5

San Diego

San Diego is an import point for electronics from Mexico, with few other imports due to the lack of container port and associated support facilities (warehousing and rail).

Figure D.5: 2013 San Diego Electronics Imports by Country of Origin & Trade Value

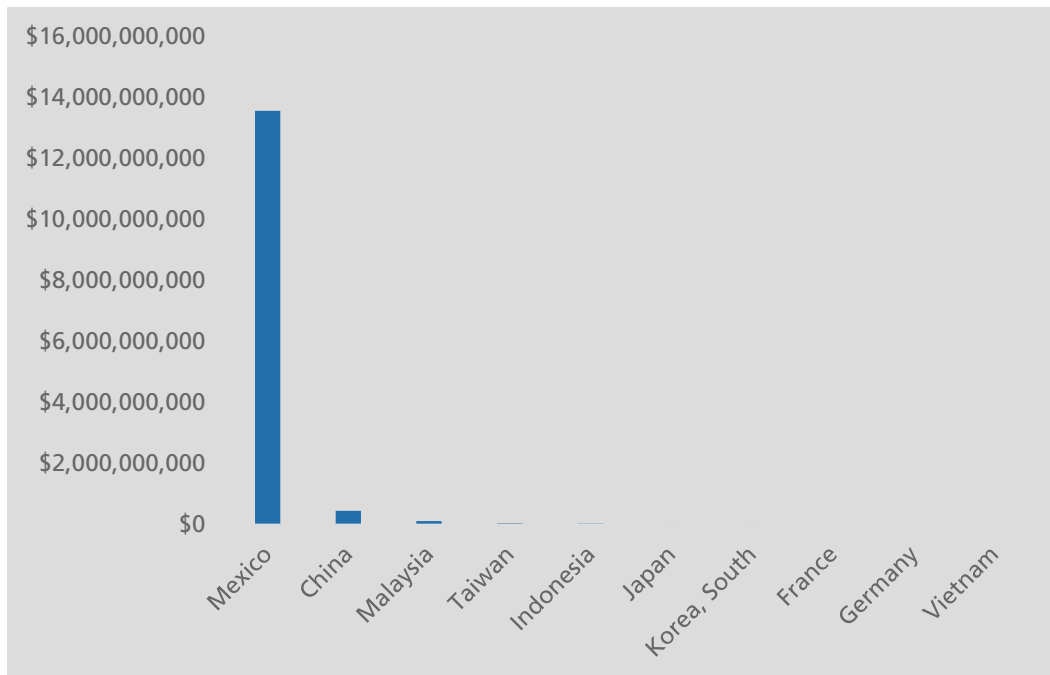

Source: FAF 3.5

San Diego is different in that there is a substantial export and import component for the crossborder move of electronics. The majority of the exports are component parts for maquiladora display assembly plants.

Figure D.6: 2013 San Diego Electronics Exports by Commodity Type & Trade Value

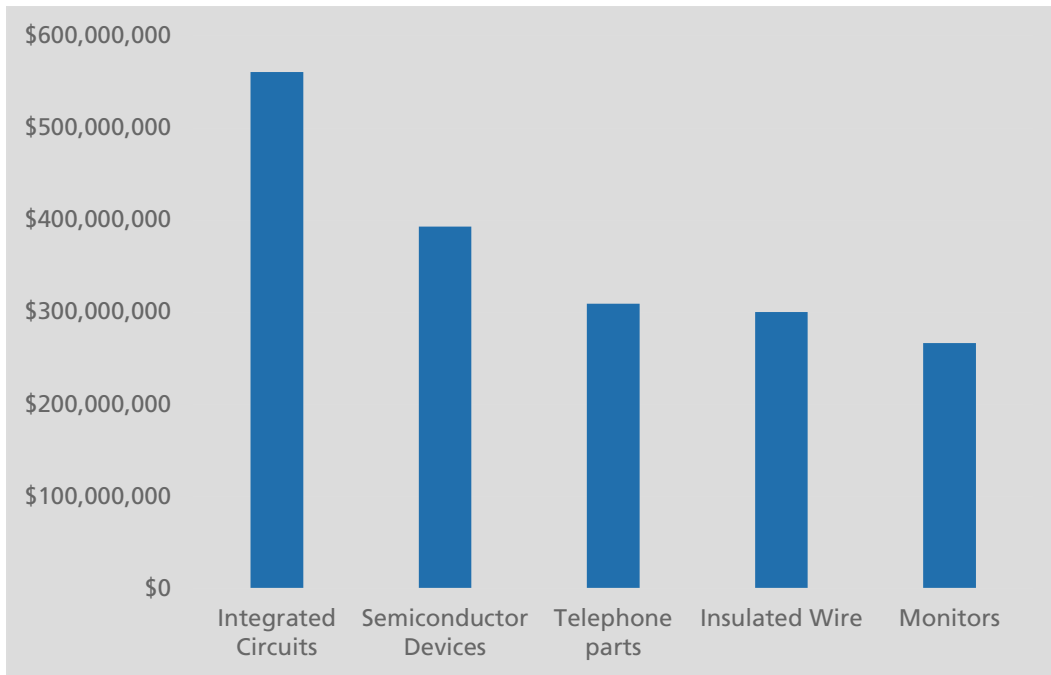

Source: FAF 3.5

Figure D.7: 2013 San Diego Electronics Imports by Commodity Type & Trade Value

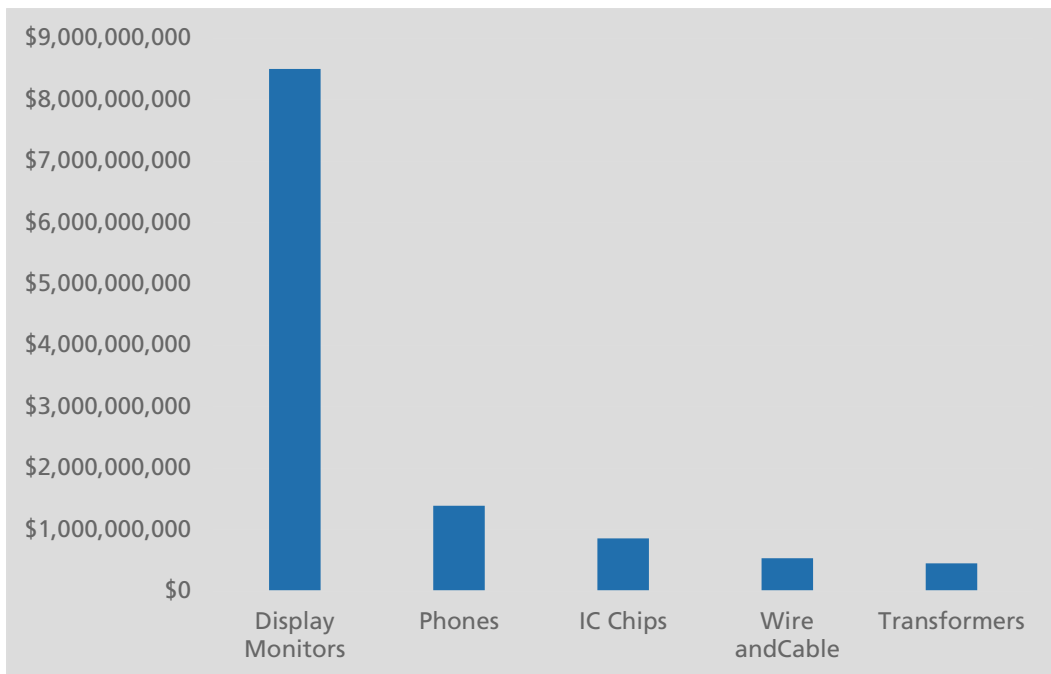

Source: FAF 3.5

The export and import values show the value added component of the maquiladora manufacturing of display monitors. The imported value of the finished products is greater than the exported value of the component parts.

Electronics Distribution

The electronics described in this report move almost entirely by intermodal container. The diagram on the following page shows the distribution elements in Southern California. Those elements are described below.

The ports of LA/LB serve as the initial point of entry where the electronics arrive. From this point, the containers are moved onto chassis and moved by a “drayage” truck hauler to the following types of facilities:

- Rail intermodal facility – this is a terminal where containers are removed from chassis and loaded onto intermodal rail cars for distribution into the US
- Cross-dock facility – an open warehouse where electronics and other material are transferred from a standard 40’ international container into a 53’ domestic container. The 40’ container is then usually returned empty to the Port while the 53’ container is moved to the rail intermodal facility or trucked directly to a destination in the Southern California region
- National Distribution Center/Regional Distribution Center (NDC/RDC) – these are large warehouses that typically are operated by “big box” retailers. The 40’ international containers are unloaded and the products stored within the warehouses. These 40’ containers are then usually returned empty to the Ports. The product in the warehouses is then mixed with other products for specific destinations and/or stores and then loaded into 53’ domestic containers. NDCs typically truck the containers to the rail intermodal facilities for further delivery to either RDCs or stores. RDCs usually truck directly to stores.

Figure D.8: Supply Chain Truck Transfer Options for Electronics Exclusive of Crossborder Trade

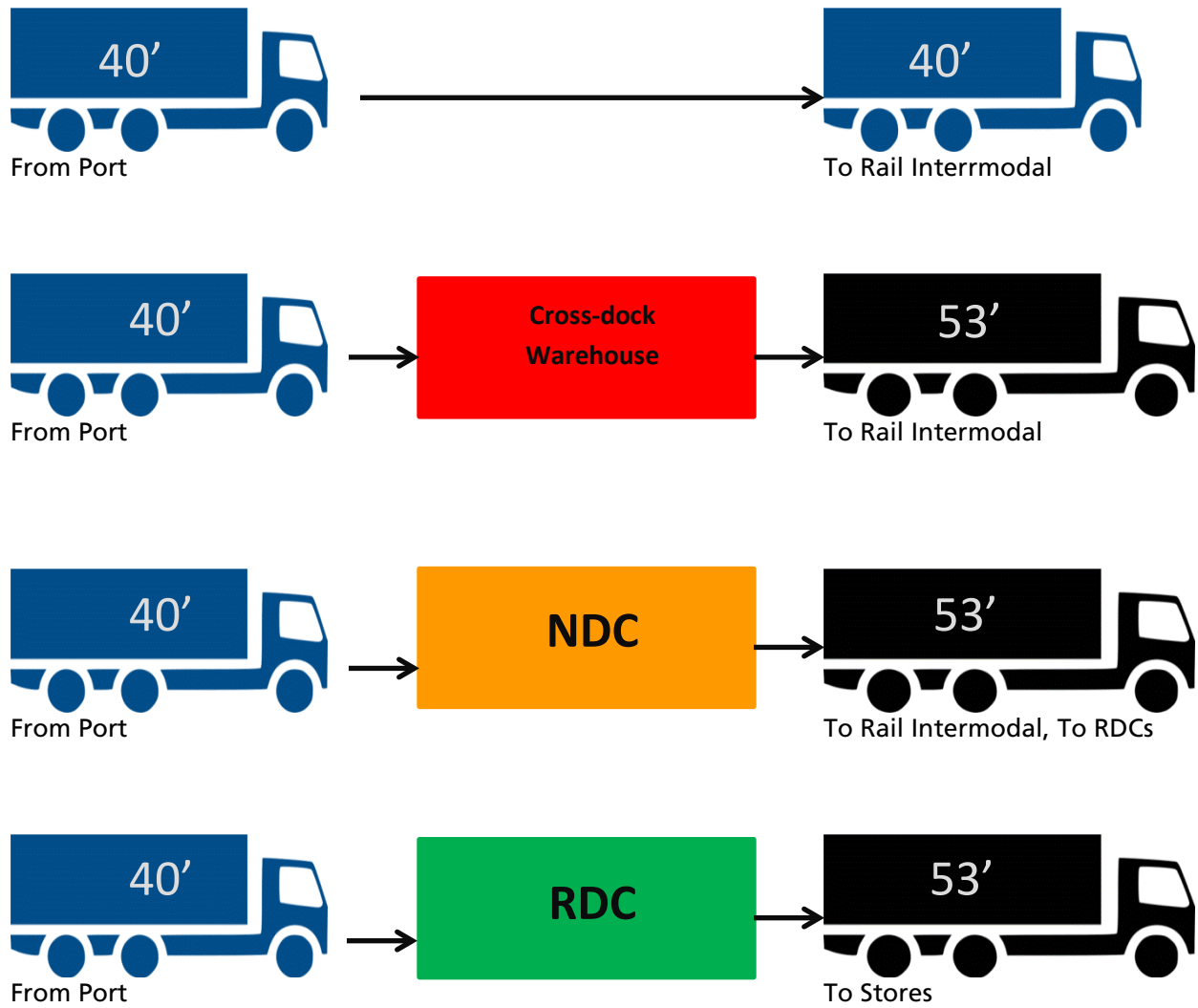

Source: SD Freight Rail Consulting

The activity at the border is shown in detail and includes warehousing and trucking distribution which functions similar to the activity in the Los Angeles Basin.

Figure D.9: Los Angeles Basin/San Diego Truck Distribution Interdependency

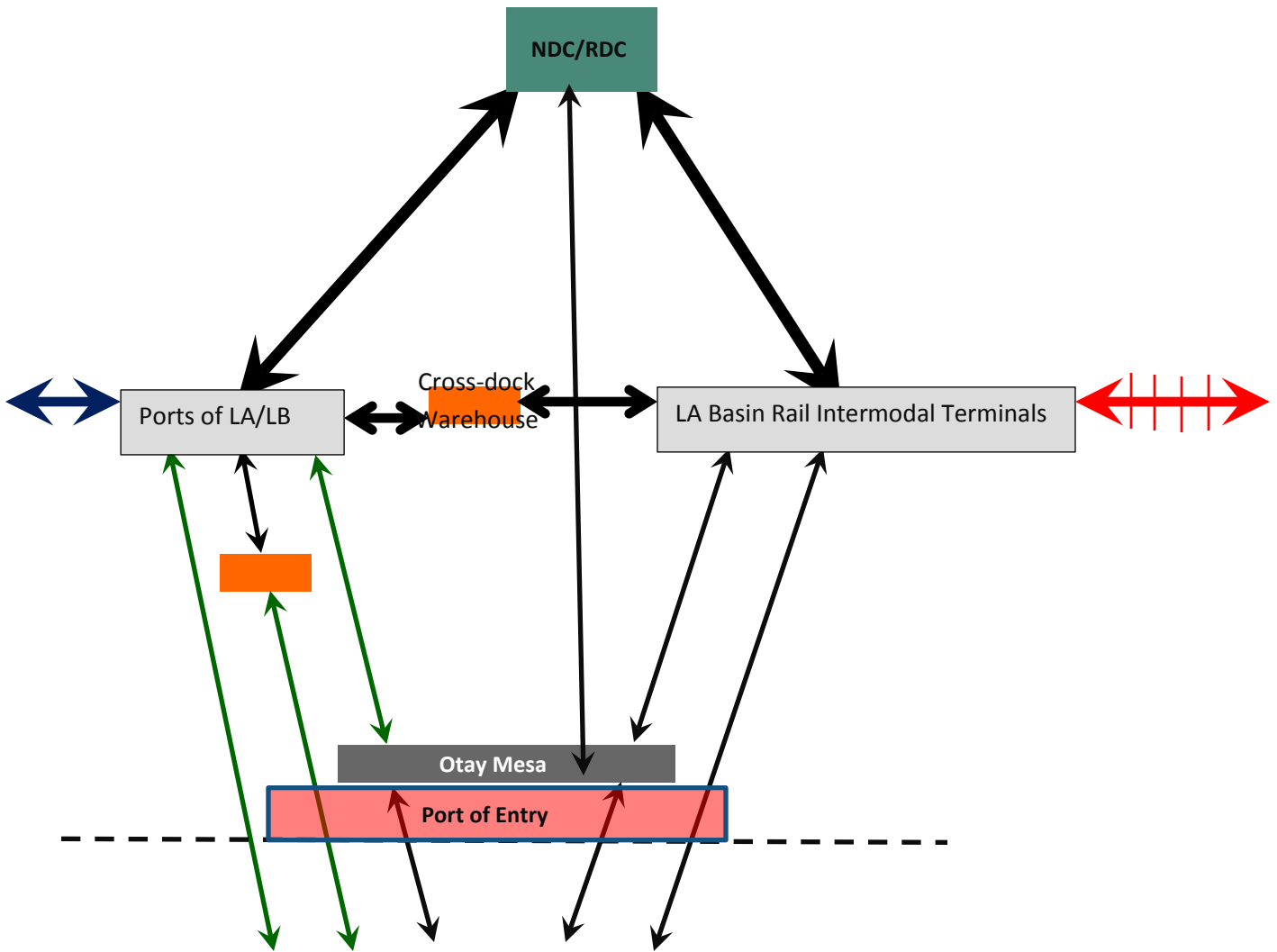

Cross-Border Truck Flows

The two major truck border crossings which handle the Baja California maquiladora electronics trade are Otay Mesa in San Diego County and Calexico East in Imperial County. The majority of both imports and exports cross at Otay Mesa.

Figure D.10: 2013 Regional Truck Gateways Border Electronics Imports by Trade Value

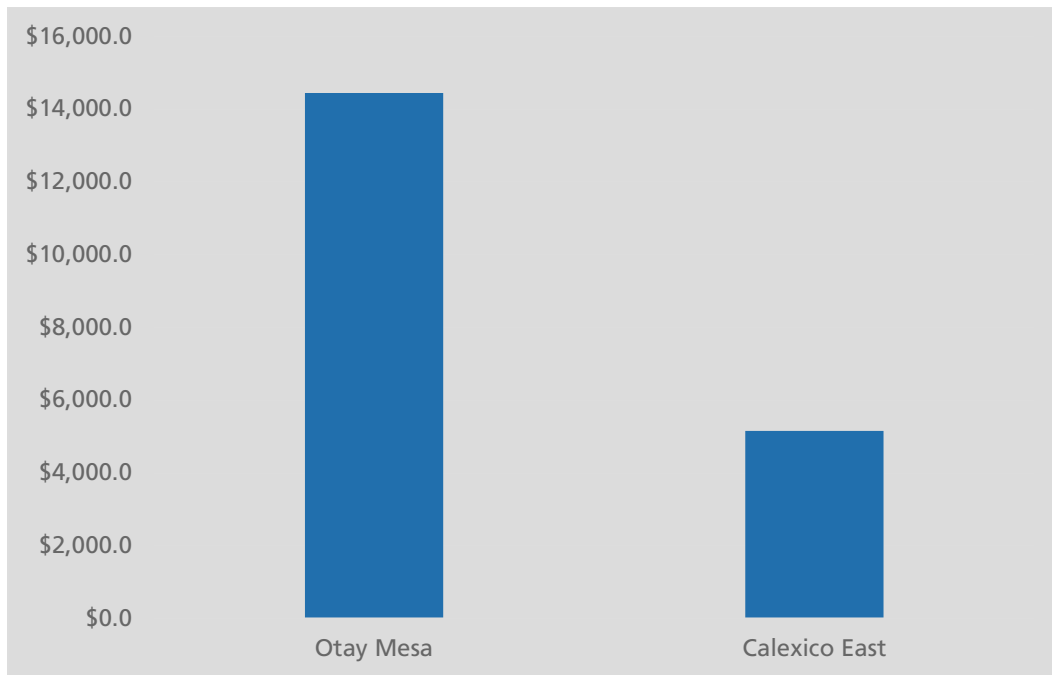

Source: FAF 3.5

Figure D.11: 2013 Regional Truck Gateways Border Electronics Exports by Trade Value

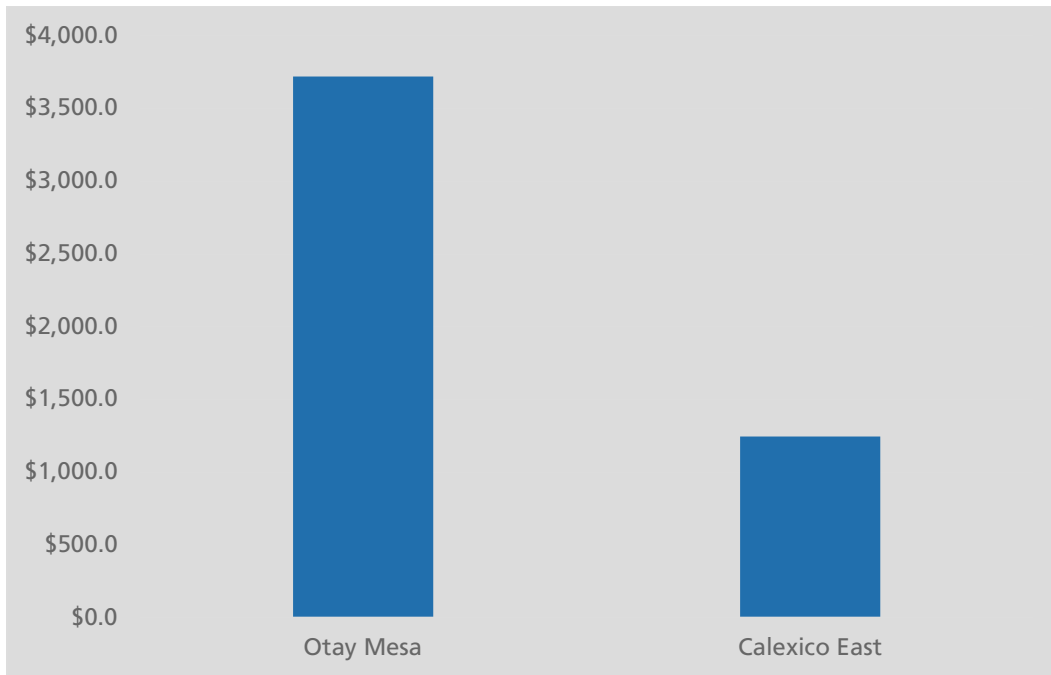

Source: FAF 3.5

Electronics Distribution Flows

The majority of the import electronics flows in FAF moving through either Los Angeles or San Diego have a termination in California. However much of this volume is transshipped via warehousing and other containers and has an ultimate destination outside of California.

Figure D.12: 2013 Los Angeles Electronics Imports Destinations by Value

State	2013 Value \$M
California	\$30,407
Texas	\$9,998
Tennessee	\$6,058
Illinois	\$4,157
New Jersey	\$2,705
New York	\$1,816
Missouri	\$1,506
Ohio	\$1,502
Indiana	\$1,221
North Carolina	\$1,002

Source: FAF 3.5

Figure D.13: 2013 San Diego - Mexico Electronics Imports Destinations by Value

State	2013 Value \$M
California	\$14,154
New York	\$321
Pennsylvania	\$254
Massachusetts	\$199
Texas	\$188
Minnesota	\$126
Wisconsin	\$105
Illinois	\$94
New Jersey	\$69
Arizona	\$67

Figure D.14: Los Angeles Imports US Distribution Outside California

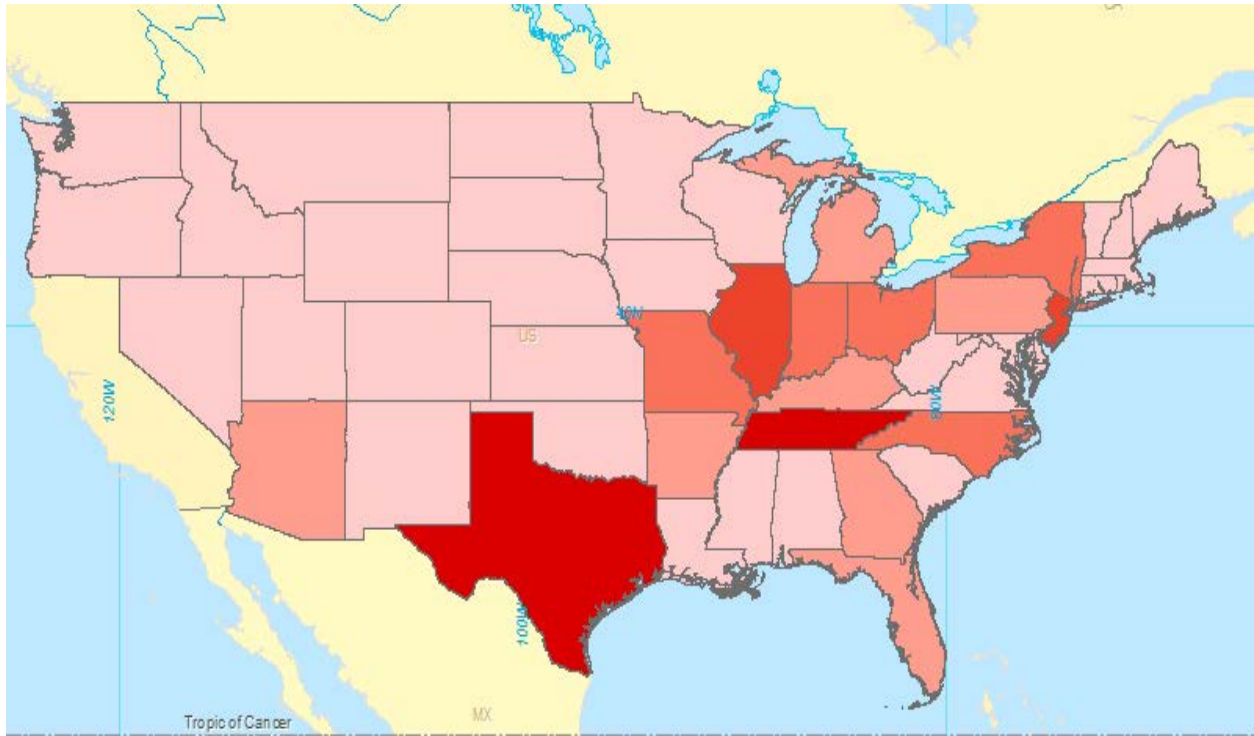

2013 Value (\$M)	State Propensity
0-10	
10-50	
50-100	
100-250	
2500-500	

Figure D.15: San Diego Mexican Imports US Distribution Outside California

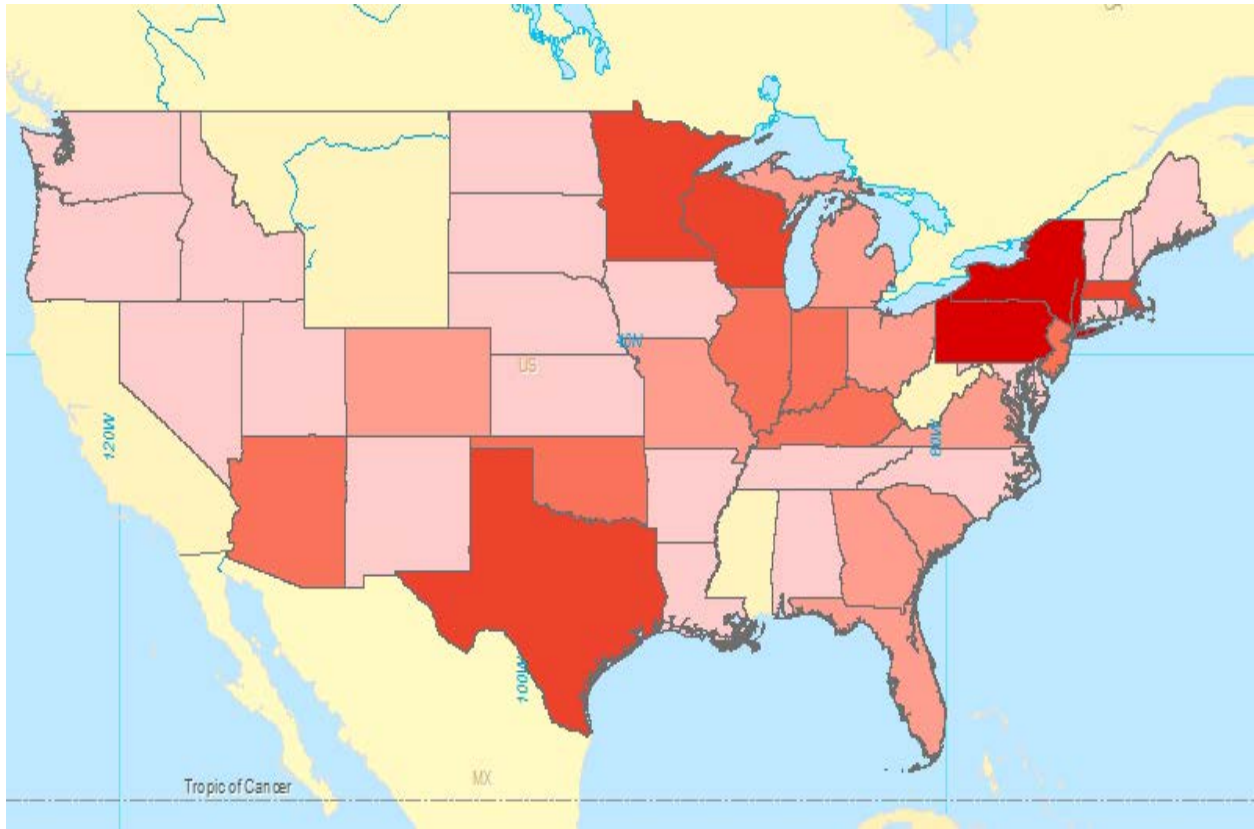

2013 Value (\$M)	State Propensity
0-500	
500-1000	
1000-2500	
2500-5,000	
5,000-10,000	

APPENDIX E: FREIGHT GATEWAY STUDY UPDATE REGIONAL FRUIT AND MEAT IMPORT, EXPORT, AND DISTRIBUTION 2012 - 2014



By:

SD Freight Rail Consulting

Introduction

This study looks at three commodities which move through San Diego; imported fruits, exported meat and poultry to Mexico, and imported seasonal strawberries.

Advances in refrigeration and preservation techniques have led to the year round consumption of specialized fruits and worldwide distribution of meat and poultry. The loosening up of trade restrictions has also served to increase the market for both imported fruit and exported meats.

San Diego being both a seaport city and a border crossing is uniquely situated to take advantage of these positive trends. In recent years, the Port of San Diego has been able to land a distribution center operated by Dole, the largest worldwide producer and marketer of bananas. And local cold storage facilities have grown to serve an increasing demand for pork and chicken in Mexico. The same facilities also serve to hold seasonal fruits grown in Mexico which can fill the year round demand for California produced fruit during the winter season for California growers.

A full understanding of these markets and distribution components are important for developing enabling infrastructure plans to support the existing freight volumes and future growth.

This study will be divided into two market segments; the U.S. market, and then examine in detail sections of the San Diego refrigerated meat and fruit transportation market. It will also cover the local facilities and equipment required to support the market.

Markets

The predominant trades discussed in this paper are the imported fruit, primarily bananas, from Central and South America, and exported meat, primarily chicken and pork to Mexico.

Figure E.1: Fruit and Meat Imports and Exports from and to the San Diego Region



Source: SD Freight Rail Consulting

Using the general categories in the Freight Analysis Framework, the general scale of San Diego trade vs. the remainder of the United States is shown below.

Some of the datasets used in this study are limited to the general commodity categories of “fruit” and “meat.” FAF3 is in this category. FAF3 is used to establish origins and destinations within the United States. Transborder Freight is used to establish commodity moves by value crossing at the border. U.S. Army Corp Waterborne Commerce contains tonnage by each Port.

U.S.A Trade Data and the USDA datasets are more specific with commodities and have detailed data on bananas, pineapples, strawberries, chicken, and pork.

The study contains both high level aggregate and specific commodity information using both types of datasets.

National Trade Patterns

Figure E.2: 2012 Waterborne Fruit Imports by FAF 3.5 Zone and by Tons

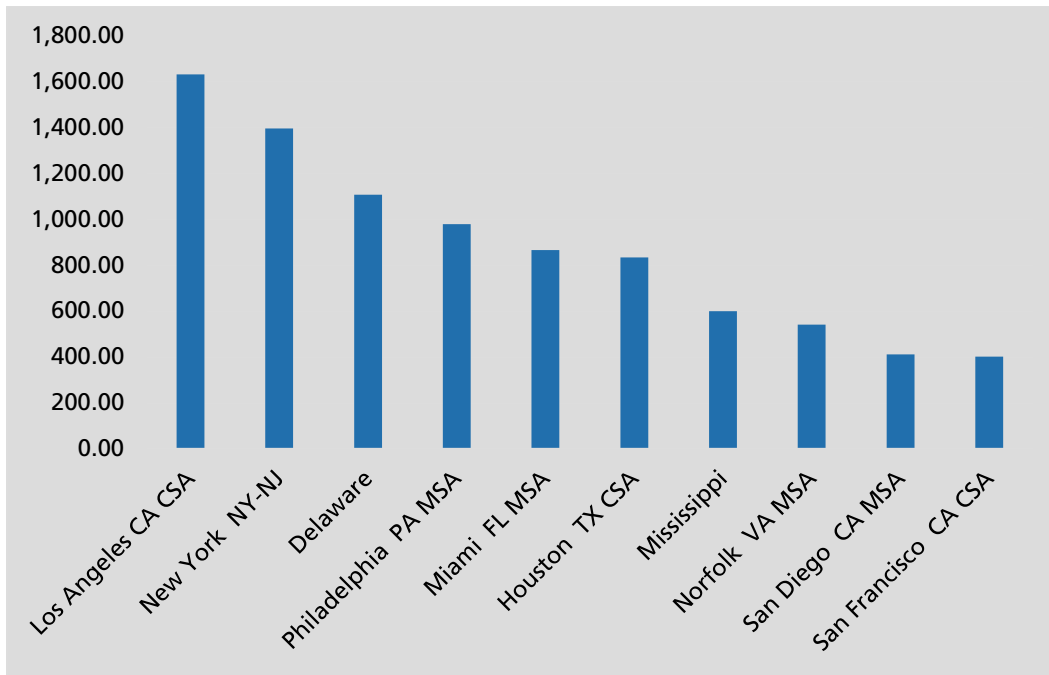

Source: FAF 3.5

San Diego ranks 9th in U.S. fruit imports by water. On the U.S. West Coast, San Diego is the second largest import Port behind Los Angeles/Long Beach/Port Hueneme.

In terms of fruit tonnage on West Coast Ports, Figure E.3 gives the breakdown.

Figure E.3: 2012 West Coast Banana Imports by Port and by Tons

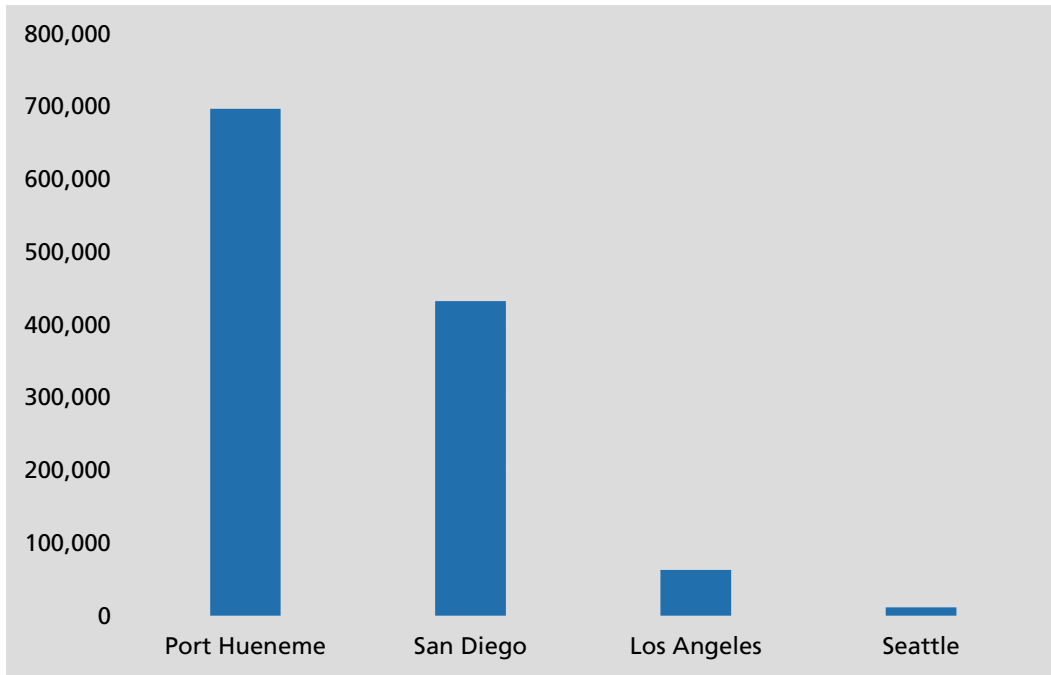

Source: U.S. Army Corps of Engineers

Bananas

Bananas are one of the world’s most important crops. Banana production in the United States is small; therefore, the vast majority of United States consumption is imported. The United States typically consumes 3.5 – 4.0 million metric tons of bananas per year.

Figure E.4: 2009 - 2014 U.S. Fresh Banana Imports by 1,000 lbs.

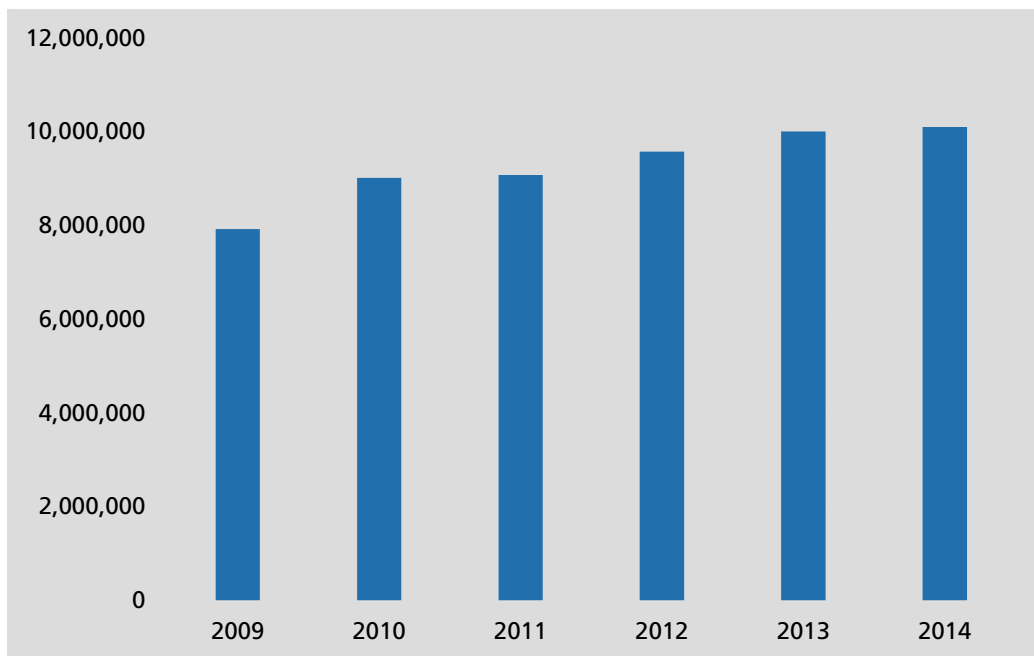

Source: U.S. Department of Agriculture

The major suppliers of bananas to the U.S. market are Guatemala, Ecuador, Costa Rica, Colombia, and Honduras.

Figure E.5: 2014 Top Fresh Banana Exporters to the United States by 1,000 lbs.

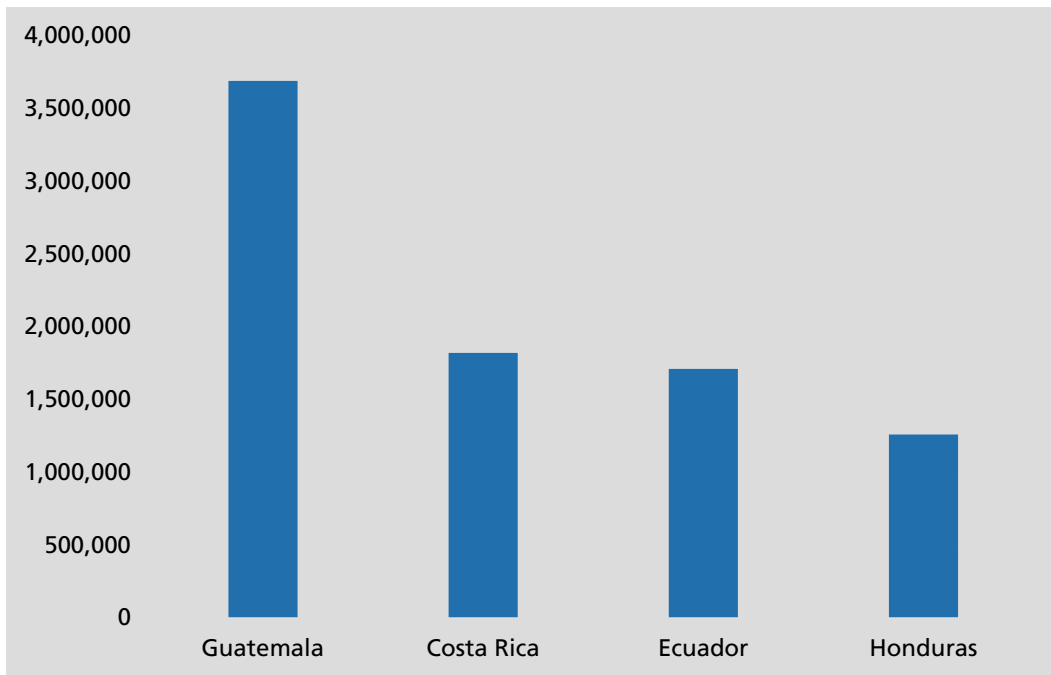

Source: U.S. Department of Agriculture

The largest transnational banana producers and marketers in order of market size are Dole (19%), Chiquita Brands (17%), and Del Monte Fresh Produce (14%). The West Coast distribution center for Dole is San Diego while Chiquita and Del Monte use Port Hueneme.

Strawberries

Strawberries are a major menu item and are usually consumed fresh. They are also processed to be used in jams and jellies. Strawberries are the fourth most valuable fruit crop in the United States. The United States ranks first in the world for strawberry production, followed by China and Spain. The leading strawberry-producing states are California, Florida, Oregon, North Carolina, Washington, Pennsylvania, Michigan, Wisconsin, New York, and Ohio. California is the largest producer but the production is seasonal. Eighty-two percent of United States imported strawberries are from Mexico.

Figure E.6: 2009 - 2014 U.S. Strawberry Imports by 1,000 lbs.

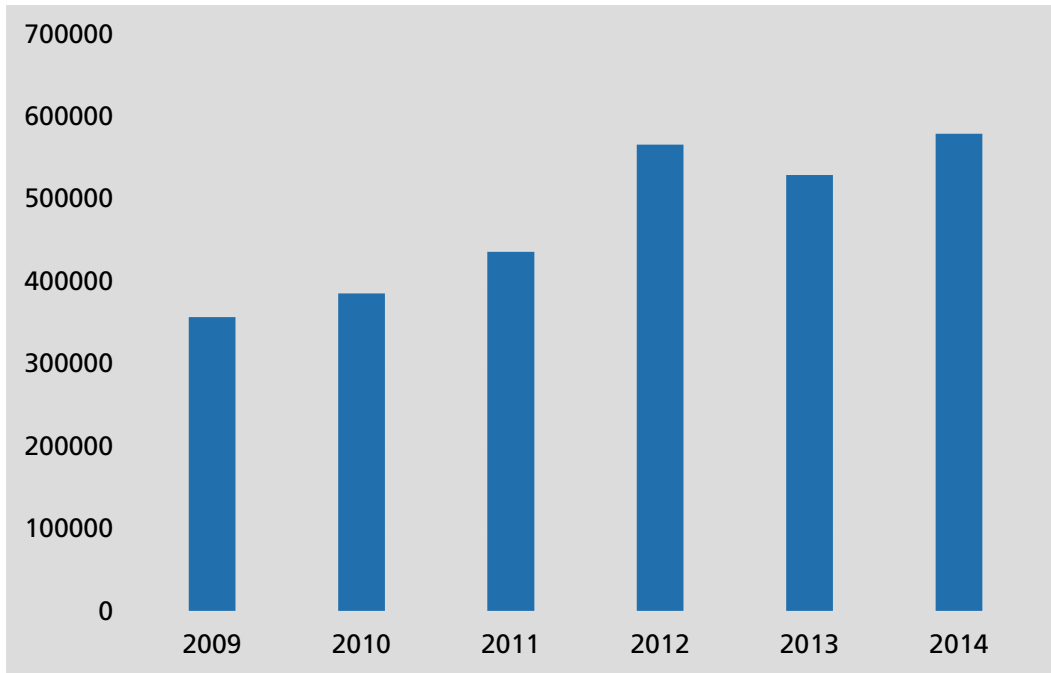

Source: U.S. Department of Agriculture

To make up for lost volumes during the winter month's strawberries are imported from Mexico through San Diego. Facilities within San Diego serve as transshipment and processing points for strawberries during these months.

Figure E.7: 2014 U.S. Strawberry Imports by lbs.

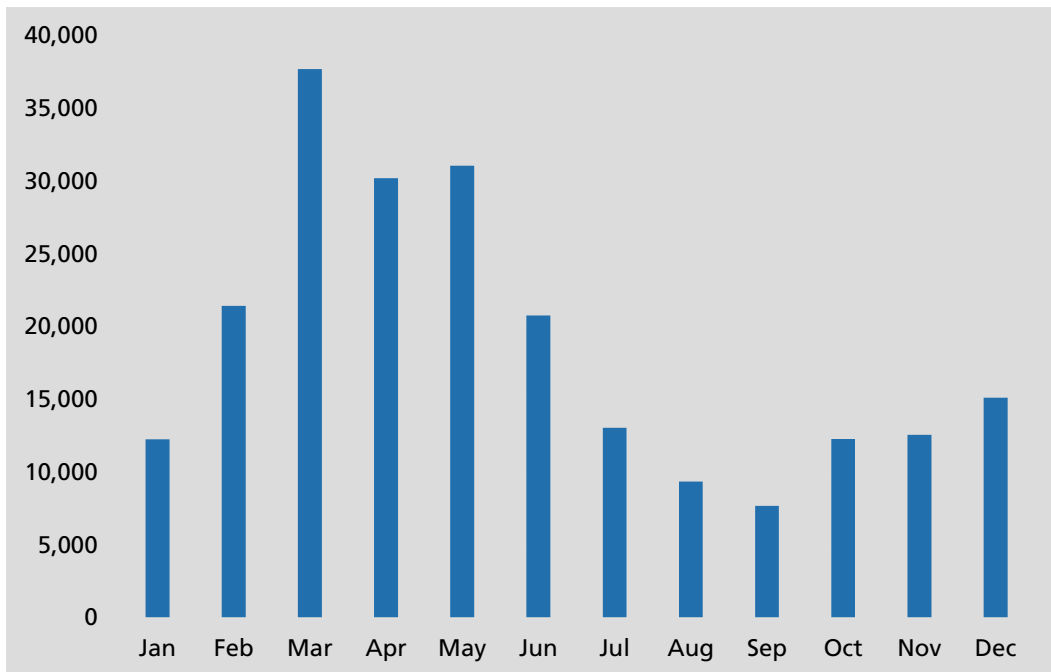

Source: U.S. Department of Agriculture

Exported Meat to Mexico

Trade liberalization and a growing population with the ability to purchase higher end menu items has resulted in an increase of meat consumption in Mexico.

Exports of meat and poultry products by truck to Mexico over the U.S. border are shown below:

Figure E.8: 2014 Truck to Mexico Meat Exports by Land Port and by Trade Value

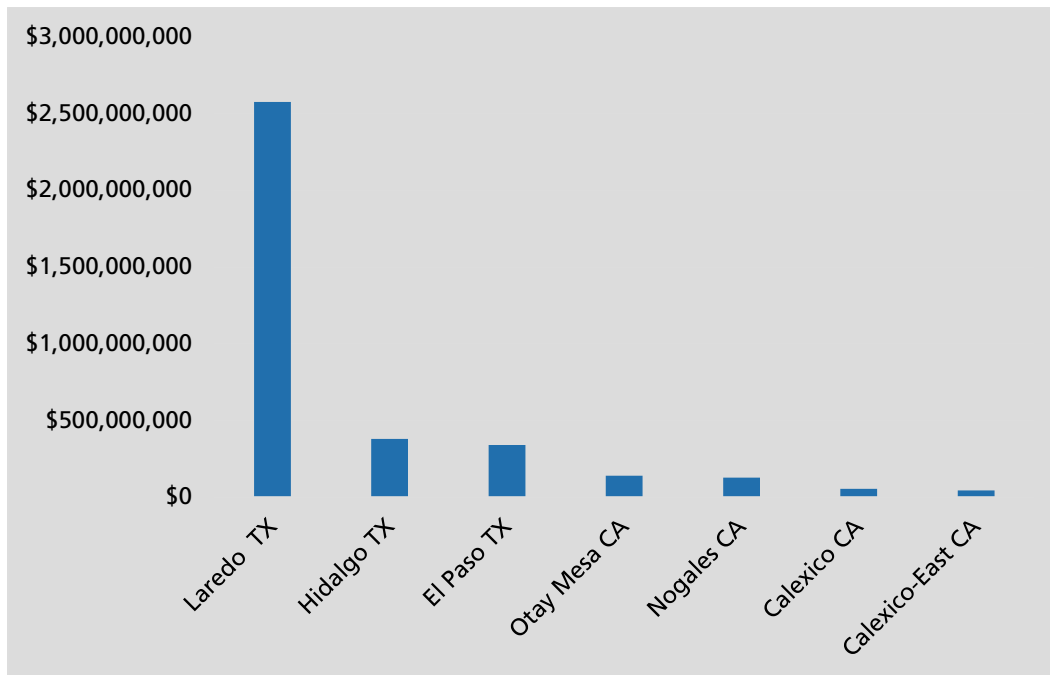

Source: Transborder Freight

The majority of the volume by value is moved across the border at Laredo, TX. Otay Mesa ranks fourth among border crossings for movement of meat and poultry by truck to Mexico. The San Diego portion represents 3.7% of the total cross border meat and poultry exports to Mexico.

This split is primarily due to the smaller population which is served in the remote northwest area of Mexico in Baja California versus the more populous Mexico states located south and within proximity of the Texas border.

Chicken

Figure E.9: 2008 - 2014 United States to Mexico Chicken Exports by 1,000 lbs.

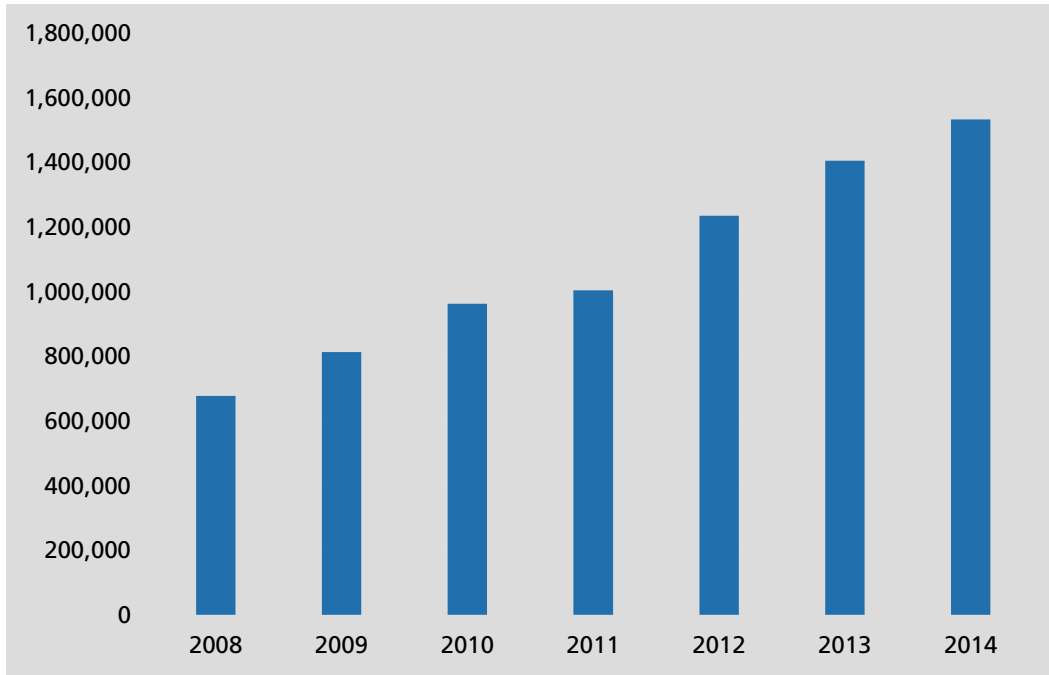

Source: U.S. Department of Agriculture

Pork

Figure E.10: 2008 - 2014 United States to Mexico Pork Exports by 1,000 lbs.

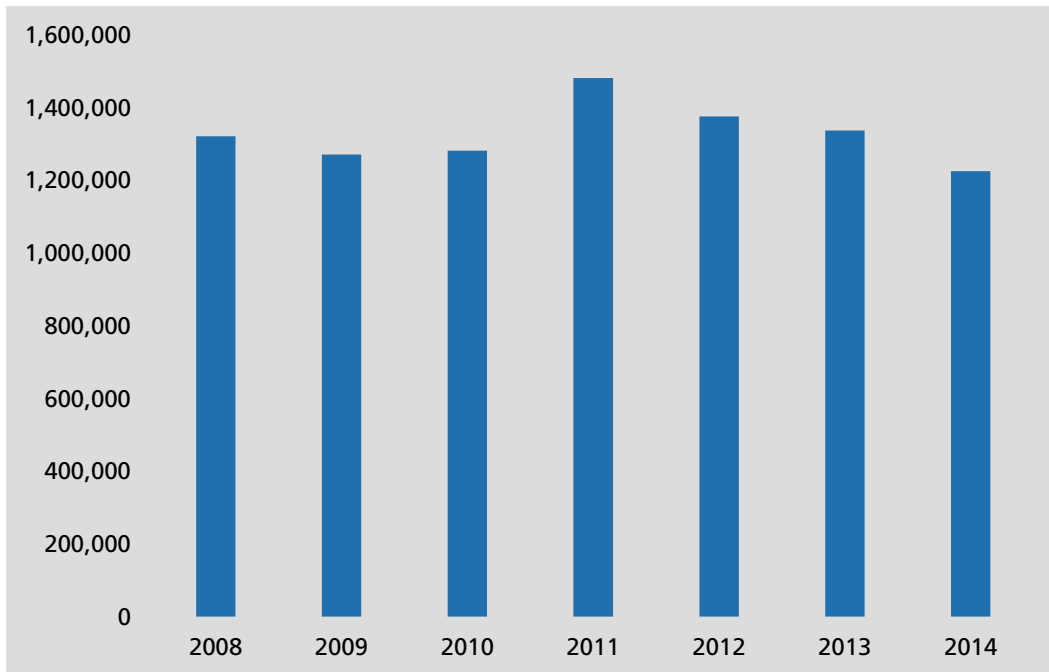

Source: U.S. Department of Agriculture

San Diego Trade Patterns

Imported Fruit

Figure E.11: 2012 All Fruit Imports Through San Diego Seaport and Land Ports

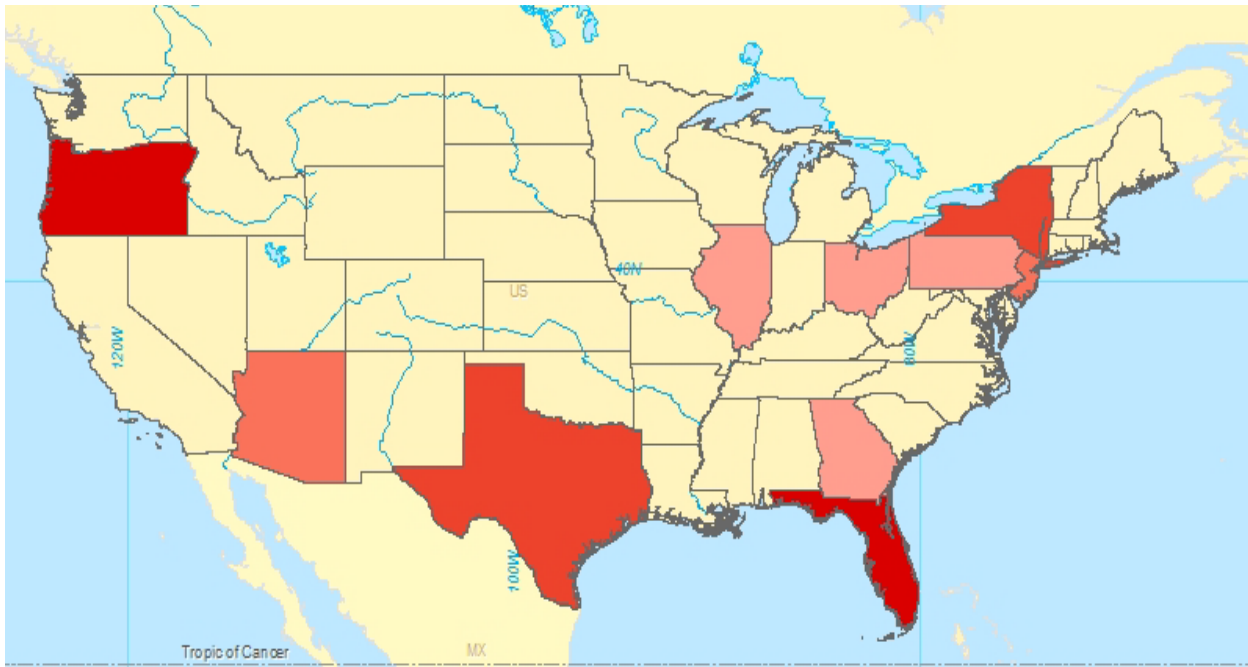

Source: FAF 3.5

Eighty-nine percent of the fruit imported through San Diego is destined to California destinations. The remaining destinations are highlighted in the map above. The largest destinations by volume are shown in the chart below:

Table E.1: 2012 All Fruit Imports Destinations Through San Diego by Tons

State	2012 Ktons
Oregon	73.3487
Florida	42.0159
Texas	17.4061
New York	14.1121
Arizona	8.7792
New Jersey	6.9562
Illinois	1.6211
Pennsylvania	1.2203
Ohio	1.1367
Georgia	1.0095

Source: FAF 3.5

Strawberries and other fruit are imported from Mexico. The primary truck crossing is Otay Mesa.

Figure E.12: 2007 - 2014 San Diego and Imperial Fruit Imports by Truck and by Trade Value

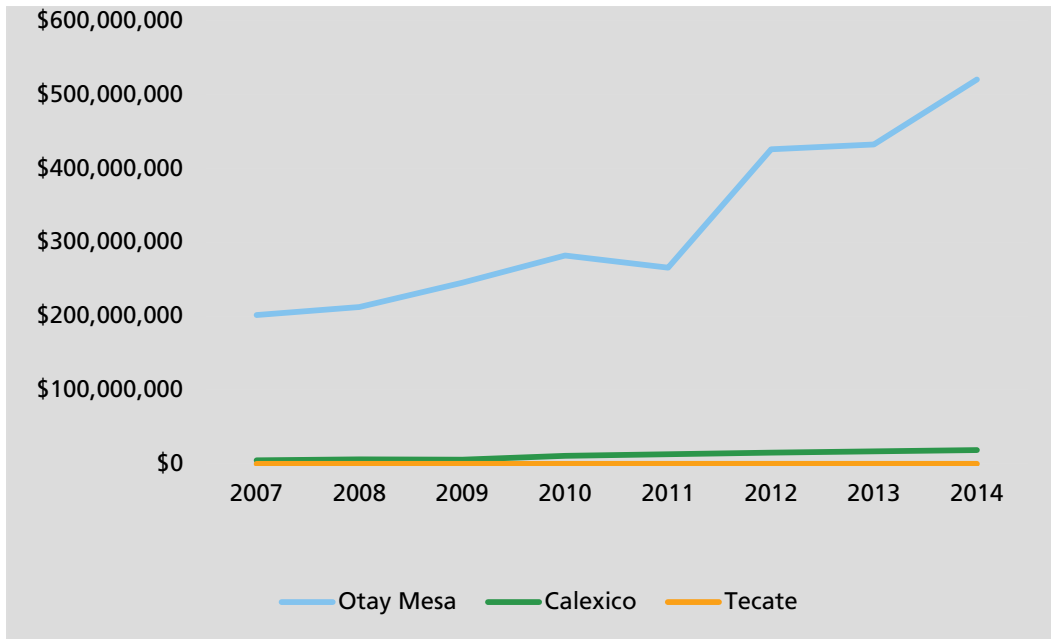

Source: Transborder Freight
Bananas

The Port of San Diego is the single entry point for imported bananas. The volume trends are shown in Figure E.13:

Figure E.13: 2008 - 2012 San Diego Waterborne Banana Imports by Tons

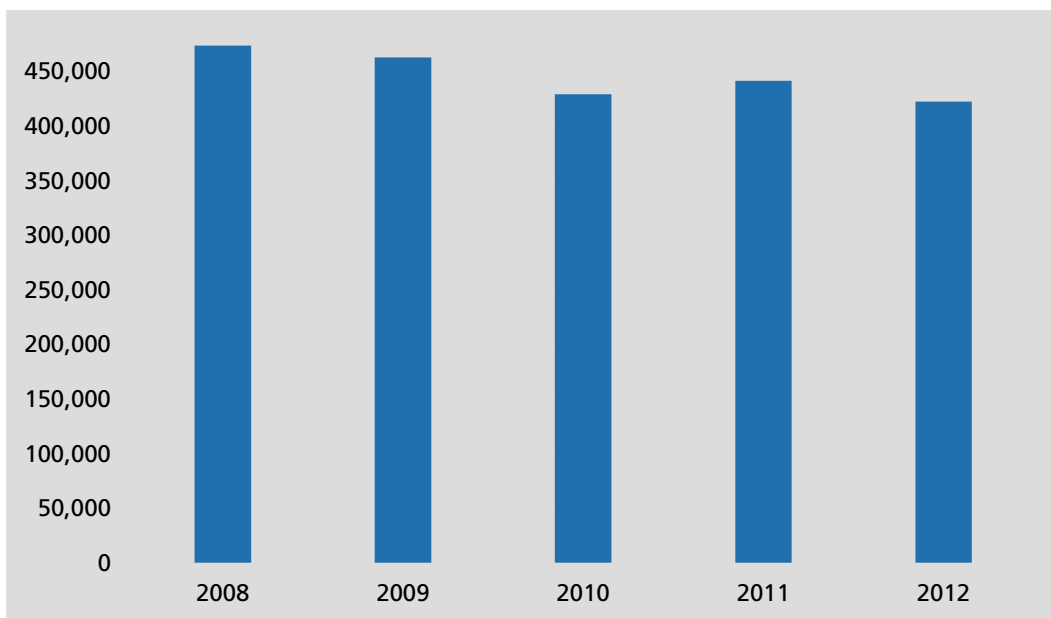

Source: U.S. Army Corps. of Engineers

Strawberries

The chart below shows the trends for imported strawberries from Mexico via San Diego.

Figure E.14: 2008 - 2013 Strawberry Imports from Mexico by Kgs.¹

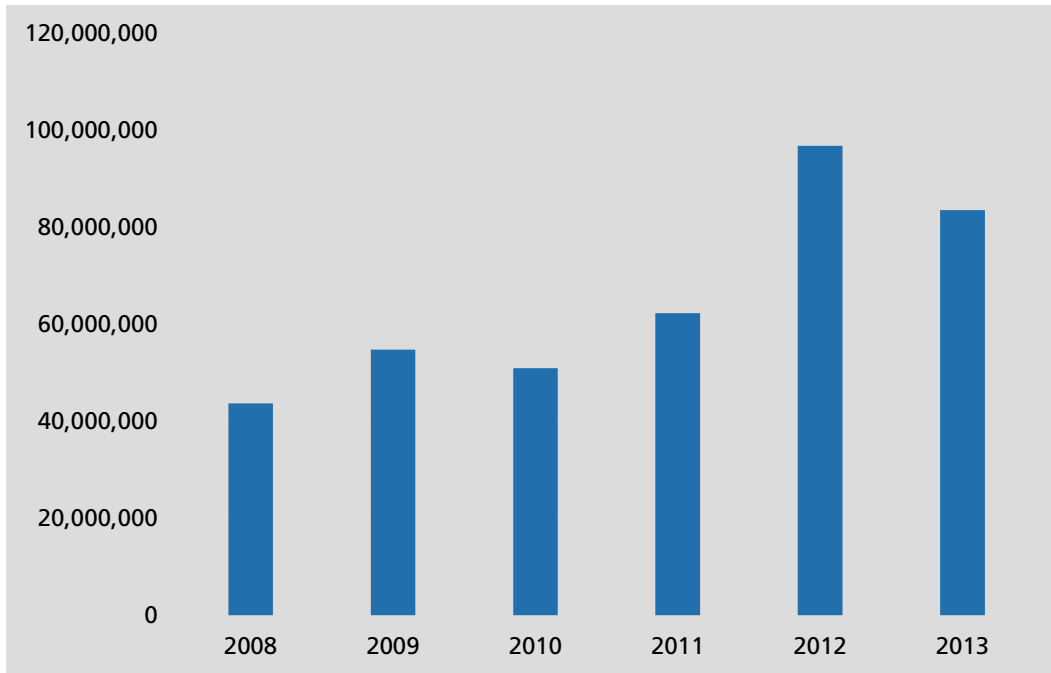

Source: U.S. Census

¹ One kilogram is equivalent to 2.20462 pounds.

Exported Meat to Mexico

The proximity of San Diego to the Baja California Cities of Tijuana and Mexicali has resulted in the area becoming a transportation corridor for export meats and a transshipment/consolidation point for these commodities. The largest percentage of meat exports through San Diego is pork and chicken.

Figure E.15: 2012 Meat Exports through Otay Mesa to Mexico

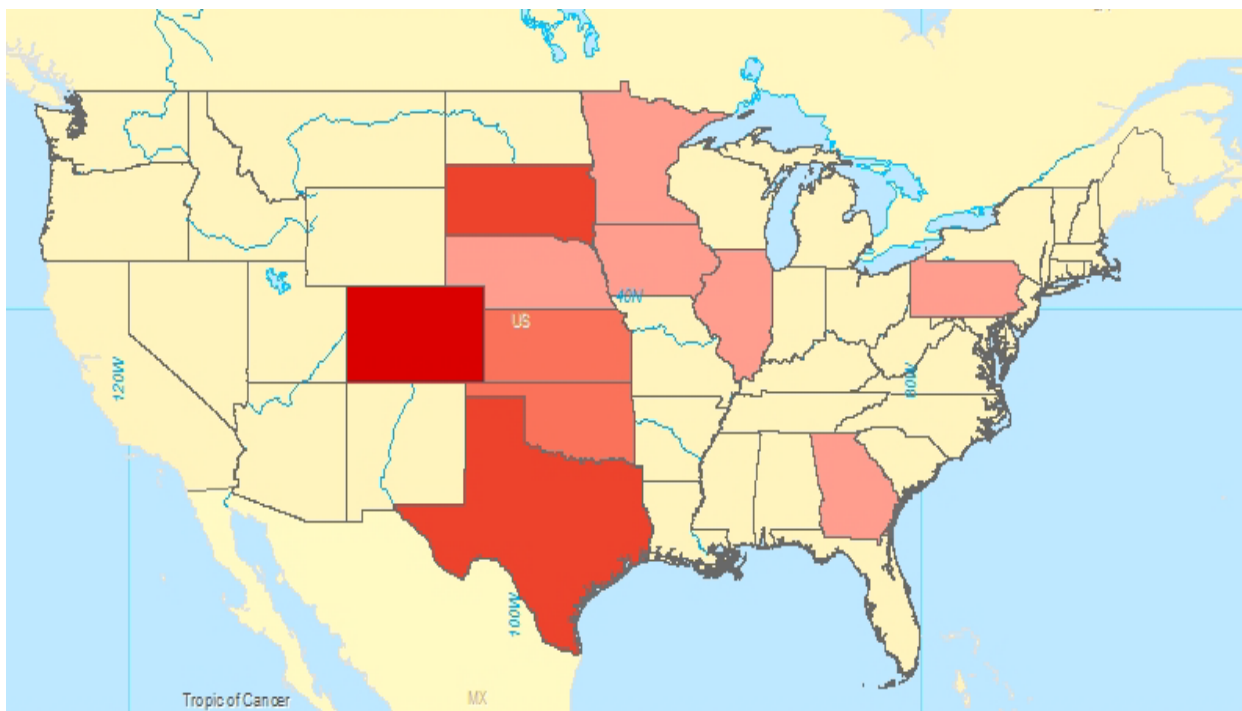

Source: FAF 3.5

Seventy-nine percent of the meat exported through San Diego originates in California. The remaining origins are highlighted in the map above. The largest destinations by volume are shown in the chart below:

Table E.2: 2012 Meat Exports through Otay Mesa to Mexico by Tons

State	2012 Ktons
Colorado	3.5795
Texas	1.2818
South Dakota	1.0962
Kansas	0.948
Oklahoma	0.6117
Nebraska	0.2743
Illinois	0.2014
Pennsylvania	0.1923
Georgia	0.1374
Iowa	0.1365

Source: FAF 3.5

All cross-border meat and poultry export from the through the San Diego Gateway Region is done by truck. The majority of the volume by value is moving through Otay Mesa, with that percentage increasing since 2012.

Figure E.16: 2007 – 2014 San Diego and Imperial Meat and Poultry Exports to Baja California by Trade Value

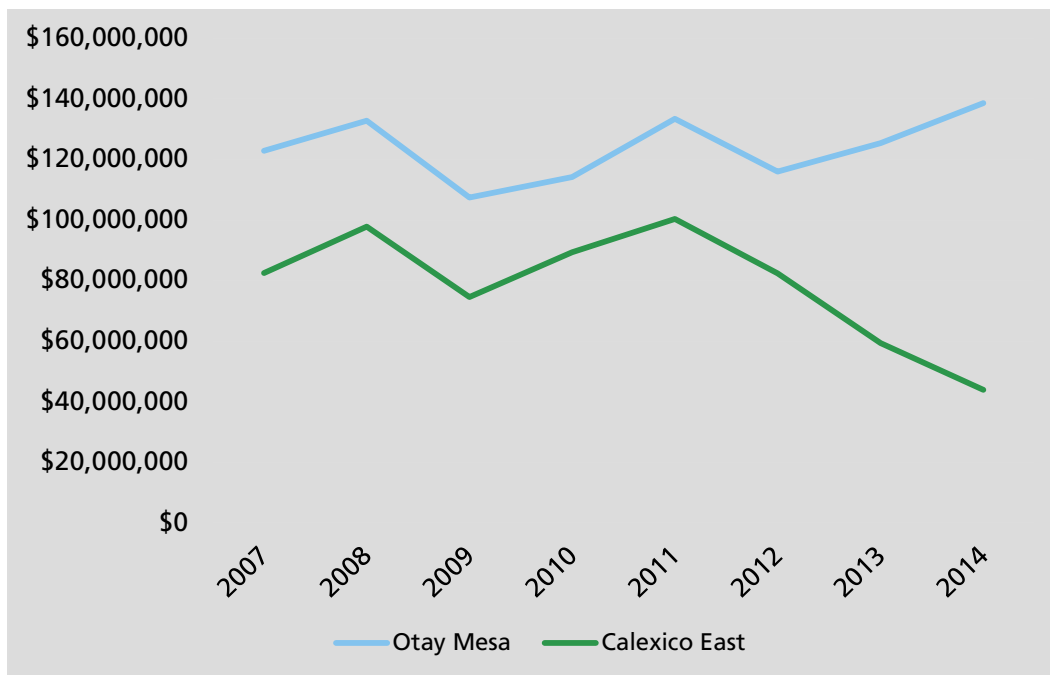

Source: Transborder Freight

Chicken

Figure E.17: 2010 – 2014 Chicken Exports to Mexico via San Diego by Kgs.²

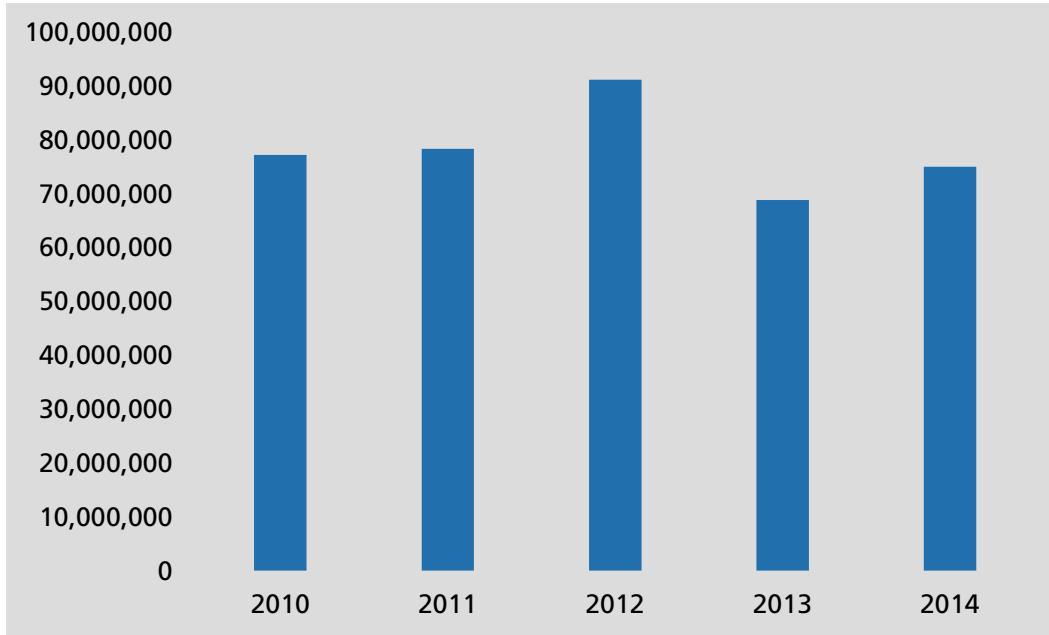

Source: U.S. Census

Pork

Figure E.18: 2010 – 2014 Pork Exports to Mexico via San Diego by Kgs.³

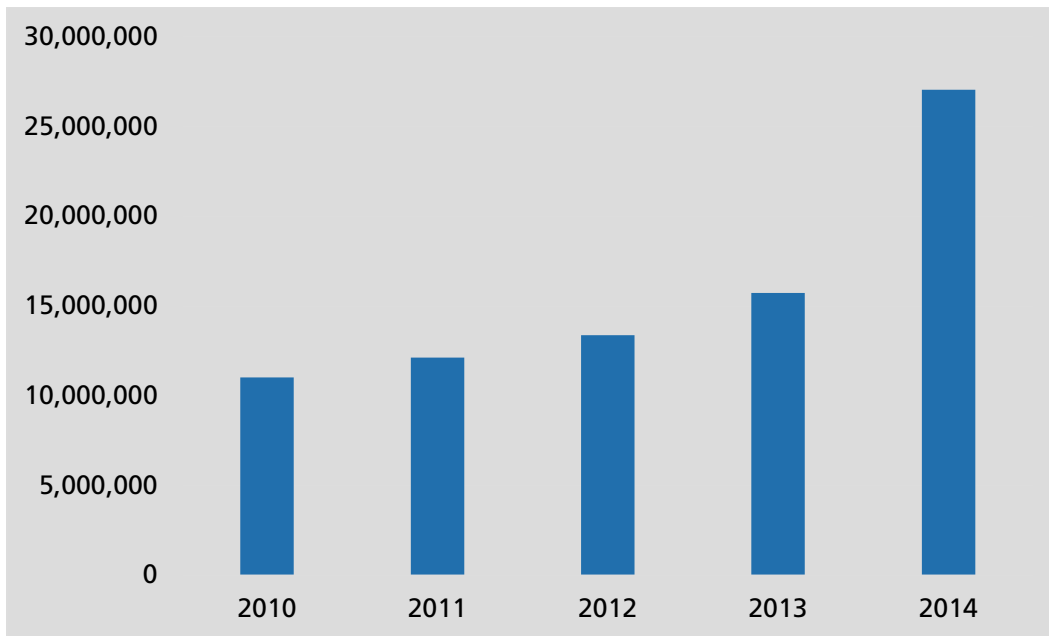

Source: U.S. Census

² One kilogram is equivalent to 2.20462 pounds.

³ Ibid.

Figure E.19: San Diego and Imperial Counties Perishables Freight Flow

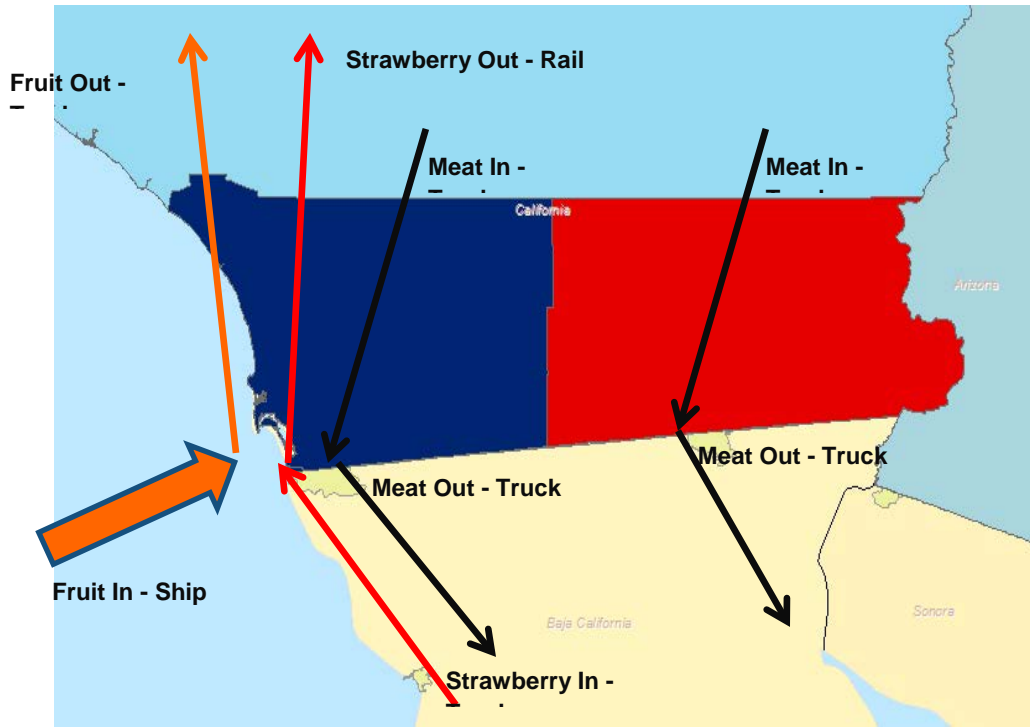

Source: SD Freight Rail Consulting

Figure E.20: San Diego Perishables Freight Flow Detail

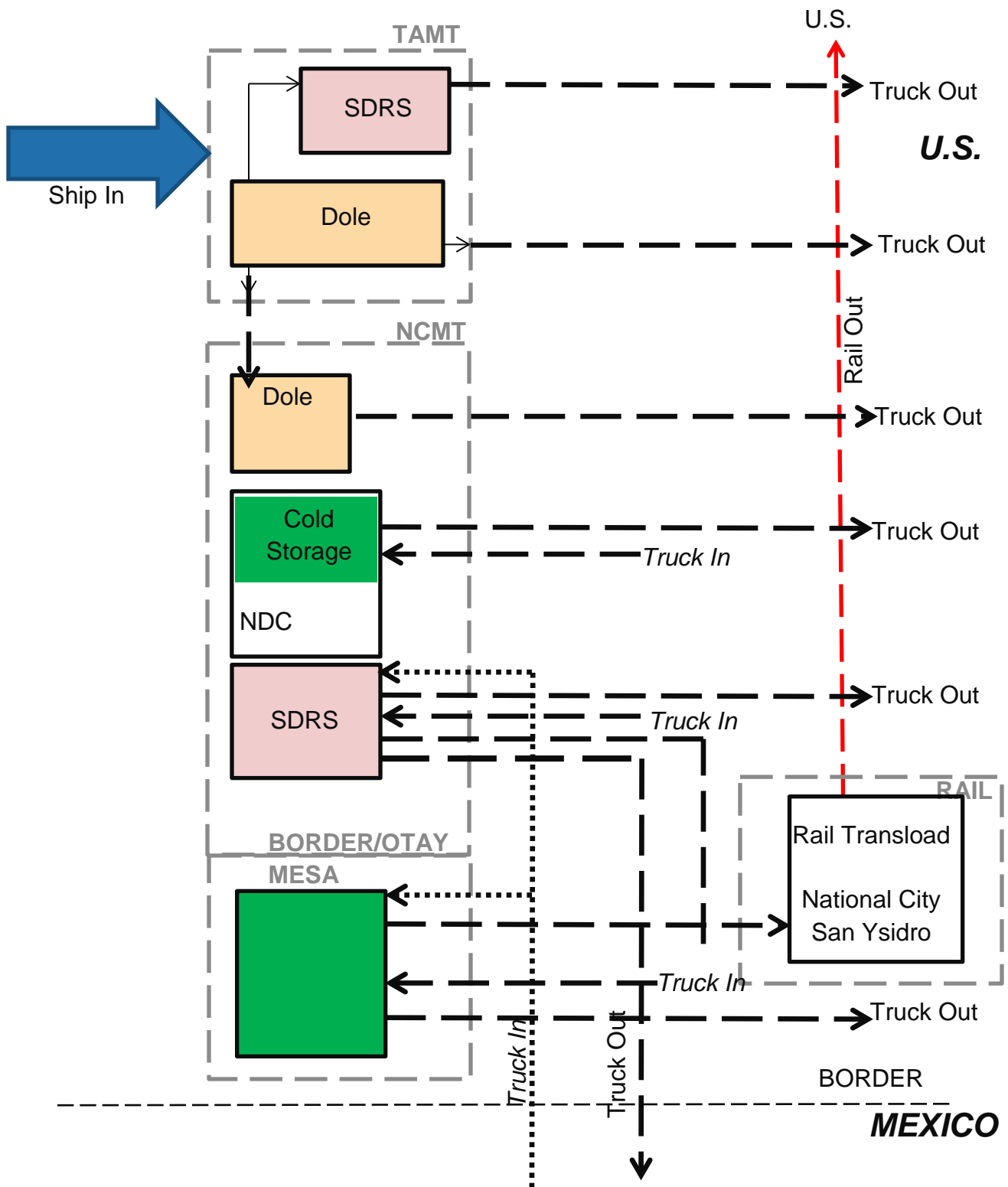

Facilities

Facilities to support the movement and distribution of meat and fruit are scattered throughout the southern portion of San Diego County. The majority of the facilities are located on or near marine terminals, or near the border.

Figure E.21: San Diego Meat and Fruit Facilities

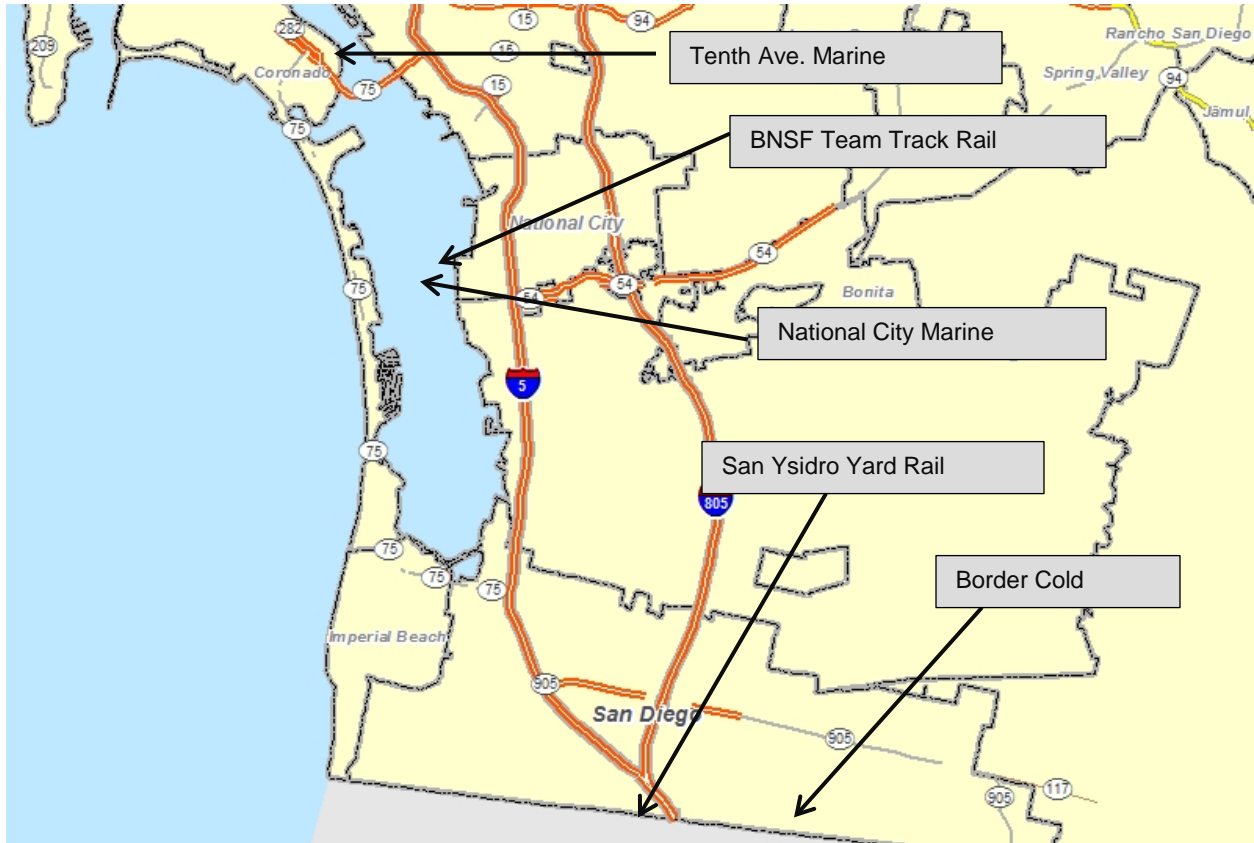

Source: SD Freight Rail Consulting

Further details on facilities in the following categories are below:

- Tenth Avenue Marine Terminal Facilities
- National City Marine Terminal Facilities
- Rail Transload Facilities
- Border Cold Storage Facilities

Figure E.22: Tenth Avenue Marine Terminal Facilities



Source: SD Freight Rail Consulting

The perishable fruit and cold storage operations take up a major portion of the TAMT footprint. TAMT is a unique niche market port. Recently it has become one of the premier West Coast refrigerated facilities.

Originally the major banana producers and marketers were located at the major distribution hub of Los Angeles/Long Beach. But as those major Ports expanded their container operations, the smaller niche markets including bananas and other bulk products began to get squeezed out of terminal facilities. To protect their distribution franchises, the major marketers began moving to smaller niche Ports to provide longer term security. The first move on the West Coast was Del Monte which moved to Port Hueneme. Dole moved from Los Angeles to San Diego in 2002. Chiquita relocated from Long Beach to Hueneme in 2004. All three producers now have long term commitment with their respective Ports. San Diego is the second largest of the West Coast refrigerated facility ports.

Dole is the largest producer of bananas and pineapples in the world. They have three gateways into the United States to serve the American market. San Diego serves the Western U.S. market.

Harborside Refrigerated Services occupies the cold storage facility on TAMT. The facility has over 200,000 sq. ft. of refrigerated space and 11 individual storage rooms.

The blue shaded areas above show the properties leased for container parking and cold storage. Specific locations of individual facilities are shown on the following page.

Figure E.23: Tenth Avenue Marine Terminal Process

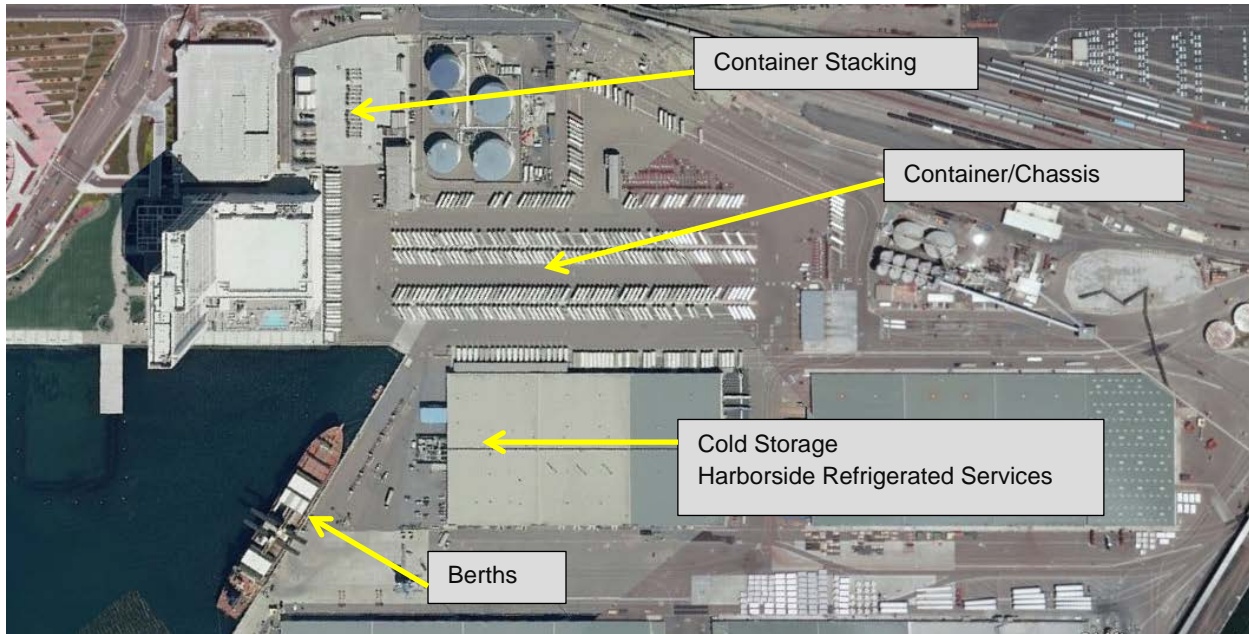

Source: SD Freight Rail Consulting

Figure E.24: Tenth Avenue Marine Terminal Operations



M/V Dole California unloading at TAMT



Trailer/Chassis Storage Area



Vessel at TAMT Berths 10-1/10-2

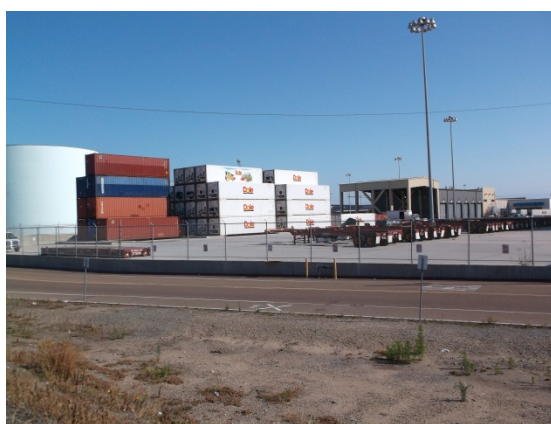

Container Stacking Area

Source: SD Freight Rail Consulting

National City Marine Terminal Facilities

A Dole container parking yard and two cold storage facilities are located on the property owned by the Port of San Diego within National City.

Figure E.25: National City Marine Terminal Facilities



Source: SD Freight Rail Consulting

The blue shaded areas above show the properties leased for container parking and cold storage.

Specific locations of individual facilities are shown on the following page.

Figure E.26: National City Marine Terminal Process



Source: SD Freight Rail Consulting

Figure E.27: National City Marine Terminal Operations



Container Parking



Harvest Meat



Truck Shuttle



San Diego Refrigerated

Source: SD Freight Rail Consulting

Rail Transload Facilities

Figure E.28: Rail Transload Facility Locations

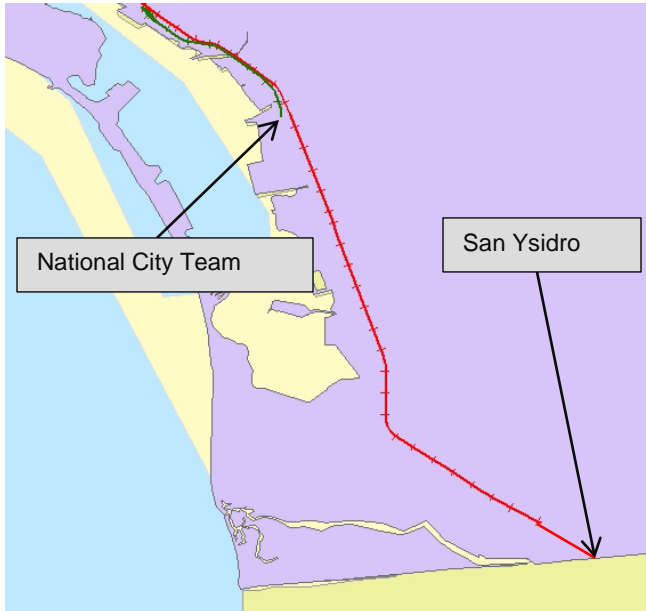

The rail facilities include two transloading facilities:

- National City Team Track – serves the NCMT cold storage facilities; two refrigerated car spots; operated by BNSF Railway
- San Ysidro Yard – serves the border/Otay Mesa cold storage facilities; two refrigerated car spots; operated by the San Diego & Imperial Valley Railroad (SDIV)

Source: SD Freight Rail Consulting

Figure E.29: National City Team Track



Source: SD Freight Rail Consulting

Figure E.30: San Ysidro Yard



Source: SD Freight Rail Consulting

Border Cold Storage Facilities

San Diego serves as a gateway for fresh and frozen foods to and from Baja California Mexico.

This requires specialized cold storage facilities. Meat, fruit, and vegetables have differing shipping characteristics including temperature and humidity. Therefore, commodities can be mixed only with others that have the same environmental requirements.

There are cold storage facilities located on the border to serve the crossborder meet and fruit market. One of the larger participants is Innovative Cold Storage Enterprises in Otay Mesa.

Innovative Cold Storage Enterprises has two facilities located on the border. Services include cross docking, refrigerated and frozen cold storage including a blast freezer, and inspections. ICE 1 is the original facility with 3,700,000 sq. ft. of cold storage. Demand for cold storage space led to an expansion with a new energy efficient building that provided an additional 7,500,000 sq. ft. of cold storage.

Figure E.31: Locations in Otay Mesa



Source: SD Freight Rail Consulting

Figure E.32: ICE 1 and 2

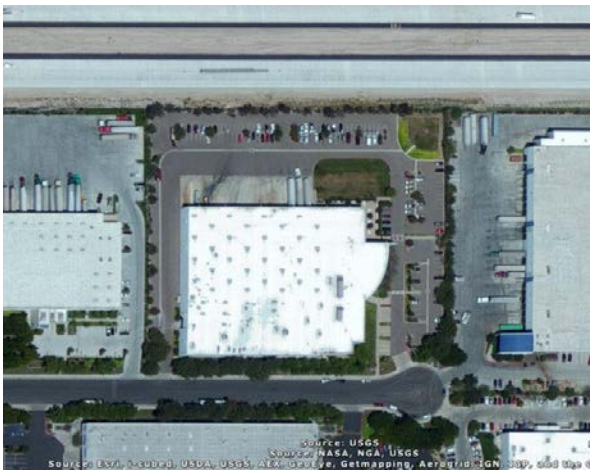

ICE 1



ICE 2

Source: SD Freight Rail Consulting

San Diego Refrigerated which operates the facility at NCMT also has a cold storage facility in Otay Mesa. There are also other refrigerated facilities around the border crossing.

Equipment

Figure E.33: Vessels



Dole California



Dole California

Source: SD Freight Rail Consulting

The Dole vessels serving San Diego are geared (have their own cranes) and can carry 491 40-foot refrigerated containers.

Dole provides weekly service to San Diego from the following Central and South American ports:

- Guayaquil, Ecuador
- Paita, Peru
- Caldera, Costa Rica
- Quetzal, Honduras

The ships were built between 1989 and 1991, and have a service speed of 20 knots. As of 2014, the service was provided by three vessels: Dole California, Dole Ecuador, and Dole Costa Rica.

New ships have been ordered to modernize the fleet with more fuel efficient vessels and provide more capacity to accommodate the growing market. The new ships will have a capacity of 771 40-foot refrigerated containers.

Figure E.34: Refrigerated Containers



Container on Chassis



Container on Vessel

Source: SD Freight Rail Consulting

Shipment of vessels is primarily done using a 40-foot refrigerated container. Each container has an integral refrigerated unit. When on board ship, the container is powered by electrical connectors. When on a truck chassis, a generator located on the underside of the chassis provides the electrical power. When on the port, the reefer units are plugged into electrical outlets as an environmental mitigation measure.

Figure E.35: Refrigerated Trailers



53' Refrigerated Trailer



Tractor and 53' Refrigerated Trailer

Source: SD Freight Rail Consulting

The standard truck trailer for the perishable market is a 53' trailer with a truck refrigeration unit (TRU) attached to the forward end of the trailer. These units are diesel powered with fuel tank located on the underside of the trailer.

Figure E.36: Refrigerated Rail Cars



64' Railcar



72' Railcar

Source: SD Freight Rail Consulting

Refrigerated rail cars vary in size with most being in the 64' range. The weight of the product determines the size of the rail car which can be used. Heavier commodities use the 64' while lighter produce would use the 73' cars. The cars are usually loaded by fork lift which enters the car through a plug door on the side.